

CURRENT OWNER		TOPO	UTILITIES	STRT / ROAD	LOCATION	CURRENT ASSESSMENT							
RICHTER, MEREDITH						Description	Code	Assessed	Assessed	801 FY2024 BARNSTABLE, MA			
720 PITCHERS WAY UNIT A-12						RESIDNTL	1020	239,700	239,700				
HYANNIS MA 02601													
SUPPLEMENTAL DATA													
Alt Prcl ID Split Zonin BID Parcel ResExpt Q #DL 1 UNIT 12 #DL 2 BLDG A GIS ID F_981842_2703782				Plan Ref. 447/55-56 Land Ct# #SR Life Estate PP STATU Assoc Pid#		Total		239,700	239,700	VISION			
RECORD OF OWNERSHIP		BK-VOL/PAGE	SALE DATE	Q/U	V/I	SALE PRICE	VC	PREVIOUS ASSESSMENTS (HISTORY)					
RICHTER, MEREDITH		35580 306	01-06-2023	Q	I	260,000	00	Year	Code	Assessed	Year	Code	Assessed
CHRISTENSEN, CAROL L		35432 207	10-19-2022	U	I	1	1F	2023	1020	228,800	2022	1020	174,900
CHRISTENSEN, CAROL L & CHENEY, AIMEE		35436 128	01-10-2020	U	I	1	1F				2021	1020	150,700
CHRISTENSEN, ROBERT L & CAROL L & KINNEAR, PATRICIA E		28861 0154 10604 0246	05-12-2015 02-10-1997	Q Q	I I	130,000 55,000	00 00					1020	3,100
		Total				228,800		Total		174,900	Total		153,800

EXEMPTIONS		OTHER ASSESSMENTS					PREVIOUS ASSESSMENTS (HISTORY)							
Year	Code	Description	Amount	Code	Description	Number	Amount	Comm Int	Year	Code	Assessed	Year	Code	Assessed
			0.00											
Total		0.00								228,800		174,900		153,800

ASSESSING NEIGHBORHOOD		NOTES	
Nbhd	Nbhd Name	B	Tracing
0001			HYAN

BUILDING PERMIT RECORD		VISIT / CHANGE HISTORY												
Permit Id	Issue Date	Type	Description	Amount	Insp Date	% Comp	Date Comp	Comments	Date	Id	Type	Is	Cd	Purpost/Result
									11-15-2021	BM	22		22	Change of Address
									04-23-2020	WD			FR	Field Review
									11-18-2019	CK	22		22	Change of Address
									12-11-2018	SR	02		03	Cycl Insp Comp
									09-16-2013	TP	03		16	In Office Review

LAND LINE VALUATION SECTION																		
B	Use Code	Description	Zone	Dist	Land Type	Land Units	Unit Price	Size Adj	Site Index	Cond.	Nbhd.	Nbhd. Adj	Notes	Location Adjustmen	Adj Unit P	Land Value		
1	102U	Condominium M	RB	4		0 SF	0.00	1.00000	5	1.00	0001	1.000		0.0000	0	0		
Total Card Land Units						0 SF	Parcel Total Land Area						0.00	Total Land Value				0

CONSTRUCTION DETAIL			CONSTRUCTION DETAIL (CONTINUED)		
Element	Cd	Description	Element	Cd	Description
Style	55	Condominium			
Model	05	Res Condo			
Bedrm Func	C	Average			
Stories	1	1 Story			
Occupancy	0				
Interior Wall 1	05	Drywall			
Interior Wall 2					
Interior Floor 1	14	Carpet			
Interior Floor 2					
Heat Fuel	04	Electric			
Heat Type	07	Elec Baseboard			
AC Type	01	None			
Bedrooms	02	2 Bedrooms			
Full Baths	1	1 Full			
Half Baths	0				
Extra Fixtures					
Total Rooms	4	4 Rooms			
Bath Style					
Kitchen Style					
Master Deed L	1029	1 Full-0 Half			
Bath Split	10	Mixed			
Foundation	08				
AC Type Alt					
Sewer Occupan					
CONDO DATA					
Parcel Id	104288	C 0760	Owne	1.6	
	SEA MEADOW VIL	B 1	S 1		
Adjust Type	Code	Description	Factor%		
Condo Flr	1FU	FIRST FLOOR	100		
Condo Unit	MKT0	MKT0	100		
COST / MARKET VALUATION					
Building Value New		258,739			
Year Built		1988			
Effective Year Built		2003			
Depreciation Code		A			
Remodel Rating					
Year Remodeled		12			
Depreciation %		0			
Functional Obsol		0			
External Obsol		0			
Trend Factor		1			
Condition					
Condition %		88			
Percent Good		227,700			
Cns Sect Rcnld					
Dep % Ovr					
Dep Ovr Comment					
Misc Imp Ovr					
Misc Imp Ovr Comment					
Cost to Cure Ovr					
Cost to Cure Ovr Comment					

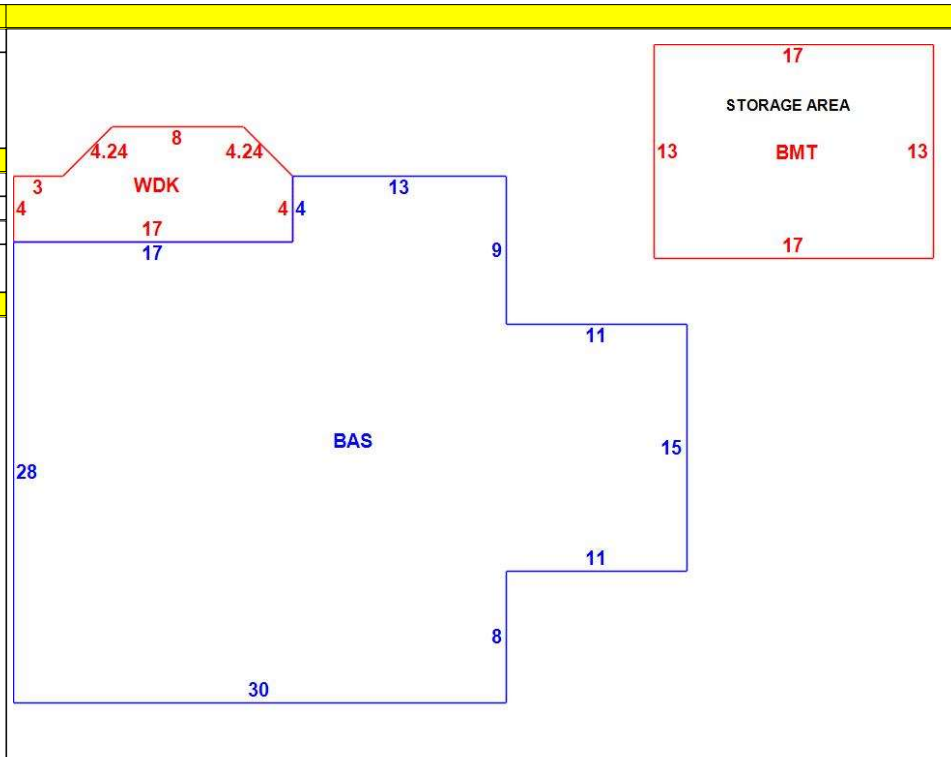

OB - OUTBUILDING & YARD ITEMS(L) / XF - BUILDING EXTRA FEATURES(B)										
Code	Description	L/B	Units	Unit Price	Yr Blt	Cond. Cd	% Gd	Grade	Grade Adj.	Appr. Value
BMT	Basement-Unfi	B	221	26.01	2005		88		0.00	8,900
WDC	Wood Deck w/	L	101	18.00	2018		98		0.00	3,100

BUILDING SUB-AREA SUMMARY SECTION						
Code	Description	Living Area	Floor Area	Eff Area	Unit Cost	Undeprec Value
BAS	First Floor	1,057	1,057	1,057	244.79	258,739
BMT	Basement Area	0	221	0	0.00	0
WDC	Wood Deck	0	101	0	0.00	0
Ttl Gross Liv / Lease Area		1,057	1,379	1,057		258,739

