

CURRENT OWNER		TOPO	UTILITIES	STRT / ROAD	LOCATION	CURRENT ASSESSMENT				
HALVERSON, SHAN FULMER TR SHAN FULMER HALVERSON TRUST 919 WILLOW SPRINGS LN  GLENDORA CA 91741						Description	Code	Assessed	Assessed	801  FY2024 BARNSTABLE, MA  <h1 style="text-align: center;">VISION</h1>
						RESIDNTL	1020	318,400	318,400	
SUPPLEMENTAL DATA						Total		318,400	318,400	
Alt Prcl ID Split Zonin BID Parcel ResExpt Q #DL 1 #DL 2 GIS ID				UNIT 17 BLDG B F_981842_2703782		Plan Ref. 447/55,57 Land Ct# #SR Life Estate PP STATU Assoc Pid#				

RECORD OF OWNERSHIP		BK-VOL/PAGE	SALE DATE	Q/U	V/I	SALE PRICE	VC	PREVIOUS ASSESSMENTS (HISTORY)									
HALVERSON, SHAN FULMER TR		28193	0232	06-10-2014	Q	I	170,000	00	Year	Code	Assessed	Year	Code	Assessed			
TERKELSEN, MARY L		11392	0260	04-30-1998	Q	I	85,000	00	2023	1020	304,600	2022	1020	235,800			
VIOLA, ANTHONY M		6307	0004	06-15-1988	Q	I	112,000	U				2021	1020	205,200			
SEA MEADOW VILLAGE ASSOC		6232	0003	04-15-1988	U	I	1	B					1020	3,700			
Total									Total		304,600	Total		235,800	Total		208,900

EXEMPTIONS			OTHER ASSESSMENTS					
Year	Code	Description	Amount	Code	Description	Number	Amount	Comm Int
Total		0.00						

ASSESSING NEIGHBORHOOD			
Nbhd	Nbhd Name	B	Tracing
0001			Batch HYAN

NOTES	
This signature acknowledges a visit by a Data Collector or Assessor	
APPRAISED VALUE SUMMARY	
Appraised Bldg. Value (Card)	290,300
Appraised Xf (B) Value (Bldg)	24,400
Appraised Ob (B) Value (Bldg)	3,700
Appraised Land Value (Bldg)	0
Special Land Value	0
Total Appraised Parcel Value	318,400
Valuation Method	C
Total Appraised Parcel Value	318,400

BUILDING PERMIT RECORD						VISIT / CHANGE HISTORY								
Permit Id	Issue Date	Type	Description	Amount	Insp Date	% Comp	Date Comp	Comments	Date	Id	Type	Is	Cd	Purpost/Result
									04-23-2020	WD			FR	Field Review
									12-11-2018	SR	02		03	Cycl Insp Comp
									09-16-2013	TP	03		16	In Office Review

LAND LINE VALUATION SECTION																		
B	Use Code	Description	Zone	Dist	Land Type	Land Units	Unit Price	Size Adj	Site Index	Cond.	Nbhd.	Nbhd. Adj	Notes	Location Adjustmen	Adj Unit P	Land Value		
1	102U	Condominium M	RB	4		0 SF	0.00	1.00000	5	1.00	0001	1.000		0.0000	0	0		
Total Card Land Units						0 SF	Parcel Total Land Area						0.00	Total Land Value				0

CONSTRUCTION DETAIL			CONSTRUCTION DETAIL (CONTINUED)		
Element	Cd	Description	Element	Cd	Description
Style	55	Condominium			
Model	05	Res Condo			
Bedrm Func	C	Average			
Stories	2	2 Stories			
Occupancy	0				
Interior Wall 1	05	Drywall			
Interior Wall 2					
Interior Floor 1	14	Carpet			
Interior Floor 2					
Heat Fuel	04	Electric			
Heat Type	07	Elec Baseboard			
AC Type	01	None			
Bedrooms	03	3 Bedrooms			
Full Baths	2	2 Full			
Half Baths	0				
Extra Fixtures					
Total Rooms	5	5 Rooms			
Bath Style					
Kitchen Style					
Master Deed L	1389				
Bath Split	20	2 Full-0 Half			
Foundation	01	Poured Conc.			
AC Type Alt					
Sewer Occupan					
<b>CONDO DATA</b>					
Parcel Id	104288	C 0760	Owne	2.3	
	SEA MEADOW VIL	B 1	S 1		
Adjust Type	Code	Description	Factor%		
Condo Flr	MFE	MULTI FL END	100		
Condo Unit	MKT0	MKT0	100		
<b>COST / MARKET VALUATION</b>					
Building Value New		329,927			
Year Built		1988			
Effective Year Built		2003			
Depreciation Code		A			
Remodel Rating					
Year Remodeled		12			
Depreciation %		0			
Functional Obsol		0			
External Obsol		0			
Trend Factor		1			
Condition					
Condition %		88			
Percent Good		88			
Cns Sect Rcnd		290,300			
Dep % Ovr					
Dep Ovr Comment					
Misc Imp Ovr					
Misc Imp Ovr Comment					
Cost to Cure Ovr					
Cost to Cure Ovr Comment					

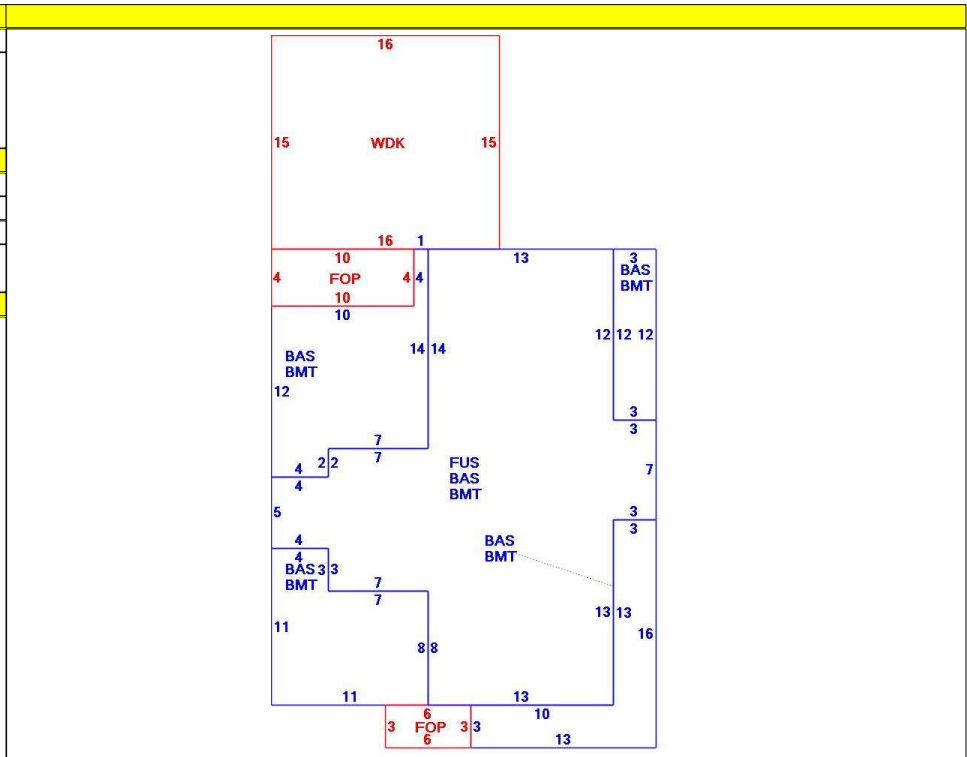

**OB - OUTBUILDING & YARD ITEMS(L) / XF - BUILDING EXTRA FEATURES(B)**

Code	Description	L/B	Units	Unit Price	Yr Blt	Cond. Cd	% Gd	Grade	Grade Adj.	Appr. Value
BMT	Basement-Unfi	B	863	26.01	2005		88		0.00	21,100
FOP	Open Porch-ro	B	58	55.00	2005		88		0.00	3,300
WDC	Wood Decking	L	240	20.00	2004		70		0.00	3,700

**BUILDING SUB-AREA SUMMARY SECTION**

Code	Description	Living Area	Floor Area	Eff Area	Unit Cost	Undeprec Value
BAS	First Floor	863	863	863	237.36	204,840
BMT	Basement Area	0	863	0	0.00	0
FOP	Open Porch	0	58	0	0.00	0
FUS	Upper Story	527	527	527	237.36	125,087
WDC	Wood Deck	0	240	0	0.00	0
Ttl Gross Liv / Lease Area		1,390	2,551	1,390		329,927

