

CONSTRUCTION DETAIL			CONSTRUCTION DETAIL (CONTINUED)		
Element	Cd	Description	Element	Cd	Description
Style	55	Condominium			
Model	05	Res Condo			
Bedrm Func	C	Average			
Stories	1	1 Story			
Occupancy	0				
Interior Wall 1	05	Drywall			
Interior Wall 2					
Interior Floor 1	14	Carpet			
Interior Floor 2					
Heat Fuel	04	Electric			
Heat Type	07	Elec Baseboard			
AC Type	01	None			
Bedrooms	02	2 Bedrooms			
Full Baths	1	1 Full			
Half Baths	0				
Extra Fixtures					
Total Rooms	4	4 Rooms			
Bath Style					
Kitchen Style					
Master Deed L	1021				
Bath Split	10	1 Full-0 Half			
Foundation	08	Mixed			
AC Type Alt					
Sewer Occupan					
CONDO DATA					
Parcel Id	104288	C 0760	Owne	1.5	
	SEA MEADOW VIL	B 1	S 1		
Adjust Type	Code	Description	Factor%		
Condo Flr	1FE	FIRST FL END	100		
Condo Unit	MKT0	MKT0	100		
COST / MARKET VALUATION					
Building Value New		261,168			
Year Built		1988			
Effective Year Built		2003			
Depreciation Code		A			
Remodel Rating					
Year Remodeled		12			
Depreciation %		0			
Functional Obsol		0			
External Obsol		0			
Trend Factor		1			
Condition					
Condition %		88			
Percent Good		229,800			
Cns Sect Rcnd					
Dep % Ovr					
Dep Ovr Comment					
Misc Imp Ovr					
Misc Imp Ovr Comment					
Cost to Cure Ovr					
Cost to Cure Ovr Comment					

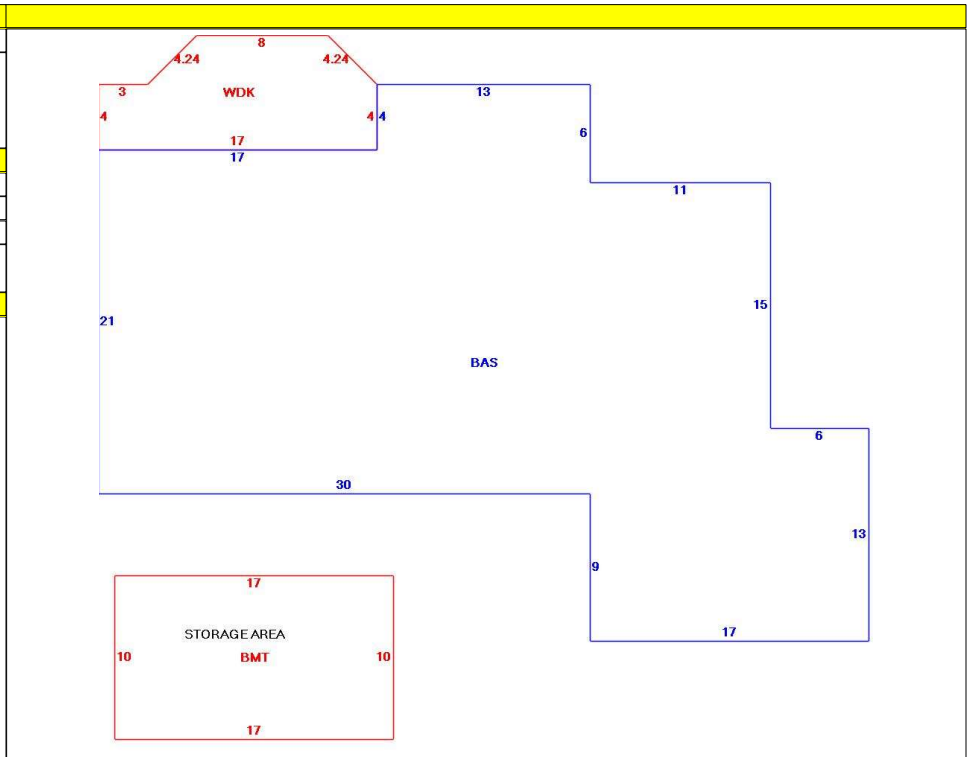

OB - OUTBUILDING & YARD ITEMS(L) / XF - BUILDING EXTRA FEATURES(B)

Code	Description	L/B	Units	Unit Price	Yr Blt	Cond. Cd	% Gd	Grade	Grade Adj.	Appr. Value
BMT	Basement-Unfi	B	170	26.01	2005		88		0.00	7,000
WDC	Wood Deck w/	L	101	18.00	2018		98		0.00	3,100

BUILDING SUB-AREA SUMMARY SECTION

Code	Description	Living Area	Floor Area	Eff Area	Unit Cost	Undeprec Value
BAS	First Floor	1,068	1,068	1,068	244.54	261,168
BMT	Basement Area	0	170	0	0.00	0
WDC	Wood Deck	0	101	0	0.00	0
Ttl Gross Liv / Lease Area		1,068	1,339	1,068		261,168

