

| CURRENT OWNER | | TOPO | UTILITIES | STRT / ROAD | LOCATION | CURRENT ASSESSMENT | | | | | | | | | | | | | | | | |
|--|------------|------------------|-------------|-------------|------------|-------------------------------|-------------|-------------------------|------------|--------------------------------------|------------|---|--|-----------|---------------------------------------|------------------|----------------|------------|------------|------|------|----------|
| BARNSTABLE HOUSING AUTHORITY 146 SOUTH STREET HYANNIS MA 02601 | | | | | | Description | | Code | Assessed | | Assessed | | 801 FY2024 BARNSTABLE, MA VISION | | | | | | | | | |
| | | | | | | EXEMPT | | 9700 | 242,500 | | 242,500 | | | | | | | | | | | |
| SUPPLEMENTAL DATA | | | | | | Alt Prcl ID | | Split Zonin | | Plan Ref. 447/55,59 | | | | | | | | | | | | |
| #DL 1 | | UNIT 41 | | Land Ct# | | #SR | | Life Estate | | PP STATU | | | | | | | | | | | | |
| #DL 2 | | BLDG F | | Assoc Pid# | | | | | | | | | | | | | | | | | | |
| GIS ID | | F_981842_2703782 | | | | | | | | | | | | | | | | | | | | |
| RECORD OF OWNERSHIP | | | | | | BK-VOL/PAGE | | SALE DATE | | Q/U | V/I | SALE PRICE | | VC | PREVIOUS ASSESSMENTS (HISTORY) | | | | | | | |
| BARNSTABLE HOUSING AUTHORITY SEA MEADOW VILLAGE ASSOC | | | | | | 6337 | 0080 | 07-15-1988 | Q | I | 95,000 | | U | Year | Code | Assessed | Year | Code | Assessed V | Year | Code | Assessed |
| | | | | | | 6232 | 0003 | 04-15-1988 | U | I | 1 | | B | 2023 | 9700 | 231,500 | 2022 | 9700 | 176,800 | 2021 | 9700 | 152,400 |
| | | | | | | Total | | | | 231,500 | | Total | 176,800 | | Total | 155,500 | | | | | | |
| EXEMPTIONS | | | | | | OTHER ASSESSMENTS | | | | | | This signature acknowledges a visit by a Data Collector or Assessor | | | | | | | | | | |
| Year | Code | Description | | Amount | | Code | Description | | Number | Amount | | Comm Int | | | | | | | | | | |
| Total | | | | | | 0.00 | | | | | | | | | | | | | | | | |
| ASSESSING NEIGHBORHOOD | | | | | | | | | | | | APPRAISED VALUE SUMMARY | | | | | | | | | | |
| Nbhd | | Nbhd Name | | B | | Tracing | | Batch | | Appraised Bldg. Value (Card) 230,600 | | | | | | | | | | | | |
| 0001 | | | | | | | | HYAN | | Appraised Xf (B) Value (Bldg) 8,800 | | | | | | | | | | | | |
| NOTES | | | | | | | | | | | | Appraised Ob (B) Value (Bldg) 3,100 | | | | | | | | | | |
| | | | | | | | | | | | | Appraised Land Value (Bldg) 0 | | | | | | | | | | |
| | | | | | | | | | | | | Special Land Value 0 | | | | | | | | | | |
| | | | | | | | | | | | | Total Appraised Parcel Value 242,500 | | | | | | | | | | |
| | | | | | | | | | | | | Valuation Method C | | | | | | | | | | |
| | | | | | | | | | | | | Total Appraised Parcel Value 242,500 | | | | | | | | | | |
| BUILDING PERMIT RECORD | | | | | | VISIT / CHANGE HISTORY | | | | | | | | | | | | | | | | |
| Permit Id | Issue Date | Type | Description | Amount | Insp Date | % Comp | Date Comp | Comments | | | | Date | Id | Type | Is | Cd | Purpost/Result | | | | | |
| 201201531 | 03-19-2012 | CM | Commercial | 1,775 | 06-30-2013 | 100 | 06-30-2013 | REPAIR SAGGING FLR W PE | | | | 05-14-2020 | GM | 04 | | FR | Field Review | | | | | |
| | | | | | | | | | | | 12-11-2018 | SR | 02 | | 03 | Cycl Insp Comp | | | | | | |
| | | | | | | | | | | | 09-16-2013 | TP | 03 | | 16 | In Office Review | | | | | | |
| | | | | | | | | | | | 06-15-2004 | PT | 02 | | 01 | Meas/Est | | | | | | |
| LAND LINE VALUATION SECTION | | | | | | | | | | | | | | | | | | | | | | |
| B | Use Code | Description | Zone | Dist | Land Type | Land Units | Unit Price | Size Adj | Site Index | Cond. | Nbhd. | Nbhd. Adj | Notes | | Location Adjustmen | | Adj Unit P | Land Value | | | | |
| 1 | 970U | Hsng Auth M-05 | RB | 4 | | 0 SF | 0.00 | 1.00000 | 5 | 1.00 | 0001 | 1.000 | | | 0.0000 | | 0 | 0 | | | | |
| Total Card Land Units | | | | | | 0 | SF | Parcel Total Land Area | | | | | | 0.00 | Total Land Value | | | | | | 0 | |

| CONSTRUCTION DETAIL | | | CONSTRUCTION DETAIL (CONTINUED) | | |
|--------------------------------|----------------|----------------|---------------------------------|-----|-------------|
| Element | Cd | Description | Element | Cd | Description |
| Style | 55 | Condominium | | | |
| Model | 05 | Res Condo | | | |
| Bedrm Func | C | Average | | | |
| Stories | 1 | 1 Story | | | |
| Occupancy | 0 | | | | |
| Interior Wall 1 | 05 | Drywall | | | |
| Interior Wall 2 | | | | | |
| Interior Floor 1 | 14 | Carpet | | | |
| Interior Floor 2 | | | | | |
| Heat Fuel | 04 | Electric | | | |
| Heat Type | 07 | Elec Baseboard | | | |
| AC Type | 01 | None | | | |
| Bedrooms | 02 | 2 Bedrooms | | | |
| Full Baths | 1 | 1 Full | | | |
| Half Baths | 0 | | | | |
| Extra Fixtures | | | | | |
| Total Rooms | 4 | 4 Rooms | | | |
| Bath Style | | | | | |
| Kitchen Style | | | | | |
| Master Deed L | 1052 | | | | |
| Bath Split | 10 | 1 Full-0 Half | | | |
| Foundation | 08 | Mixed | | | |
| AC Type Alt | | | | | |
| Sewer Occupan | | | | | |
| CONDO DATA | | | | | |
| Parcel Id | 104288 | C 0760 | Ownr | 1.7 | |
| | SEA MEADOW VIL | B 1 | S 1 | | |
| Adjust Type | Code | Description | Factor% | | |
| Condo Flr | 1FU | FIRST FLOOR | 100 | | |
| Condo Unit | MKT0 | MKT0 | 100 | | |
| COST / MARKET VALUATION | | | | | |
| Building Value New | | 262,045 | | | |
| Year Built | | 1988 | | | |
| Effective Year Built | | 2003 | | | |
| Depreciation Code | | A | | | |
| Remodel Rating | | | | | |
| Year Remodeled | | 12 | | | |
| Depreciation % | | 0 | | | |
| Functional Obsol | | 0 | | | |
| External Obsol | | 0 | | | |
| Trend Factor | | 1 | | | |
| Condition | | | | | |
| Condition % | | 88 | | | |
| Percent Good | | 230,600 | | | |
| Cns Sect Rcnld | | | | | |
| Dep % Ovr | | | | | |
| Dep Ovr Comment | | | | | |
| Misc Imp Ovr | | | | | |
| Misc Imp Ovr Comment | | | | | |
| Cost to Cure Ovr | | | | | |
| Cost to Cure Ovr Comment | | | | | |

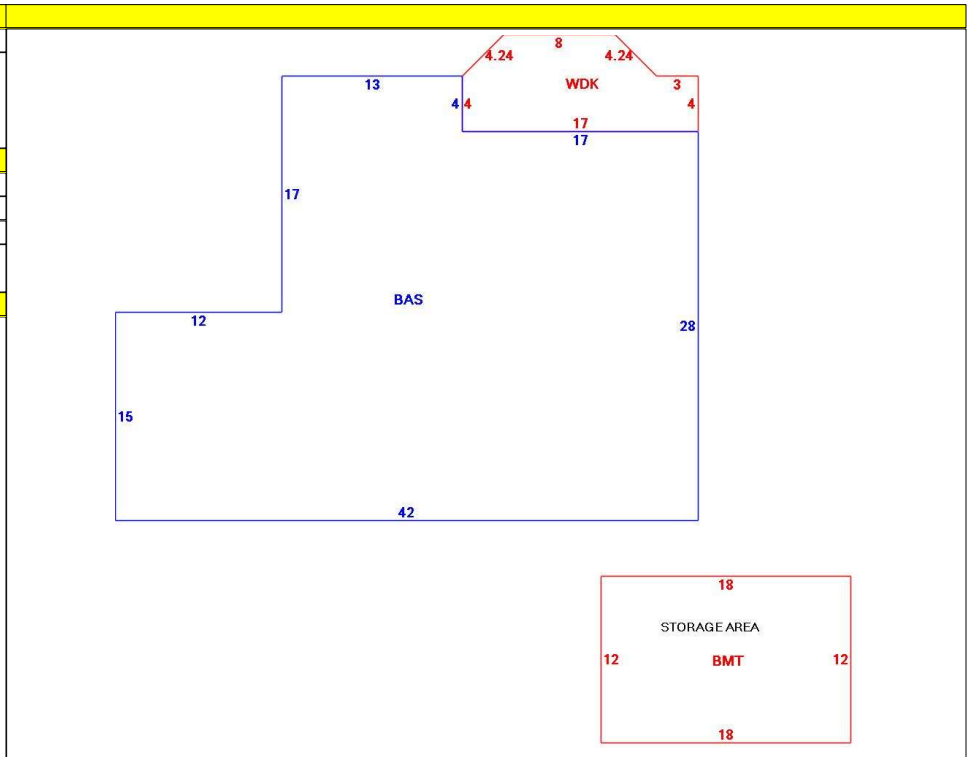

OB - OUTBUILDING & YARD ITEMS(L) / XF - BUILDING EXTRA FEATURES(B)

| Code | Description | L/B | Units | Unit Price | Yr Blt | Cond. Cd | % Gd | Grade | Grade Adj. | Appr. Value |
|------|---------------|-----|-------|------------|--------|----------|------|-------|------------|-------------|
| BMT | Basement-Unfi | B | 216 | 26.01 | 2005 | | 88 | | 0.00 | 8,800 |
| WDC | Wood Deck w/ | L | 101 | 18.00 | 2018 | | 98 | | 0.00 | 3,100 |

BUILDING SUB-AREA SUMMARY SECTION

| Code | Description | Living Area | Floor Area | Eff Area | Unit Cost | Undeprec Value |
|----------------------------|---------------|-------------|------------|----------|-----------|----------------|
| BAS | First Floor | 1,072 | 1,072 | 1,072 | 244.44 | 262,045 |
| BMT | Basement Area | 0 | 216 | 0 | 0.00 | 0 |
| WDK | Wood Deck | 0 | 101 | 0 | 0.00 | 0 |
| Ttl Gross Liv / Lease Area | | 1,072 | 1,389 | 1,072 | | 262,045 |

