

CURRENT OWNER		TOPO	UTILITIES	STRT / ROAD	LOCATION	CURRENT ASSESSMENT				
WALSH, DEBORAH & DANIEL						Description	Code	Assessed	Assessed	801 FY2024 BARNSTABLE, MA
3 BITTERSWEET LANE						RESIDNTL	1020	201,200	201,200	
BOURNE MA 02532										
SUPPLEMENTAL DATA										
Alt Prcl ID				Plan Ref. 447/55,59						
Split Zonin				Land Ct#						
BID Parcel				#SR						
ResExpt Q				Life Estate						
#DL 1				PP STATU UNFURNISHED R						
#DL 2				BLDG F						
GIS ID F_981842_2703782				Assoc Pid#						
							Total	201,200	201,200	

VISION

RECORD OF OWNERSHIP		BK-VOL/PAGE	SALE DATE	Q/U	V/I	SALE PRICE	VC	PREVIOUS ASSESSMENTS (HISTORY)									
WALSH, DEBORAH & DANIEL		26323	0024	05-11-2012	U	I	1	1A	Year	Code	Assessed	Year	Code	Assessed	Year	Code	Assessed
BIANCO, KENNETH & WALSH, DEBORAH		21838	0187	03-09-2007	U	I	1	1A	2023	1020	192,100	2022	1020	146,900	2021	1020	126,100
WALSH, DANIEL &		12277	0083	05-19-1999	U	I	1	1A									3,100
GOULD, WILLIAM & WALSH-GOULD, D		12139	0154	03-22-1999	U	I	55,000	1A									
PRATT, SHARON M		6246	0001	05-15-1988	Q	I	68,000	U									
							Total		192,100		Total		146,900		Total		129,200

EXEMPTIONS				OTHER ASSESSMENTS				This signature acknowledges a visit by a Data Collector or Assessor										
Year	Code	Description	Amount	Code	Description	Number	Amount	Comm Int										
			Total	0.00														

ASSESSING NEIGHBORHOOD				APPRAISED VALUE SUMMARY										
Nbhd	Nbhd Name	B	Tracing	Batch										
0001				HYAN										
NOTES														
										Appraised Bldg. Value (Card)	190,600			
										Appraised Xf (B) Value (Bldg)	7,500			
										Appraised Ob (B) Value (Bldg)	3,100			
										Appraised Land Value (Bldg)	0			
										Special Land Value	0			
										Total Appraised Parcel Value	201,200			
										Valuation Method	C			
										Total Appraised Parcel Value	201,200			

BUILDING PERMIT RECORD										VISIT / CHANGE HISTORY					
Permit Id	Issue Date	Type	Description	Amount	Insp Date	% Comp	Date Comp	Comments		Date	Id	Type	Is	Cd	Purpost/Result
										04-23-2020	WD			FR	Field Review
										12-11-2018	SR	02		03	Cycl Insp Comp
										09-16-2013	TP	03		16	In Office Review

LAND LINE VALUATION SECTION																		
B	Use Code	Description	Zone	Dist	Land Type	Land Units	Unit Price	Size Adj	Site Index	Cond.	Nbhd.	Nbhd. Adj	Notes	Location Adjustmen	Adj Unit P	Land Value		
1	102U	Condominium M	RB	4		0 SF	0.00	1.00000	5	1.00	0001	1.000		0.0000	0	0		
Total Card Land Units						0	SF	Parcel Total Land Area						0.00	Total Land Value			0

CONSTRUCTION DETAIL			CONSTRUCTION DETAIL (CONTINUED)		
Element	Cd	Description	Element	Cd	Description
Style	55	Condominium			
Model	05	Res Condo			
Bedrm Func	C	Average			
Stories	1	1 Story			
Occupancy	0				
Interior Wall 1	05	Drywall			
Interior Wall 2					
Interior Floor 1	14	Carpet			
Interior Floor 2					
Heat Fuel	04	Electric			
Heat Type	07	Elec Baseboard			
AC Type	01	None			
Bedrooms	01	1 Bedroom			
Full Baths	1	1 Full			
Half Baths	0				
Extra Fixtures					
Total Rooms	3	3 Rooms			
Bath Style					
Kitchen Style					
Master Deed L	866				
Bath Split	10	1 Full-0 Half			
Foundation	08	Mixed			
AC Type Alt					
Sewer Occupan					
CONDO DATA					
Parcel Id	104288	C 0760	Ownr	1.2	
	SEA MEADOW VIL	B 1	S 1		
Adjust Type	Code	Description	Factor%		
Condo Flr	1FU	FIRST FLOOR	100		
Condo Unit	MKT0	MKT0	100		
COST / MARKET VALUATION					
Building Value New		216,550			
Year Built		1988			
Effective Year Built		2003			
Depreciation Code		A			
Remodel Rating					
Year Remodeled		12			
Depreciation %		0			
Functional Obsol		0			
External Obsol		0			
Trend Factor		1			
Condition					
Condition %		88			
Percent Good		190,600			
Cns Sect Rcnld					
Dep % Ovr					
Dep Ovr Comment					
Misc Imp Ovr					
Misc Imp Ovr Comment					
Cost to Cure Ovr					
Cost to Cure Ovr Comment					

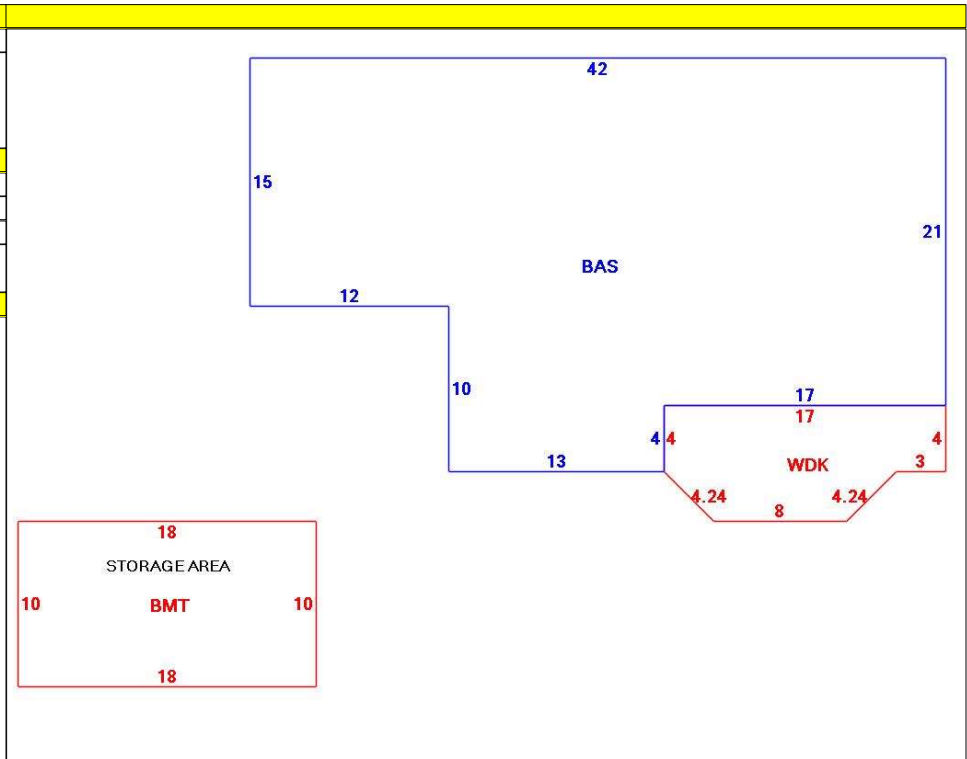

OB - OUTBUILDING & YARD ITEMS(L) / XF - BUILDING EXTRA FEATURES(B)										
Code	Description	L/B	Units	Unit Price	Yr Blt	Cond. Cd	% Gd	Grade	Grade Adj.	Appr. Value
BMT	Basement-Unfi	B	180	26.01	2005		88		0.00	7,500
WDC	Wood Deck w/	L	101	18.00	2018		98		0.00	3,100

BUILDING SUB-AREA SUMMARY SECTION						
Code	Description	Living Area	Floor Area	Eff Area	Unit Cost	Undeprec Value
BAS	First Floor	862	862	862	251.22	216,550
BMT	Basement Area	0	180	0	0.00	0
WDC	Wood Deck	0	101	0	0.00	0
Ttl Gross Liv / Lease Area		862	1,143	862		216,550

