

CURRENT OWNER		TOPO	UTILITIES	STRT / ROAD	LOCATION	CURRENT ASSESSMENT															
BARNSTABLE HOUSING AUTHORITY 146 SOUTH STREET HYANNIS MA 02601						Description		Code	Assessed		Assessed		801 FY2024 BARNSTABLE, MA VISION								
						EXEMPT		9700	291,100		291,100										
SUPPLEMENTAL DATA																					
Alt Prcl ID Split Zonin BID Parcel ResExpt Q #DL 1 UNIT 46 #DL 2 BLDG F GIS ID F_981842_2703782				Plan Ref. 447/55,59 Land Ct# #SR Life Estate PP STATU Assoc Pid#																	
						Total		291,100		291,100											
RECORD OF OWNERSHIP				BK-VOL/PAGE	SALE DATE	Q/U	V/I	SALE PRICE	VC	PREVIOUS ASSESSMENTS (HISTORY)											
BARNSTABLE HOUSING AUTHORITY				6631 0100	02-15-1989	Q	I	95,000	U	Year	Code	Assessed	Year	Code	Assessed V	Year	Code	Assessed			
SEA MEADOW VILLAGE ASSOC				6232 0003	04-15-1988	U	I	1	B	2023	9700	277,900	2022	9700	212,100	2021	9700	182,800			
																		3,600			
										Total		277,900		Total		212,100		Total		186,400	
EXEMPTIONS				OTHER ASSESSMENTS				This signature acknowledges a visit by a Data Collector or Assessor													
Year	Code	Description		Amount	Code	Description	Number	Amount	Comm Int												
				Total	0.00																
ASSESSING NEIGHBORHOOD										APPRAISED VALUE SUMMARY											
Nbhd		Nbhd Name			B			Tracing			Batch			Appraised Bldg. Value (Card)					277,700		
0001								HYAN						Appraised Xf (B) Value (Bldg)					9,800		
										Appraised Ob (B) Value (Bldg)					3,600						
										Appraised Land Value (Bldg)					0						
										Special Land Value					0						
										Total Appraised Parcel Value					291,100						
										Valuation Method					C						
										Total Appraised Parcel Value					291,100						
BUILDING PERMIT RECORD										VISIT / CHANGE HISTORY											
Permit Id	Issue Date	Type	Description	Amount	Insp Date	% Comp	Date Comp	Comments			Date	Id	Type	Is	Cd	Purpost/Result					
										05-14-2020	GM	04		FR	Field Review						
										12-11-2018	SR	02		03	Cycl Insp Comp						
										09-16-2013	TP	03		16	In Office Review						
										06-15-2004	PT	02		01	Meas/Est						
LAND LINE VALUATION SECTION																					
B	Use Code	Description	Zone	Dist	Land Type	Land Units	Unit Price	Size Adj	Site Index	Cond.	Nbhd.	Nbhd. Adj	Notes			Location Adjustmen	Adj Unit P	Land Value			
1	970U	Hsng Auth M-05	RB	4		0 SF	0.00	1.00000	5	1.00	0001	1.000				0.0000	0	0			
Total Card Land Units						0	SF	Parcel Total Land Area						0.00	Total Land Value						0

CONSTRUCTION DETAIL			CONSTRUCTION DETAIL (CONTINUED)		
Element	Cd	Description	Element	Cd	Description
Style	55	Condominium			
Model	05	Res Condo			
Bedrm Func	C	Average			
Stories	2	2 Stories			
Occupancy	0				
Interior Wall 1	05	Drywall			
Interior Wall 2					
Interior Floor 1	14	Carpet			
Interior Floor 2					
Heat Fuel	04	Electric			
Heat Type	07	Elec Baseboard			
AC Type	01	None			
Bedrooms	02	2 Bedrooms			
Full Baths	2	2 Full			
Half Baths	0				
Extra Fixtures					
Total Rooms	4	4 Rooms			
Bath Style					
Kitchen Style					
Master Deed L	1319				
Bath Split	20	2 Full-0 Half			
Foundation	08	Mixed			
AC Type Alt					
Sewer Occupan					
CONDO DATA					
Parcel Id	104288	C 0760	Owne	1.9	
	SEA MEADOW VIL	B 1	S 1		
Adjust Type	Code	Description	Factor%		
Condo Flr	2FU	SECOND FLOOR	100		
Condo Unit	MKT0	MKT0	100		
COST / MARKET VALUATION					
Building Value New		315,595			
Year Built		1988			
Effective Year Built		2003			
Depreciation Code		A			
Remodel Rating					
Year Remodeled		12			
Depreciation %		0			
Functional Obsol		0			
External Obsol		0			
Trend Factor		1			
Condition					
Condition %		88			
Percent Good		277,700			
Cns Sect Rcnld					
Dep % Ovr					
Dep Ovr Comment					
Misc Imp Ovr					
Misc Imp Ovr Comment					
Cost to Cure Ovr					
Cost to Cure Ovr Comment					

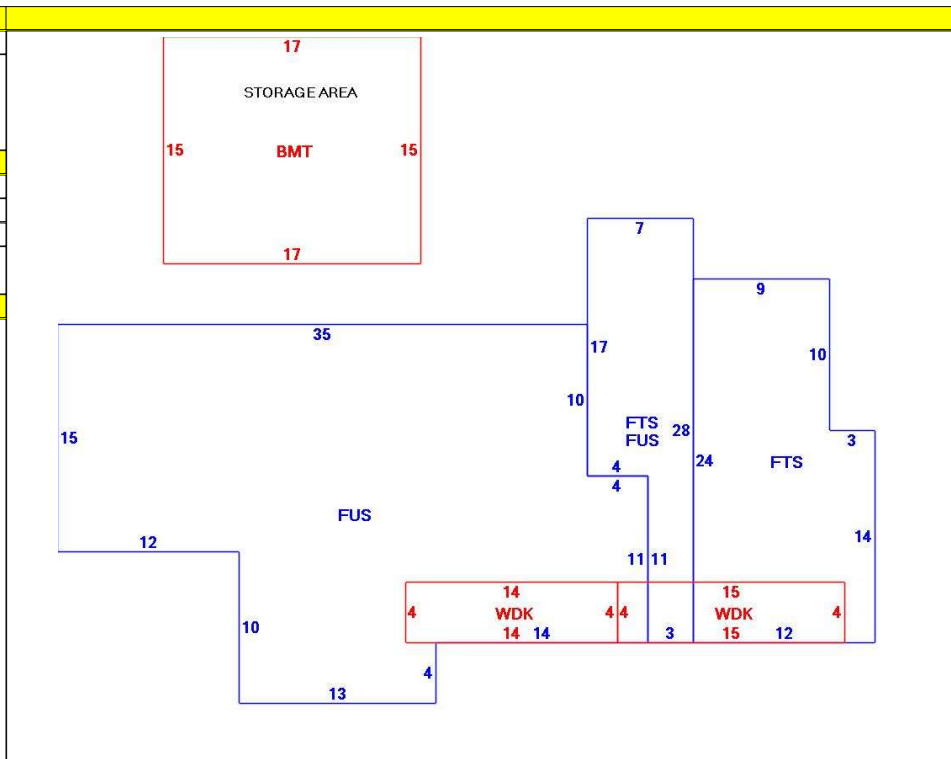

OB - OUTBUILDING & YARD ITEMS(L) / XF - BUILDING EXTRA FEATURES(B)										
Code	Description	L/B	Units	Unit Price	Yr Blt	Cond. Cd	% Gd	Grade	Grade Adj.	Appr. Value
BMT	Basement-Unfi	B	255	26.01	2005		88		0.00	9,800
WDC	Wood Decking	L	116	20.00	2018		98		0.00	3,600

BUILDING SUB-AREA SUMMARY SECTION						
Code	Description	Living Area	Floor Area	Eff Area	Unit Cost	Undeprec Value
BMT	Basement Area	0	255	0	0.00	0
FTS	Finished Third Story	410	410	410	238.91	97,951
FUS	Upper Story	911	911	911	238.91	217,643
WDK	Wood Deck	0	116	0	0.00	0
Ttl Gross Liv / Lease Area		1,321	1,692	1,321		315,594

