

CURRENT OWNER		TOPO	UTILITIES	STRT / ROAD	LOCATION	CURRENT ASSESSMENT				
CONIARIS, THOMAS D						Description	Code	Assessed	Assessed	801 FY2024 BARNSTABLE, MA
8 PARTRIDGE PATH						RESIDNTL	1020	291,100	291,100	
EAST SANDWIC MA 02537		SUPPLEMENTAL DATA				Total		291,100	291,100	VISION
Alt Prcl ID Split Zonin BID Parcel ResExpt Q #DL 1 UNIT 52 #DL 2 BLDG F GIS ID F_981842_2703782		Plan Ref. 447/55,59 Land Ct# #SR Life Estate PP STATU Assoc Pid#								

RECORD OF OWNERSHIP		BK-VOL/PAGE	SALE DATE	Q/U	V/I	SALE PRICE	VC	PREVIOUS ASSESSMENTS (HISTORY)								
CONIARIS, THOMAS D		27928	0170	01-10-2014	U	I	120,000	1	Year	Code	Assessed	Year	Code	Assessed		
DASILVA, ANDRE B & VIVIANE A		25644	0279	08-26-2011	U	I	83,000	1S	2023	1020	277,900	2022	1020	212,100		
FEDERAL HOME LOAN MORTGAGE CORPO		25235	0311	02-03-2011	U	I	128,000	1L				2021	1020	182,800		
FROIS, ROBERTO ALBINO & LUCILIA ALBIN		17733	0226	10-01-2003	Q	I	190,000	00					1020	3,600		
PABEDINSKAS, ANDRIUS L & ROSE MARIE		12682	0229	11-23-1999	Q	I	86,500	00	Total		277,900	Total		212,100	Total	186,400

EXEMPTIONS			OTHER ASSESSMENTS					
Year	Code	Description	Amount	Code	Description	Number	Amount	Comm Int
Total			0.00					

ASSESSING NEIGHBORHOOD			
Nbhd	Nbhd Name	B	Tracing
0001			Batch HYAN

NOTES			
This signature acknowledges a visit by a Data Collector or Assessor			
APPRAISED VALUE SUMMARY			
Appraised Bldg. Value (Card)			277,700
Appraised Xf (B) Value (Bldg)			9,800
Appraised Ob (B) Value (Bldg)			3,600
Appraised Land Value (Bldg)			0
Special Land Value			0
Total Appraised Parcel Value			291,100
Valuation Method			C
Total Appraised Parcel Value			291,100

BUILDING PERMIT RECORD							VISIT / CHANGE HISTORY							
Permit Id	Issue Date	Type	Description	Amount	Insp Date	% Comp	Date Comp	Comments	Date	Id	Type	Is	Cd	Purpost/Result
									04-23-2020	WD			FR	Field Review
									12-11-2018	SR	02		03	Cycl Insp Comp
									09-11-2014	TP	22		22	Change of Address
									09-16-2013	TP	03		16	In Office Review
									03-08-2000	JG			03	Cycl Insp Comp

LAND LINE VALUATION SECTION																	
B	Use Code	Description	Zone	Dist	Land Type	Land Units	Unit Price	Size Adj	Site Index	Cond.	Nbhd.	Nbhd. Adj	Notes	Location Adjustmen	Adj Unit P	Land Value	
1	102U	Condominium M	RB	4		0 SF	0.00	1.00000	5	1.00	0001	1.000		0.0000	0	0	
Total Card Land Units						0 SF	Parcel Total Land Area						0.00	Total Land Value			0

CONSTRUCTION DETAIL			CONSTRUCTION DETAIL (CONTINUED)		
Element	Cd	Description	Element	Cd	Description
Style	55	Condominium			
Model	05	Res Condo			
Bedrm Func	C	Average			
Stories	2	2 Stories			
Occupancy	0				
Interior Wall 1	05	Drywall			
Interior Wall 2					
Interior Floor 1	14	Carpet			
Interior Floor 2					
Heat Fuel	03	Gas			
Heat Type	04	Hot Air			
AC Type	01	None			
Bedrooms	02	2 Bedrooms			
Full Baths	2	2 Full			
Half Baths	0				
Extra Fixtures					
Total Rooms	4	4 Rooms			
Bath Style					
Kitchen Style					
Master Deed L	1273				
Bath Split	20	2 Full-0 Half			
Foundation	08	Mixed			
AC Type Alt					
Sewer Occupan					
CONDO DATA					
Parcel Id	104288	C 0760	Ownr	1.9	
	SEA MEADOW VIL	B 1	S 1		
Adjust Type	Code	Description	Factor%		
Condo Flr	2FU	SECOND FLOOR	100		
Condo Unit	MKT0	MKT0	100		
COST / MARKET VALUATION					
Building Value New		315,595			
Year Built		1988			
Effective Year Built		2003			
Depreciation Code		A			
Remodel Rating					
Year Remodeled					
Depreciation %		12			
Functional Obsol		0			
External Obsol		0			
Trend Factor		1			
Condition					
Condition %					
Percent Good		88			
Cns Sect Rcnld		277,700			
Dep % Ovr					
Dep Ovr Comment					
Misc Imp Ovr					
Misc Imp Ovr Comment					
Cost to Cure Ovr					
Cost to Cure Ovr Comment					

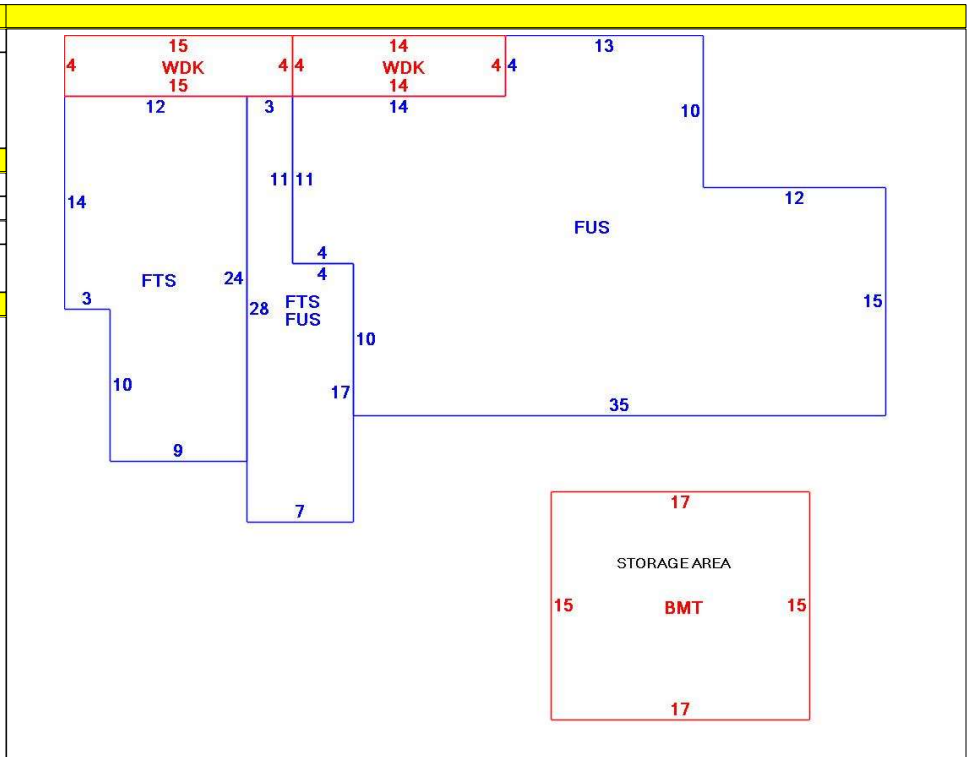

OB - OUTBUILDING & YARD ITEMS(L) / XF - BUILDING EXTRA FEATURES(B)										
Code	Description	L/B	Units	Unit Price	Yr Blt	Cond. Cd	% Gd	Grade	Grade Adj.	Appr. Value
BMT	Basement-Unfi	B	255	26.01	2005		88		0.00	9,800
WDC	Wood Decking	L	116	20.00	2018		98		0.00	3,600

BUILDING SUB-AREA SUMMARY SECTION						
Code	Description	Living Area	Floor Area	Eff Area	Unit Cost	Undeprec Value
BMT	Basement Area	0	255	0	0.00	0
FTS	Finished Third Story	410	410	410	238.91	97,951
FUS	Upper Story	911	911	911	238.91	217,643
WDC	Wood Deck	0	116	0	0.00	0
Ttl Gross Liv / Lease Area		1,321	1,692	1,321		315,594

