

CURRENT OWNER		TOPO	UTILITIES	STRT / ROAD	LOCATION	CURRENT ASSESSMENT						801 FY2024 BARNSTABLE, MA  <b>VISION</b>						
BARNSTABLE HOUSING AUTHORITY  146 SOUTH STREET  HYANNIS MA 02601						Description	Code	Assessed	Assessed									
		<b>SUPPLEMENTAL DATA</b>				EXEMPT	9700	228,300	228,300									
		Alt Prcl ID		Split Zonin		Plan Ref. 447/55,59												
		ResExpt Q		Land Ct#														
		#DL 1		Life Estate														
		#DL 2		PP STATU														
		GIS ID		Assoc Pid#														
		UNIT 53																
		BLDG F																
		F_981842_2703782																
						Total		228,300		228,300								
RECORD OF OWNERSHIP		BK-VOL/PAGE	SALE DATE	Q/U	V/I	SALE PRICE	VC	PREVIOUS ASSESSMENTS (HISTORY)										
BARNSTABLE HOUSING AUTHORITY		12490 0248	08-20-1999	U	I	63,750	1K	Year	Code	Assessed	Year	Code	Assessed					
POYANT, DIANE M & MICHELLE		6236 0256	04-15-1988	Q	I	92,000	U	2023	9700	217,900	2022	9700	166,200	2021				
SEA MEADOW VILLAGE ASSOC		6232 0003	04-15-1988	U	I	1	B							143,100				
														2,900				
								Total		217,900		Total		166,200				
								Total		217,900		Total		146,000				
EXEMPTIONS			OTHER ASSESSMENTS					This signature acknowledges a visit by a Data Collector or Assessor										
Year	Code	Description	Amount	Code	Description	Number	Amount	Comm	Int									
		Total	0.00															
ASSESSING NEIGHBORHOOD										<b>APPRAISED VALUE SUMMARY</b>								
Nbhd	Nbhd Name		B	Tracing		Batch												
0001						HYAN												
NOTES													Appraised Bldg. Value (Card)		218,100			
													Appraised Xf (B) Value (Bldg)		7,300			
													Appraised Ob (B) Value (Bldg)		2,900			
													Appraised Land Value (Bldg)		0			
													Special Land Value		0			
													Total Appraised Parcel Value		228,300			
													Valuation Method		C			
													Total Appraised Parcel Value		228,300			
BUILDING PERMIT RECORD								VISIT / CHANGE HISTORY										
Permit Id	Issue Date	Type	Description	Amount	Insp Date	% Comp	Date Comp	Comments	Date	Id	Type	Is	Cd	Purpost/Result				
									05-14-2020	GM	04		FR	Field Review				
									12-11-2018	SR	02		03	Cycl Insp Comp				
									09-16-2013	TP	03		16	In Office Review				
									06-15-2004	PT	02		01	Meas/Est				
									01-28-2000	JG			03	Cycl Insp Comp				
LAND LINE VALUATION SECTION																		
B	Use Code	Description	Zone	Dist	Land Type	Land Units	Unit Price	Size Adj	Site Index	Cond.	Nbhd.	Nbhd. Adj	Notes	Location Adjustmen	Adj Unit P	Land Value		
1	970U	Hsng Auth M-05	RB	4		0 SF	0.00	1.00000	5	1.00	0001	1.000		0.0000	0	0		
Total Card Land Units						0	SF	Parcel Total Land Area						0.00	Total Land Value			0

CONSTRUCTION DETAIL			CONSTRUCTION DETAIL (CONTINUED)		
Element	Cd	Description	Element	Cd	Description
Style	55	Condominium			
Model	05	Res Condo			
Bedrm Func	C	Average			
Stories	2	2 Stories			
Occupancy	0				
Interior Wall 1	05	Drywall			
Interior Wall 2					
Interior Floor 1	14	Carpet			
Interior Floor 2					
Heat Fuel	04	Electric			
Heat Type	07	Elec Baseboard			
AC Type	01	None			
Bedrooms	02	2 Bedrooms			
Full Baths	1	1 Full			
Half Baths	0				
Extra Fixtures					
Total Rooms	4	4 Rooms			
Bath Style					
Kitchen Style					
Master Deed L	971				
Bath Split	10	1 Full-0 Half			
Foundation	08	Mixed			
AC Type Alt					
Sewer Occupan					
<b>CONDO DATA</b>					
Parcel Id	104288	C 0760	Ownr	1.5	
	SEA MEADOW VIL	B 1	S 1		
Adjust Type	Code	Description	Factor%		
Condo Flr	2FE	SECOND FL END	100		
Condo Unit	MKT0	MKT0	100		
<b>COST / MARKET VALUATION</b>					
Building Value New		247,836			
Year Built		1988			
Effective Year Built		2003			
Depreciation Code		A			
Remodel Rating					
Year Remodeled					
Depreciation %		12			
Functional Obsol		0			
External Obsol		0			
Trend Factor		1			
Condition					
Condition %					
Percent Good		88			
Cns Sect Rcnd		218,100			
Dep % Ovr					
Dep Ovr Comment					
Misc Imp Ovr					
Misc Imp Ovr Comment					
Cost to Cure Ovr					
Cost to Cure Ovr Comment					

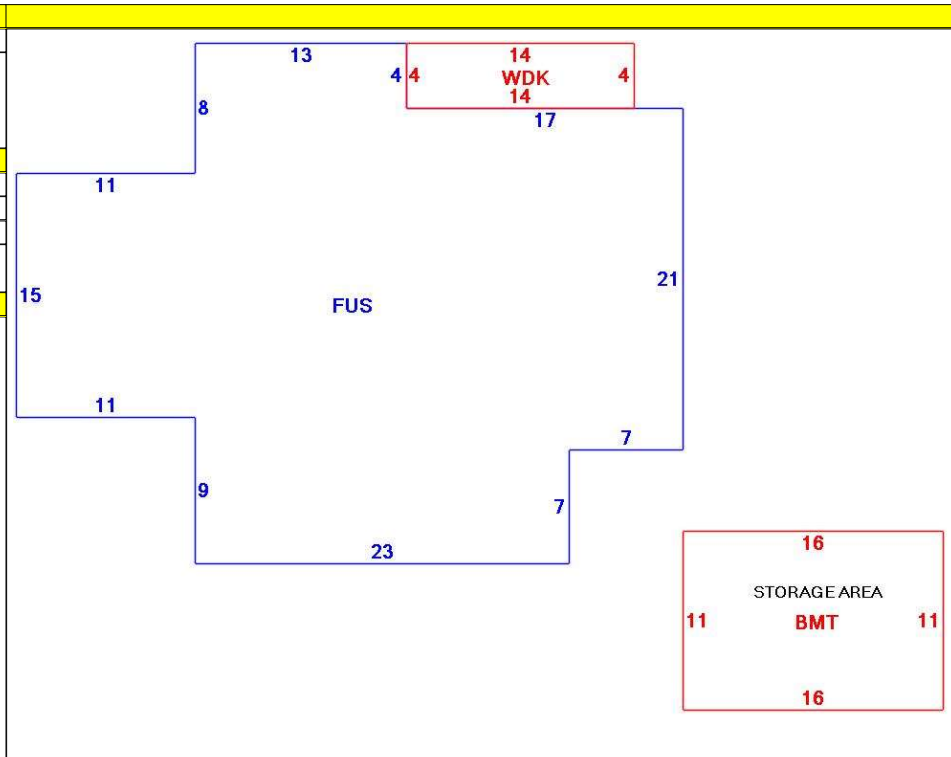

OB - OUTBUILDING & YARD ITEMS(L) / XF - BUILDING EXTRA FEATURES(B)										
Code	Description	L/B	Units	Unit Price	Yr Blt	Cond. Cd	% Gd	Grade	Grade Adj.	Appr. Value
BMT	Basement-Unfi	B	176	26.01	2005		88		0.00	7,300
WDC	Wood Decking	L	56	20.00	2018		98		0.00	2,900

BUILDING SUB-AREA SUMMARY SECTION						
Code	Description	Living Area	Floor Area	Eff Area	Unit Cost	Undeprec Value
BMT	Basement Area	0	176	0	0.00	0
FUS	Upper Story	1,008	1,008	1,008	245.87	247,836
WDC	Wood Deck	0	56	0	0.00	0
Ttl Gross Liv / Lease Area		1,008	1,240	1,008		247,836

