

CURRENT OWNER		TOPO	UTILITIES	STRT / ROAD	LOCATION	CURRENT ASSESSMENT				
FARNEZI, JOZANE M						Description	Code	Assessed	Assessed	801 FY2024 BARNSTABLE, MA
720 PITCHER'S WAY UNIT 54F		SUPPLEMENTAL DATA				RESIDNTL	1020	298,600	298,600	
HYANNIS	MA	02601	Alt Prcl ID Split Zonin BID Parcel ResExpt Q #DL 1 UNIT 54 #DL 2 BLDG F GIS ID F_981842_2703782		Plan Ref. 447/55,59 Land Ct# #SR Life Estate PP STATU Assoc Pid#	Total 298,600 298,600				

VISION

RECORD OF OWNERSHIP		BK-VOL/PAGE	SALE DATE	Q/U	V/I	SALE PRICE	VC	PREVIOUS ASSESSMENTS (HISTORY)								
FARNEZI, JOZANE M		32080 0158	06-11-2019	U	I	105,428	1	Year	Code	Assessed	Year	Code	Assessed	Year	Code	Assessed
BELL, BRUCE A & TEDI M		28337 0239	08-21-2014	U	I	100,000	1	2023	1020	285,000	2022	1020	217,400	2021	1020	187,500
ETLING, ELAINE		23562 0024	03-27-2009	U	I	0	1								1020	3,600
BRACKEN, MARIE P & ETLING, ELAINE		12884 0056	03-15-2000	Q	I	91,500	00	Total 285,000 Total 217,400 Total 191,100								
GORDON, H JON TR		11775 0065	10-21-1998	U	I	1	1A									

EXEMPTIONS			OTHER ASSESSMENTS					
Year	Code	Description	Amount	Code	Description	Number	Amount	Comm Int
Total			0.00					

This signature acknowledges a visit by a Data Collector or Assessor

ASSESSING NEIGHBORHOOD			
Nbhd	Nbhd Name	B	Tracing
0001			Batch HYAN

APPRAISED VALUE SUMMARY	
Appraised Bldg. Value (Card)	285,200
Appraised Xf (B) Value (Bldg)	9,800
Appraised Ob (B) Value (Bldg)	3,600
Appraised Land Value (Bldg)	0
Special Land Value	0
Total Appraised Parcel Value	298,600
Valuation Method	C
Total Appraised Parcel Value	298,600

BUILDING PERMIT RECORD						VISIT / CHANGE HISTORY								
Permit Id	Issue Date	Type	Description	Amount	Insp Date	% Comp	Date Comp	Comments	Date	Id	Type	Is	Cd	Purpost/Result
									04-23-2020	WD			FR	Field Review
									03-02-2020	SAF			20	Sale Review
									12-11-2018	SR	02		03	Cycl Insp Comp
									06-03-2015	TR	03		16	In Office Review
									09-17-2013	TP	03		16	In Office Review

LAND LINE VALUATION SECTION																		
B	Use Code	Description	Zone	Dist	Land Type	Land Units	Unit Price	Size Adj	Site Index	Cond.	Nbhd.	Nbhd. Adj	Notes	Location Adjustmen	Adj Unit P	Land Value		
1	102U	Condominium M	RB	4		0 SF	0.00	1.00000	5	1.00	0001	1.000		0.0000	0	0		
Total Card Land Units						0 SF	Parcel Total Land Area						0.00	Total Land Value				0

CONSTRUCTION DETAIL			CONSTRUCTION DETAIL (CONTINUED)		
Element	Cd	Description	Element	Cd	Description
Style	55	Condominium			
Model	05	Res Condo			
Bedrm Func	C	Average			
Stories	2	2 Stories			
Occupancy	0				
Interior Wall 1	05	Drywall			
Interior Wall 2					
Interior Floor 1	14	Carpet			
Interior Floor 2					
Heat Fuel	04	Electric			
Heat Type	07	Elec Baseboard			
AC Type	01	None			
Bedrooms	02	2 Bedrooms			
Full Baths	2	2 Full			
Half Baths	0				
Extra Fixtures					
Total Rooms	4	4 Rooms			
Bath Style					
Kitchen Style					
Master Deed L	1323				
Bath Split	20	2 Full-0 Half			
Foundation	08	Mixed			
AC Type Alt					
Sewer Occupan					
CONDO DATA					
Parcel Id	104288	C 0760	Owne	1.9	
	SEA MEADOW VIL	B 1	S 1		
Adjust Type	Code	Description	Factor%		
Condo Flr	2FE	SECOND FL END	100		
Condo Unit	MKT0	MKT0	100		
COST / MARKET VALUATION					
Building Value New		324,135			
Year Built		1988			
Effective Year Built		2003			
Depreciation Code		A			
Remodel Rating					
Year Remodeled		12			
Depreciation %		0			
Functional Obsol		0			
External Obsol		0			
Trend Factor		1			
Condition					
Condition %		88			
Percent Good		285,200			
Cns Sect Rcnd					
Dep % Ovr					
Dep Ovr Comment					
Misc Imp Ovr					
Misc Imp Ovr Comment					
Cost to Cure Ovr					
Cost to Cure Ovr Comment					

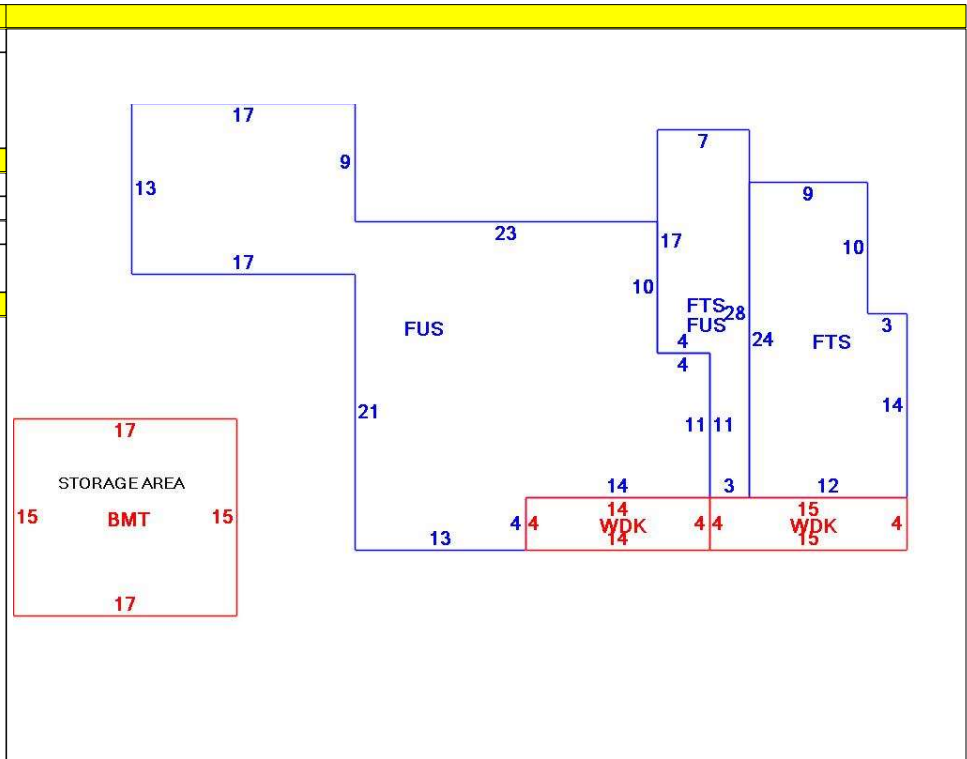

OB - OUTBUILDING & YARD ITEMS(L) / XF - BUILDING EXTRA FEATURES(B)										
Code	Description	L/B	Units	Unit Price	Yr Blt	Cond. Cd	% Gd	Grade	Grade Adj.	Appr. Value
BMT	Basement-Unfi	B	255	26.01	2005		88		0.00	9,800
WDC	Wood Decking	L	116	20.00	2018		98		0.00	3,600

BUILDING SUB-AREA SUMMARY SECTION						
Code	Description	Living Area	Floor Area	Eff Area	Unit Cost	Undeprec Value
BMT	Basement Area	0	255	0	0.00	0
FTS	Finished Third Story	410	410	410	237.98	97,574
FUS	Upper Story	952	952	952	237.98	226,561
WDC	Wood Deck	0	116	0	0.00	0
Ttl Gross Liv / Lease Area		1,362	1,733	1,362		324,135

