

| CURRENT OWNER  |  | TOPO    | UTILITIES   | STRT / ROAD | LOCATION | CURRENT ASSESSMENT    |      |          |          |
|--|--|---------|---|-------------|----------|-----------------------|------|----------|----------|
| WARFIELD, ROSEANNA P<br><br>619 FALMOUTH ROAD/RTE 28<br><br>HYANNIS MA 02601                             |  | 1 Level | 2 Public Water  | 1 Paved     |          | Description           | Code | Assessed | Assessed |
|  |  |         | 4 Gas   |             |          | RESIDNTL              | 1010 | 333,000  | 333,000  |
|  |  |         | 6 Septic  |             |          | RES LAND              | 1010 | 138,200  | 138,200  |
| <b>SUPPLEMENTAL DATA</b>   |  |         |   |             |          |                       |      |          |          |
| Alt Prcl ID<br>Split Zonin<br>BID Parcel<br>ResExpt Q<br>#DL 1 LOT 1<br>#DL 2<br>GIS ID F_981250_2703890 |  |         | Plan Ref.<br>Land Ct# 29356-A<br>#SR<br>Life Estate<br>PP STATU<br>Assoc Pid# |             |          | Total 471,200 471,200 |      |          |          |

801  
FY2024  
BARNSTABLE, MA

**VISION**

| RECORD OF OWNERSHIP             |         | BK-VOL/PAGE | SALE DATE  | Q/U | V/I | SALE PRIC | VC | PREVIOUS ASSESSMENTS (HISTORY) |      |          |       |      |          |
|---------------------------------|---------|-------------|------------|-----|-----|-----------|----|--------------------------------|------|----------|-------|------|----------|
| WARFIELD, ROSEANNA P            | D129389 | 0           | 05-06-2016 | U   | I   | 0         | 1A | Year                           | Code | Assessed | Year  | Code | Assessed |
| WARFIELD, GREGORY G SR & ROSEAN | C152158 | 0           | 03-01-1999 | U   | I   | 100       | 1A | 2023                           | 1010 | 295,400  | 2022  | 1010 | 248,000  |
| WARFIELD, ROSEANNA P            | C126468 | 0           | 05-15-1992 | Q   | I   | 120,000   | U  |                                | 1010 | 132,600  |       | 1010 | 98,200   |
| DACEY, WILLIAM E JR             | C107398 | 0           | 07-15-1986 | U   | I   | 1         | B  |                                |      |          |       | 1010 | 5,600    |
| ALL CAPE BUILDING CO INC        | C96287  | 0           | 04-15-1984 | U   | V   | 15,000    | Z  | Total                          |      | 428,000  | Total |      | 346,200  |
|                                 |         |             |            |     |     |           |    | Total                          |      |          | Total |      | 307,300  |

| EXEMPTIONS |      |                          | OTHER ASSESSMENTS |      |             |        |        |          |
|------------|------|--------------------------|-------------------|------|-------------|--------|--------|----------|
| Year       | Code | Description              | Amount            | Code | Description | Number | Amount | Comm Int |
| 2018       | N5C  | NO RESIDENTIAL EXEMPTION | 0.00              |      |             |        |        |          |
|            |      | Total                    | 0.00              |      |             |        |        |          |

This signature acknowledges a visit by a Data Collector or Assessor

| ASSESSING NEIGHBORHOOD |           |   |            |
|------------------------|-----------|---|------------|
| Nbhd                   | Nbhd Name | B | Tracing    |
| 0104                   |           |   | Batch HYAN |

| APPRAISED VALUE SUMMARY       |         |
|-------------------------------|---------|
| Appraised Bldg. Value (Card)  | 297,400 |
| Appraised Xf (B) Value (Bldg) | 30,000  |
| Appraised Ob (B) Value (Bldg) | 5,600   |
| Appraised Land Value (Bldg)   | 138,200 |
| Special Land Value            | 0       |
| Total Appraised Parcel Value  | 471,200 |
| Valuation Method              | C       |
| Total Appraised Parcel Value  | 471,200 |

| NOTES |  |  |  |  |  |  |  |  |  |
|-------|--|--|--|--|--|--|--|--|--|
|       |  |  |  |  |  |  |  |  |  |

| BUILDING PERMIT RECORD |            |      |             |        |            |        |            |                         | VISIT / CHANGE HISTORY |     |      |    |    |                            |
|------------------------|------------|------|-------------|--------|------------|--------|------------|-------------------------|------------------------|-----|------|----|----|----------------------------|
| Permit Id              | Issue Date | Type | Description | Amount | Insp Date  | % Comp | Date Comp  | Comments                | Date                   | Id  | Type | Is | Cd | Purpost/Result             |
| 201503548              | 06-15-2015 | WD   | Wood Deck   | 1,650  | 09-11-2015 | 100    | 06-30-2016 | ADDING ON TO AN EXISTIN | 04-27-2020             | WD  |      |    | FR | Field Review               |
| B34906                 | 03-01-1992 | AD   | Addition    | 15,000 | 01-15-1993 | 100    | 06-30-1993 | HY FINISH               | 09-28-2017             | MLF | 03   |    | 16 | In Office Review           |
|                        |            |      |             |        |            |        |            |                         | 04-19-2017             | LH  | 03   |    | 16 | In Office Review           |
|                        |            |      |             |        |            |        |            |                         | 02-19-2016             | SR  | 01   |    | 02 | Bldg Permit Completed      |
|                        |            |      |             |        |            |        |            |                         | 02-14-2014             | JR  | 03   |    | 16 | In Office Review           |
|                        |            |      |             |        |            |        |            |                         | 05-20-2002             | PT  | 01   |    | 00 | Meas/Listed-Interior Acces |
|                        |            |      |             |        |            |        |            |                         | 09-15-1989             | ML  | 01   |    | 00 | Meas/Listed-Interior Acces |

| LAND LINE VALUATION SECTION |          |                |      |    |            |            |                        |         |            |       |       |           |                  |                    |            |            |           |         |
|-----------------------------|----------|----------------|------|----|------------|------------|------------------------|---------|------------|-------|-------|-----------|------------------|--------------------|------------|------------|-----------|---------|
| B                           | Use Code | Description    | Zone | LA | Land Units | Unit Price | Size Adj               | AC Disc | Site Index | Cond. | Nbhd. | Nbhd. Adj | Notes            | Location Adjustmen | Adj Unit P | Land Value |           |         |
| 1                           | 1010     | Single Fam M-0 | RB   | 4  | 0.390      | AC         | 176,344.00             | 2.23277 | 1.0000     | 5     | 1.00  | 0104      | 0.900            | ROUTE 28           |            | 1.0000     | 354,363.2 | 138,200 |
| Total Card Land Units       |          |                |      |    | 0.39       | AC         | Parcel Total Land Area |         |            |       |       | 0.39      | Total Land Value |                    |            | 138,200    |           |         |

| CONSTRUCTION DETAIL |      |                | CONSTRUCTION DETAIL (CONTINUED) |    |             |
|---------------------|------|----------------|---------------------------------|----|-------------|
| Element             | Cd   | Description    | Element                         | Cd | Description |
| Style               | 04   | Cape Cod       |                                 |    |             |
| Model               | 01   | Residential    |                                 |    |             |
| Grade:              | C    | Average        |                                 |    |             |
| Stories             | 1.75 | 1 3/4 Stories  |                                 |    |             |
| Exterior Wall 1     | 14   | Wood Shingle   |                                 |    |             |
| Exterior Wall 2     | 11   | Clapboard      |                                 |    |             |
| Roof Structure      | 03   | Gable/Hip      |                                 |    |             |
| Roof Cover          | 03   | Asph/F Gls/Cmp |                                 |    |             |
| Interior Wall 1     | 05   | Drywall        |                                 |    |             |
| Interior Wall 2     |      |                |                                 |    |             |
| Interior Floor 1    | 14   | Carpet         |                                 |    |             |
| Interior Floor 2    | 12   | Hardwood       |                                 |    |             |
| Heat Fuel           | 04   | Electric       |                                 |    |             |
| Heat Type           | 07   | Elec Baseboard |                                 |    |             |
| AC Type             | 01   | None           |                                 |    |             |
| Bedrooms            | 04   | 4 Bedrooms     |                                 |    |             |
| Full Baths          | 2    |                |                                 |    |             |
| Half Baths          | 0    |                |                                 |    |             |
| Extra Fixtures      |      |                |                                 |    |             |
| Total Rooms         | 6    | 6 Rooms        |                                 |    |             |
| Bath Style          |      |                |                                 |    |             |
| Kitchen Style       |      |                |                                 |    |             |
| Occupancy           |      |                |                                 |    |             |
| Usrflid 105         |      |                |                                 |    |             |
| Accessory Apt       |      |                |                                 |    |             |
| Foundation Alt      | 01   | Poured Conc.   |                                 |    |             |
| Rms Prts            |      |                |                                 |    |             |
| Bath Split          | 20   | 2 Full-0 Half  |                                 |    |             |

| CONDO DATA  |      |             |          |
|-------------|------|-------------|----------|
| Parcel Id   |      | C           | Ownr 0.0 |
| Adjust Type | Code | Description | Factor%  |
| Condo Flr   |      |             |          |
| Condo Unit  |      |             |          |

| COST / MARKET VALUATION  |         |
|--------------------------|---------|
| Building Value New       | 354,059 |
| Year Built               | 1984    |
| Effective Year Built     | 1998    |
| Depreciation Code        | A       |
| Remodel Rating           |         |
| Year Remodeled           |         |
| Depreciation %           | 16      |
| Functional Obsol         | 0       |
| External Obsol           | 0       |
| Trend Factor             | 1       |
| Condition                |         |
| Condition %              |         |
| Percent Good             | 84      |
| RCNLD                    | 297,400 |
| Dep % Ovr                |         |
| Dep Ovr Comment          |         |
| Misc Imp Ovr             |         |
| Misc Imp Ovr Comment     |         |
| Cost to Cure Ovr         |         |
| Cost to Cure Ovr Comment |         |

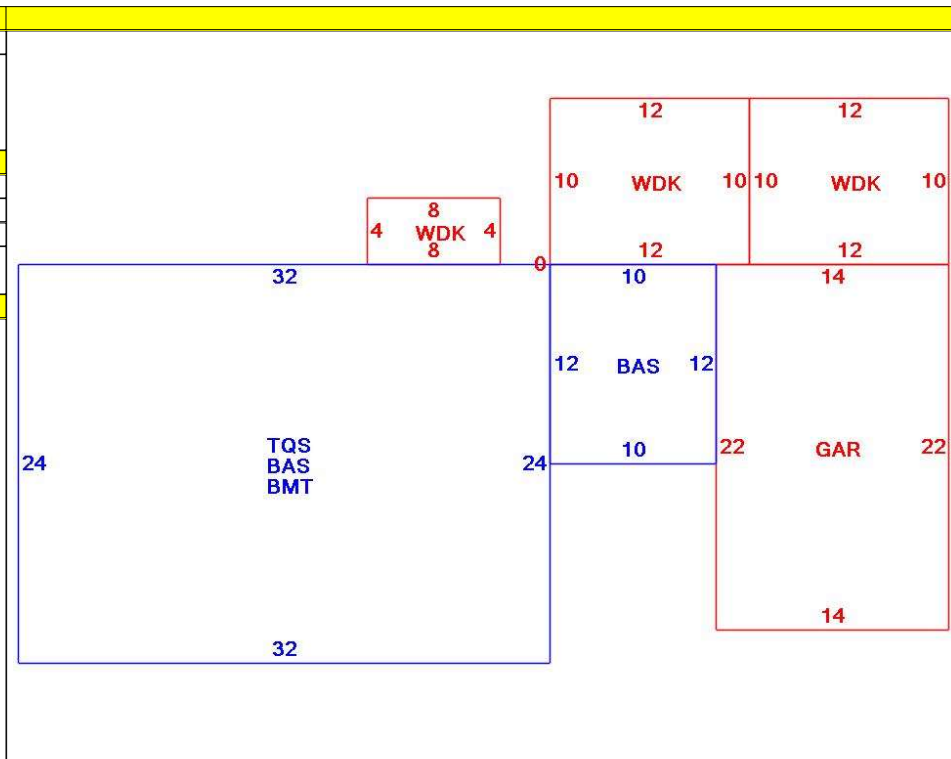

| OB - OUTBUILDING & YARD ITEMS(L) / XF - BUILDING EXTRA FEATURES(B) |               |     |       |            |        |          |      |       |            |             |
|--|---------------|-----|-------|------------|--------|----------|------|-------|------------|-------------|
| Code   | Description   | L/B | Units | Unit Price | Yr Blt | Cond. Cd | % Gd | Grade | Grade Adj. | Appr. Value |
| WDC  | Wood Decking  | L   | 152   | 20.00      | 1999   |          | 60   |       | 0.00       | 2,500       |
| GAR  | Attached Gara | B   | 308   | 40.00      | 2000   |          | 84   |       | 0.00       | 11,400      |
| BMT  | Basement-Unfi | B   | 768   | 26.01      | 2000   |          | 84   |       | 0.00       | 18,600      |
| WDC  | Wood Deck w/  | L   | 120   | 18.00      | 2015   |          | 92   |       | 0.00       | 3,100       |

| BUILDING SUB-AREA SUMMARY SECTION |                     |             |            |          |           |                |
|-----------------------------------|---------------------|-------------|------------|----------|-----------|----------------|
| Code                              | Description         | Living Area | Floor Area | Eff Area | Unit Cost | Undeprec Value |
| BAS                               | First Floor         | 888         | 888        | 888      | 255.27    | 226,680        |
| BMT                               | Basement Area       | 0           | 768        | 0        | 0.00      | 0              |
| GAR                               | Attached Garage     | 0           | 308        | 0        | 0.00      | 0              |
| TQS                               | Three Quarter Story | 499         | 768        | 499      | 165.86    | 127,380        |
| WDK                               | Wood Deck           | 0           | 272        | 0        | 0.00      | 0              |
| Ttl Gross Liv / Lease Area        |                     | 1,387       | 3,004      | 1,387    |           | 354,060        |

