

| CURRENT OWNER | | | | TOPO | UTILITIES | STRT / ROAD | LOCATION | CURRENT ASSESSMENT | | | | | | |
|-------------------------|--|--|--|------|-----------|------------------|----------|--------------------|------|----------|----------|---------------------------------|---------|---------|
| BELL, STEPHEN M | | | | | | | | Description | Code | Assessed | Assessed | 801 FY2024 BARNSTABLE, MA | | |
| 1310 BLUEGRASS WAY | | | | | | | | RESIDNTL | 1010 | 538,400 | 538,400 | | | |
| GAMBRILLS MD 21054 | | | | | | | | RES LAND | 1010 | 139,600 | 139,600 | | | |
| SUPPLEMENTAL DATA | | | | | | | | | | | | VISION | | |
| Alt Prcl ID | | | | | | Plan Ref. 425/33 | | Total | | | | | 678,000 | 678,000 |
| Split Zonin | | | | | | Land Ct# | | | | | | | | |
| ResExpt Q | | | | | | Life Estate | | | | | | | | |
| #DL 1 LOT 68 | | | | | | PP STATU | | | | | | | | |
| #DL 2 | | | | | | Assoc Pid# | | | | | | | | |
| GIS ID F_980292_2705666 | | | | | | | | | | | | | | |

| RECORD OF OWNERSHIP | | | | BK-VOL/PAGE | SALE DATE | Q/U | V/I | SALE PRIC | VC | PREVIOUS ASSESSMENTS (HISTORY) | | | | | | | | |
|--------------------------------|--|--|--|-------------|------------|-----|-----|-----------|----|--------------------------------|------|----------|-------|------|----------|-------|--|---------|
| BELL, STEPHEN M | | | | 20579 0156 | 12-16-2005 | Q | I | 475,000 | 00 | Year | Code | Assessed | Year | Code | Assessed | | | |
| EASTERDAY, CHARLES L & DIANE L | | | | 14275 0127 | 09-27-2001 | U | I | 320,000 | 1 | 2023 | 1010 | 481,000 | 2022 | 1010 | 401,300 | | | |
| DACEY, BRIAN T TR | | | | 11096 0080 | 12-03-1997 | U | V | 1,969,000 | 1 | | 1010 | 126,900 | | 1010 | 94,000 | | | |
| COBBLESTONE LANDING INC | | | | 9128 0054 | 04-15-1994 | U | V | 100 | 1F | | | | | 1010 | 3,100 | | | |
| FRANCO R E DEV CO, INC | | | | 7851 0158 | 01-28-1992 | U | V | 1 | 1 | Total | | 607,900 | Total | | 495,300 | Total | | 434,100 |

| EXEMPTIONS | | | | OTHER ASSESSMENTS | | | | This signature acknowledges a visit by a Data Collector or Assessor | | | | | | | | | | | | |
|------------|------|-------------|--------|-------------------|-------------|--------|--------|---|--|--|--|--|--|--|--|--|--|--|--|--|
| Year | Code | Description | Amount | Code | Description | Number | Amount | Comm Int | | | | | | | | | | | | |
| | | | | | | | | | | | | | | | | | | | | |
| Total | | | 0.00 | | | | | | | | | | | | | | | | | |

| ASSESSING NEIGHBORHOOD | | | | APPRAISED VALUE SUMMARY | | | |
|------------------------|-----------|---|---------|-------------------------|--|--|--|
| Nbhd | Nbhd Name | B | Tracing | Batch | | | |
| 0107 | | | | HYAN | | | |

| NOTES | | | | | | | | | | | | APPRAISED VALUE SUMMARY | | | |
|-------|--|--|--|--|--|--|--|--|--|--|--|-------------------------------|---------|--|--|
| | | | | | | | | | | | | Appraised Bldg. Value (Card) | 494,800 | | |
| | | | | | | | | | | | | Appraised Xf (B) Value (Bldg) | 40,500 | | |
| | | | | | | | | | | | | Appraised Ob (B) Value (Bldg) | 3,100 | | |
| | | | | | | | | | | | | Appraised Land Value (Bldg) | 139,600 | | |
| | | | | | | | | | | | | Special Land Value | 0 | | |
| | | | | | | | | | | | | Total Appraised Parcel Value | 678,000 | | |
| | | | | | | | | | | | | Valuation Method | C | | |
| | | | | | | | | | | | | Total Appraised Parcel Value | 678,000 | | |

| BUILDING PERMIT RECORD | | | | | | | | VISIT / CHANGE HISTORY | | | | | | | |
|------------------------|------------|------|-------------|---------|------------|--------|------------|------------------------|------------|----|------|----|----|----------------------|--|
| Permit Id | Issue Date | Type | Description | Amount | Insp Date | % Comp | Date Comp | Comments | Date | Id | Type | Is | Cd | Purpost/Result | |
| 52443 | 03-29-2001 | DW | Dwelling | 172,700 | 05-09-2002 | 100 | 01-01-2002 | | 04-27-2020 | WD | | | FR | Field Review | |
| | | | | | | | | | 12-01-2017 | KM | 02 | | 03 | Cycl Insp Comp | |
| | | | | | | | | | 03-21-2017 | AL | 22 | | 22 | Change of Address | |
| | | | | | | | | | 08-08-2014 | JR | 03 | | 16 | In Office Review | |
| | | | | | | | | | 07-29-2013 | DR | 22 | | 22 | Change of Address | |
| | | | | | | | | | 10-13-2011 | RB | 03 | | 16 | In Office Review | |
| | | | | | | | | | 03-07-2006 | JS | 02 | | 49 | N/C - Cyclical Insp. | |

| LAND LINE VALUATION SECTION | | | | | | | | | | | | | | | | |
|-----------------------------|----------|----------------|------|----|------------|------------|------------------------|---------|------------|-------|-------|-----------|------------------|--------------------|------------|------------|
| B | Use Code | Description | Zone | LA | Land Units | Unit Price | Size Adj | AC Disc | Site Index | Cond. | Nbhd. | Nbhd. Adj | Notes | Location Adjustmen | Adj Unit P | Land Value |
| 1 | 1010 | Single Fam M-0 | RC- | 4 | 0.170 AC | 176,344.00 | 4.65505 | 1.0000 | 5 | 1.00 | 0105 | 1.000 | | 1.0000 | 820,898.9 | 139,600 |
| Total Card Land Units | | | | | 0.17 | AC | Parcel Total Land Area | | | | | 0.17 | Total Land Value | | | 139,600 |

| CONSTRUCTION DETAIL | | | CONSTRUCTION DETAIL (CONTINUED) | | |
|---------------------|------|----------------|---------------------------------|------|-------------|
| Element | Cd | Description | Element | Cd | Description |
| Style | 04 | Cape Cod | | | |
| Model | 01 | Residential | | | |
| Grade: | C+ | Average Plus | | | |
| Stories | 1.75 | 1 3/4 Stories | | | |
| Exterior Wall 1 | 14 | Wood Shingle | | | |
| Exterior Wall 2 | 11 | Clapboard | | | |
| RooF Structure | 03 | Gable/Hip | | | |
| RooF Cover | 03 | Asph/F Gls/Cmp | | | |
| Interior Wall 1 | 03 | Plastered | | | |
| Interior Wall 2 | | | | | |
| Interior Floor 1 | 12 | Hardwood | | | |
| Interior Floor 2 | 14 | Carpet | | | |
| Heat Fuel | 03 | Gas | | | |
| Heat Type | 04 | Hot Air | | | |
| AC Type | 03 | Central | | | |
| Bedrooms | 03 | 3 Bedrooms | | | |
| Full Baths | 2 | | | | |
| Half Baths | 1 | | | | |
| Extra Fixtures | | | | | |
| Total Rooms | 7 | 7 Rooms | | | |
| Bath Style | | | | | |
| Kitchen Style | | | | | |
| Occupancy | | | | | |
| UsrflD 105 | | | | | |
| Accessory Apt | | | | | |
| Foundation Alt | 01 | Poured Conc. | | | |
| Rms Prts | | | | | |
| Bath Split | 21 | 2 Full-1 Half | | | |
| | | | CONDO DATA | | |
| | | | Parcel Id | | C |
| | | | Owne 0.0 | | |
| | | | B S | | |
| | | | Adjust Type | Code | Description |
| | | | Condo Flr | | |
| | | | Condo Unit | | |
| | | | COST / MARKET VALUATION | | |
| | | | Building Value New 549,755 | | |
| | | | Year Built 2001 | | |
| | | | Effective Year Built 2006 | | |
| | | | Depreciation Code A | | |
| | | | Remodel Rating | | |
| | | | Year Remodeled | | |
| | | | Depreciation % 10 | | |
| | | | Functional Obsol 0 | | |
| | | | External Obsol 0 | | |
| | | | Trend Factor 1 | | |
| | | | Condition | | |
| | | | Condition % | | |
| | | | Percent Good 90 | | |
| | | | RCNLD 494,800 | | |
| | | | Dep % Ovr | | |
| | | | Dep Ovr Comment | | |
| | | | Misc Imp Ovr | | |
| | | | Misc Imp Ovr Comment | | |
| | | | Cost to Cure Ovr | | |
| | | | Cost to Cure Ovr Comment | | |

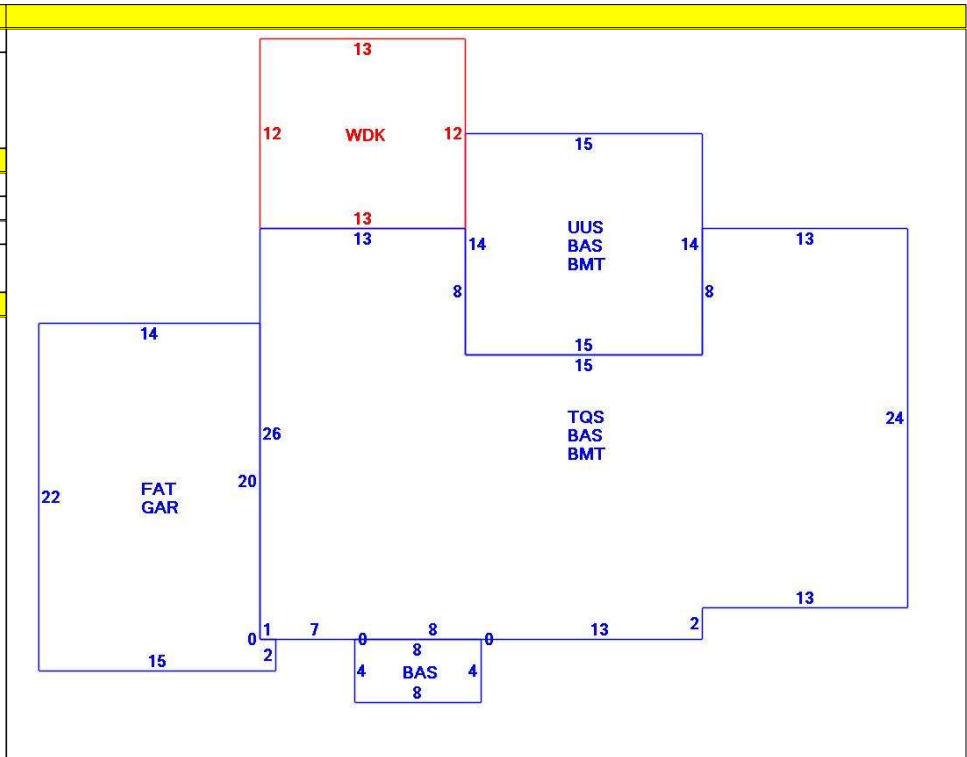

| OB - OUTBUILDING & YARD ITEMS(L) / XF - BUILDING EXTRA FEATURES(B) | | | | | | | | | | |
|--|----------------|-----|-------|------------|--------|----------|------|-------|------------|-------------|
| Code | Description | L/B | Units | Unit Price | Yr Blt | Cond. Cd | % Gd | Grade | Grade Adj. | Appr. Value |
| FPLG | Gas Fireplace- | B | 1 | 2500.00 | 2008 | | 90 | | 0.00 | 2,300 |
| WDC | Wood Decking | L | 156 | 20.00 | 2006 | | 74 | | 0.00 | 3,100 |
| GAR | Attached Gara | B | 310 | 40.00 | 2008 | | 90 | | 0.00 | 12,300 |
| BMT | Basement-Unfi | B | 1,130 | 26.01 | 2008 | | 90 | | 0.00 | 25,900 |

| BUILDING SUB-AREA SUMMARY SECTION | | | | | | |
|-----------------------------------|-------------------------|-------------|------------|----------|-----------|----------------|
| Code | Description | Living Area | Floor Area | Eff Area | Unit Cost | Undeprec Value |
| BAS | First Floor | 1,162 | 1,162 | 1,162 | 276.82 | 321,659 |
| BMT | Basement Area | 0 | 1,130 | 0 | 0.00 | 0 |
| FAT | Attic, Finished | 47 | 310 | 47 | 41.97 | 13,010 |
| GAR | Attached Garage | 0 | 310 | 0 | 0.00 | 0 |
| TQS | Three Quarter Story | 598 | 920 | 598 | 179.93 | 165,535 |
| UUS | Upper Story, Unfinished | 0 | 210 | 179 | 235.95 | 49,550 |
| WDK | Wood Deck | 0 | 156 | 0 | 0.00 | 0 |
| Ttl Gross Liv / Lease Area | | 1,807 | 4,198 | 1,986 | | 549,754 |

