

| CURRENT OWNER | | | TOPO | UTILITIES | STRT / ROAD | LOCATION | CURRENT ASSESSMENT | | | | |
|----------------------------|-------------|------------|-----------|-----------|-------------|----------|--------------------|--------|------------------|-------------|---------------------------------|
| POIRIER, BARBARA A & KAREN | | | | | | | Description | Code | Assessed | Assessed | 801 FY2024 BARNSTABLE, MA |
| 27 FLOODTIDE LANE | | | | | | | RESIDNTL | 1010 | 490,200 | 490,200 | |
| HYANNIS MA 02601 | | | | | | | RES LAND | 1010 | 142,000 | 142,000 | VISION |
| SUPPLEMENTAL DATA | | | | | | | Total | | 632,200 | 632,200 | |
| Alt Prcl ID | Split Zonin | BID Parcel | ResExpt Q | YES: | #DL 1 | LOT 72 | #DL 2 | GIS ID | F_980168_2705448 | Plan Ref. | |
| | | | | | | | | | | Land Ct# | |
| | | | | | | | | | | #SR | |
| | | | | | | | | | | Life Estate | |
| | | | | | | | | | | PP STATU | |
| | | | | | | | | | | Assoc Pid# | |

| RECORD OF OWNERSHIP | | | BK-VOL/PAGE | SALE DATE | Q/U | V/I | SALE PRIC | VC | PREVIOUS ASSESSMENTS (HISTORY) | | | | |
|-----------------------------------|-------|------|-------------|-----------|-----|-----------|-----------|-------|--------------------------------|----------|-------|------|----------|
| POIRIER, BARBARA A & KAREN | 27069 | 0189 | 01-24-2013 | U | I | 1 | 1F | Year | Code | Assessed | Year | Code | Assessed |
| POIRIER, GERALD D & BARBARA A TRS | 16112 | 0018 | 12-19-2002 | U | I | 100 | 1F | 2023 | 1010 | 425,500 | 2022 | 1010 | 366,400 |
| POIRIER, GERALD D & BARBARA A | 16112 | 0008 | 12-19-2002 | U | I | 100 | 1A | | 1010 | 129,100 | 2021 | 1010 | 95,600 |
| POIRIER, GERALD D & BARBARA A | 13742 | 0108 | 04-19-2001 | U | I | 292,500 | 1 | | | | | 1010 | 4,000 |
| DACEY, BRIAN T TR | 11096 | 0080 | 12-03-1997 | U | V | 1,969,000 | 1 | Total | | 554,600 | Total | | 462,000 |
| | | | | | | | | Total | | 392,000 | Total | | 392,000 |

| EXEMPTIONS | | | | OTHER ASSESSMENTS | | | |
|------------|------|-----------------------|--------|-------------------|-------------|--------|--------|
| Year | Code | Description | Amount | Code | Description | Number | Amount |
| 2024 | 5C | RESIDENTIAL EXEMPTION | 0.00 | | | | |
| Total | | | 0.00 | | | | |

| ASSESSING NEIGHBORHOOD | | | |
|------------------------|-----------|---|---------------|
| Nbhd | Nbhd Name | B | Tracing |
| 0107 | | | Batch HYAN |

| NOTES | | | |
|---------------------------------------------------------------------|--|--|---------|
| This signature acknowledges a visit by a Data Collector or Assessor | | | |
| APPRAISED VALUE SUMMARY | | | |
| Appraised Bldg. Value (Card) | | | 435,400 |
| Appraised Xf (B) Value (Bldg) | | | 50,800 |
| Appraised Ob (B) Value (Bldg) | | | 4,000 |
| Appraised Land Value (Bldg) | | | 142,000 |
| Special Land Value | | | 0 |
| Total Appraised Parcel Value | | | 632,200 |
| Valuation Method | | | C |
| Total Appraised Parcel Value | | | 632,200 |

| BUILDING PERMIT RECORD | | | | | | | | | VISIT / CHANGE HISTORY | | | | | |
|------------------------|------------|------|-------------|---------|------------|--------|------------|----------|------------------------|----|------|----|----|----------------------------|
| Permit Id | Issue Date | Type | Description | Amount | Insp Date | % Comp | Date Comp | Comments | Date | Id | Type | Is | Cd | Purpost/Result |
| 50303 | 12-01-2000 | DW | Dwelling | 164,270 | 02-05-2001 | 100 | 01-01-2002 | FND ONLY | 10-16-2023 | EG | 03 | | 16 | In Office Review |
| | | | | | | | | | 04-27-2020 | WD | | | FR | Field Review |
| | | | | | | | | | 01-12-2018 | KM | 02 | | 03 | Cycl Insp Comp |
| | | | | | | | | | 05-09-2002 | MF | 01 | | 00 | Meas/Listed-Interior Acces |
| | | | | | | | | | 02-05-2001 | MF | 02 | | 05 | Measur/New UC Under C |

| LAND LINE VALUATION SECTION | | | | | | | | | | | | | | | | |
|-----------------------------|----------|----------------|------|----|------------|------------|------------------------|---------|------------|-------|-------|-----------|------------------|--------------------|------------|------------|
| B | Use Code | Description | Zone | LA | Land Units | Unit Price | Size Adj | AC Disc | Site Index | Cond. | Nbhd. | Nbhd. Adj | Notes | Location Adjustmen | Adj Unit P | Land Value |
| 1 | 1010 | Single Fam M-0 | RC- | 4 | 0.190 | AC | 176,344.00 | 4.23746 | 1.0000 | 5 | 1.00 | 0105 | 1.000 | | 1.0000 | 747,257.7 |
| Total Card Land Units | | | | | 0.19 | AC | Parcel Total Land Area | | | | | 0.19 | Total Land Value | | | 142,000 |

| CONSTRUCTION DETAIL | | | CONSTRUCTION DETAIL (CONTINUED) | | |
|---------------------|----|----------------|---------------------------------|----|-------------|
| Element | Cd | Description | Element | Cd | Description |
| Style | 01 | Ranch | | | |
| Model | 01 | Residential | | | |
| Grade: | C+ | Average Plus | | | |
| Stories | 1 | 1 Story | | | |
| Exterior Wall 1 | 14 | Wood Shingle | | | |
| Exterior Wall 2 | 11 | Clapboard | | | |
| Roof Structure | 03 | Gable/Hip | | | |
| Roof Cover | 03 | Asph/F Gls/Cmp | | | |
| Interior Wall 1 | 05 | Drywall | | | |
| Interior Wall 2 | | | | | |
| Interior Floor 1 | 12 | Hardwood | | | |
| Interior Floor 2 | 14 | Carpet | | | |
| Heat Fuel | 03 | Gas | | | |
| Heat Type | 04 | Hot Air | | | |
| AC Type | 03 | Central | | | |
| Bedrooms | 03 | 3 Bedrooms | | | |
| Full Baths | 2 | | | | |
| Half Baths | 0 | | | | |
| Extra Fixtures | | | | | |
| Total Rooms | 7 | 7 Rooms | | | |
| Bath Style | | | | | |
| Kitchen Style | | | | | |
| Occupancy | | | | | |
| Usrflid 105 | | | | | |
| Accessory Apt | | | | | |
| Foundation Alt | 01 | Poured Conc. | | | |
| Rms Prts | | | | | |
| Bath Split | 20 | 2 Full-0 Half | | | |

| CONDO DATA | | | | | |
|-------------|------|-------------|---------|------|-----|
| Parcel Id | | C | | Owne | 0.0 |
| Adjust Type | Code | Description | Factor% | | |
| Condo Flr | | | | | |
| Condo Unit | | | | | |

| COST / MARKET VALUATION | | | |
|--------------------------|--|---------|--|
| Building Value New | | 483,732 | |
| Year Built | | 2001 | |
| Effective Year Built | | 2006 | |
| Depreciation Code | | A | |
| Remodel Rating | | | |
| Year Remodeled | | | |
| Depreciation % | | 10 | |
| Functional Obsol | | 0 | |
| External Obsol | | 0 | |
| Trend Factor | | 1 | |
| Condition | | | |
| Condition % | | | |
| Percent Good | | 90 | |
| RCNLD | | 435,400 | |
| Dep % Ovr | | | |
| Dep Ovr Comment | | | |
| Misc Imp Ovr | | | |
| Misc Imp Ovr Comment | | | |
| Cost to Cure Ovr | | | |
| Cost to Cure Ovr Comment | | | |

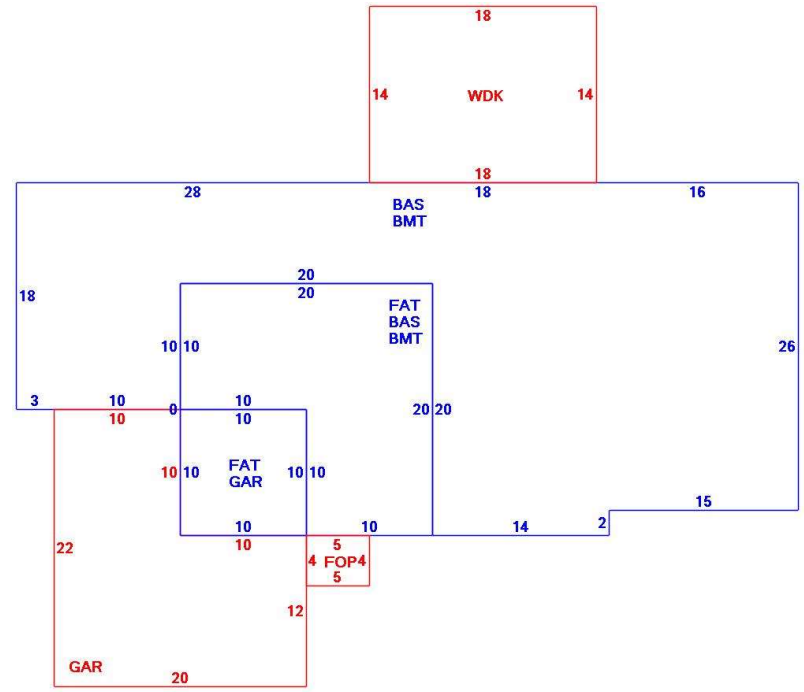

| OB - OUTBUILDING & YARD ITEMS(L) / XF - BUILDING EXTRA FEATURES(B) | | | | | | | | | | |
|--------------------------------------------------------------------|----------------|-----|-------|------------|--------|----------|------|-------|------------|-------------|
| Code | Description | L/B | Units | Unit Price | Yr Blt | Cond. Cd | % Gd | Grade | Grade Adj. | Appr. Value |
| WDC | Wood Decking | L | 252 | 20.00 | 2006 | | 74 | | 0.00 | 4,000 |
| FOP | Open Porch-ro | B | 20 | 55.00 | 2008 | | 90 | | 0.00 | 1,600 |
| GAR | Attached Gara | B | 440 | 40.00 | 2008 | | 90 | | 0.00 | 15,400 |
| BMT | Basement-Unfi | B | 1,476 | 26.01 | 2008 | | 90 | | 0.00 | 31,500 |
| FPLG | Gas Fireplace- | B | 1 | 2500.00 | 2008 | | 90 | | 0.00 | 2,300 |

| BUILDING SUB-AREA SUMMARY SECTION | | | | | | |
|-----------------------------------|-----------------|-------------|------------|----------|-----------|----------------|
| Code | Description | Living Area | Floor Area | Eff Area | Unit Cost | Undeprec Value |
| BAS | First Floor | 1,476 | 1,476 | 1,476 | 314.93 | 464,837 |
| BMT | Basement Area | 0 | 1,476 | 0 | 0.00 | 0 |
| FAT | Attic, Finished | 60 | 400 | 60 | 47.24 | 18,896 |
| FOP | Open Porch | 0 | 20 | 0 | 0.00 | 0 |
| GAR | Attached Garage | 0 | 440 | 0 | 0.00 | 0 |
| WDK | Wood Deck | 0 | 252 | 0 | 0.00 | 0 |
| Ttl Gross Liv / Lease Area | | 1,536 | 4,064 | 1,536 | | 483,733 |

