

CONSTRUCTION DETAIL			CONSTRUCTION DETAIL (CONTINUED)		
Element	Cd	Description	Element	Cd	Description
Style	04	Cape Cod			
Model	01	Residential			
Grade:	C	Average			
Stories	1.75	1 3/4 Stories			
Exterior Wall 1	14	Wood Shingle			
Exterior Wall 2	11	Clapboard			
RooF Structure	03	Gable/Hip			
RooF Cover	03	Asph/F Gls/Cmp			
Interior Wall 1	05	Drywall			
Interior Wall 2					
Interior Floor 1	14	Carpet			
Interior Floor 2	12	Hardwood			
Heat Fuel	03	Gas			
Heat Type	04	Hot Air			
AC Type	01	None			
Bedrooms	03	3 Bedrooms			
Full Baths	2				
Half Baths	0				
Extra Fixtures					
Total Rooms	6	6 Rooms			
Bath Style					
Kitchen Style					
Occupancy					
UsrflD 105					
Accessory Apt					
Foundation Alt	01	Poured Conc.			
Rms Prts					
Bath Split	20	2 Full-0 Half			

CONDO DATA			
Parcel Id	C	Ownr	0.0
Adjust Type	Code	Description	Factor%
Condo Flr	Condo Unit		

COST / MARKET VALUATION	
Building Value New	365,259
Year Built	1971
Effective Year Built	1991
Depreciation Code	A
Remodel Rating	
Year Remodeled	
Depreciation %	22
Functional Obsol	0
External Obsol	0
Trend Factor	1
Condition	
Condition %	
Percent Good	78
RCNLD	284,900
Dep % Ovr	
Dep Ovr Comment	
Misc Imp Ovr	
Misc Imp Ovr Comment	
Cost to Cure Ovr	
Cost to Cure Ovr Comment	

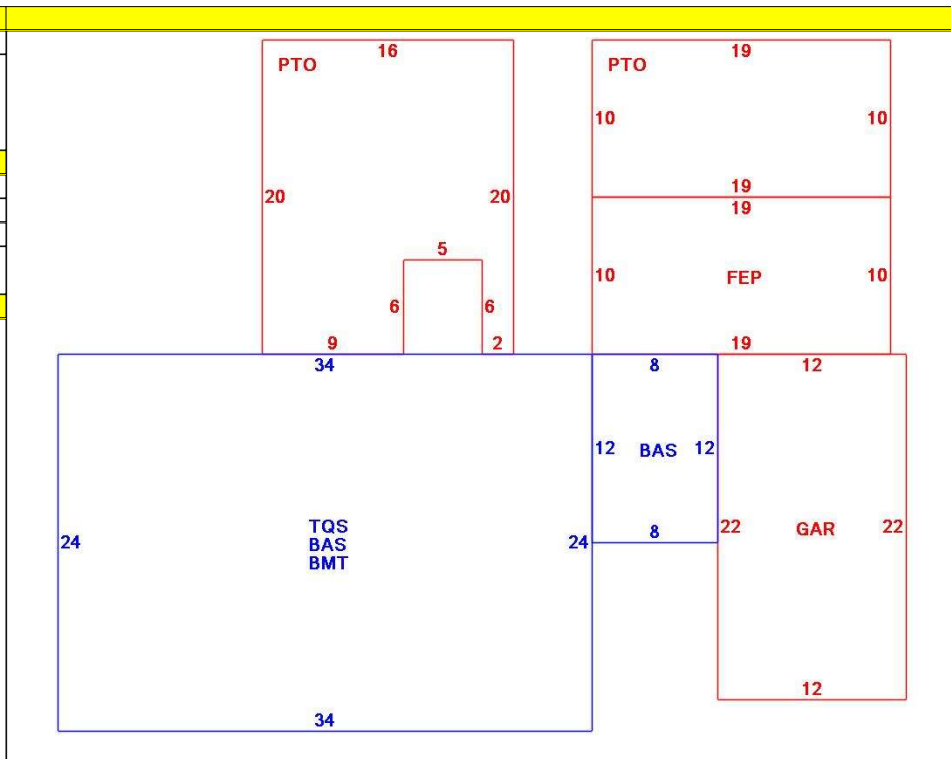

OB - OUTBUILDING & YARD ITEMS(L) / XF - BUILDING EXTRA FEATURES(B)										
Code	Description	L/B	Units	Unit Price	Yr Blt	Cond. Cd	% Gd	Grade	Grade Adj.	Appr. Value
FPL2	Fireplace 1.5 s	B	1	6000.00	1993		78		0.00	4,700
FEP	Enclosed porc	B	190	70.00	1993		78		0.00	9,500
GAR	Attached Gara	B	264	40.00	1993		78		0.00	9,500
BMT	Basement-Unfi	B	816	26.01	1993		78		0.00	17,900
PAT1	Patio- Average	L	190	5.89	2017		98		0.00	1,200
PATF	Flagstone Pav	L	290	30.00	2017		98		0.00	8,600
SHED	Shed	L	80	18.00	2019		100		0.00	1,400

BUILDING SUB-AREA SUMMARY SECTION						
Code	Description	Living Area	Floor Area	Eff Area	Unit Cost	Undeprec Value
BAS	First Floor	912	912	912	253.30	231,010
BMT	Basement Area	0	816	0	0.00	0
FEP	Enclosed Porch	0	190	0	0.00	0
GAR	Attached Garage	0	264	0	0.00	0
PTO	Patio	0	480	0	0.00	0
TQS	Three Quarter Story	530	816	530	164.52	134,249
Ttl Gross Liv / Lease Area		1,442	3,478	1,442		365,259

