

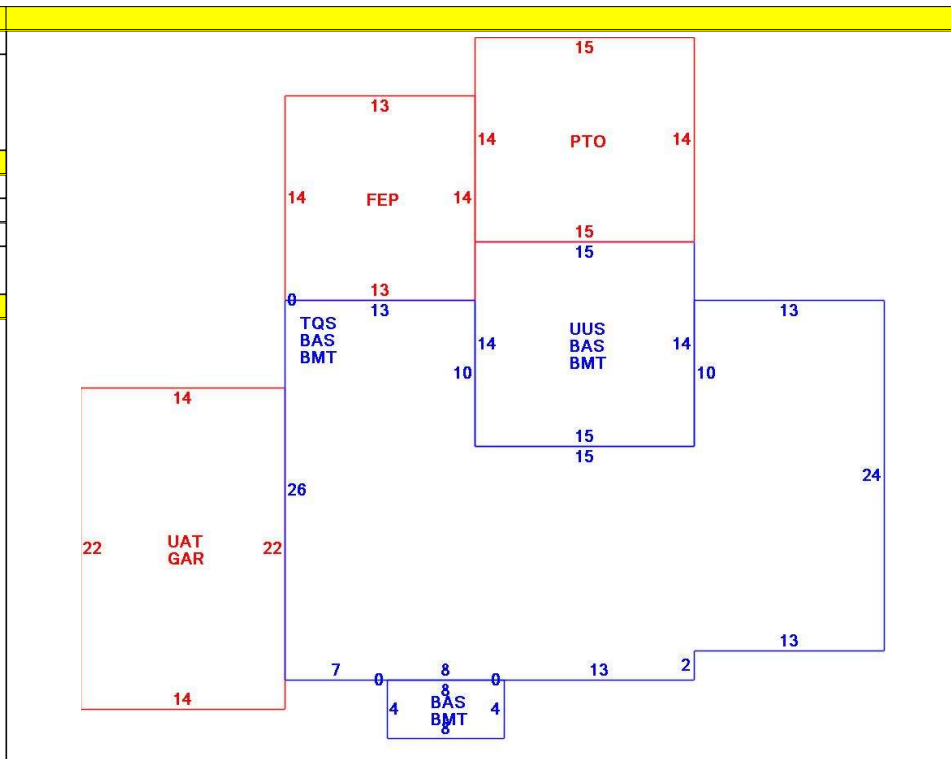

CONSTRUCTION DETAIL			CONSTRUCTION DETAIL (CONTINUED)		
Element	Cd	Description	Element	Cd	Description
Style	04	Cape Cod			
Model	01	Residential			
Grade:	C+	Average Plus			
Stories	1.75	1 3/4 Stories			
Exterior Wall 1	14	Wood Shingle			
Exterior Wall 2	11	Clapboard			
RooF Structure	03	Gable/Hip			
RooF Cover	03	Asph/F Gls/Cmp			
Interior Wall 1	03	Plastered			
Interior Wall 2					
Interior Floor 1	12	Hardwood			
Interior Floor 2					
Heat Fuel	04	Electric			
Heat Type	07	Elec Baseboard			
AC Type	03	Central			
Bedrooms	03	3 Bedrooms			
Full Baths	2				
Half Baths	1				
Extra Fixtures					
Total Rooms	6	6 Rooms			
Bath Style					
Kitchen Style					
Occupancy					
Usrflid 105					
Accessory Apt					
Foundation Alt	01	Poured Conc.			
Rms Prts					
Bath Split	21	2 Full-1 Half			
			<b>CONDO DATA</b>		
			Parcel Id	C	Ownr 0.0
				B	S
			Adjust Type	Code	Description
			Condo Flr		
			Condo Unit		
			<b>COST / MARKET VALUATION</b>		
			Building Value New		535,375
			Year Built		1999
			Effective Year Built		2005
			Depreciation Code		A
			Remodel Rating		
			Year Remodeled		
			Depreciation %		11
			Functional Obsol		0
			External Obsol		0
			Trend Factor		1
			Condition		
			Condition %		
			Percent Good		89
			RCNLD		476,500
			Dep % Ovr		
			Dep Ovr Comment		
			Misc Imp Ovr		
			Misc Imp Ovr Comment		
			Cost to Cure Ovr		
			Cost to Cure Ovr Comment		



OB - OUTBUILDING & YARD ITEMS(L) / XF - BUILDING EXTRA FEATURES(B)										
Code	Description	L/B	Units	Unit Price	Yr Blt	Cond. Cd	% Gd	Grade	Grade Adj.	Appr. Value
FPL2	Fireplace 1.5 s	B	1	6000.00	2007		89		0.00	5,300
PAT2	Patio-Good	L	210	9.94	2005		86		0.00	2,000
FEP	Enclosed porc	B	182	70.00	2007		89		0.00	10,600
GAR	Attached Gara	B	308	40.00	2007		89		0.00	12,100
BMT	Basement-Unfi	B	1,132	26.01	2007		89		0.00	25,700
BFA	Bsmt Fin-Avg	B	1,032	17.36	2007		89		0.00	15,900

BUILDING SUB-AREA SUMMARY SECTION						
Code	Description	Living Area	Floor Area	Eff Area	Unit Cost	Undeprec Value
BAS	First Floor	1,132	1,132	1,132	278.70	315,484
BMT	Basement Area	0	1,132	0	0.00	0
FEP	Enclosed Porch	0	182	0	0.00	0
GAR	Attached Garage	0	308	0	0.00	0
PTO	Patio	0	210	0	0.00	0
TQS	Three Quarter Story	579	890	579	181.31	161,365
UAT	Attic, Unfinished	0	308	31	28.05	8,640
UUS	Upper Story, Unfinished	0	210	179	237.56	49,887
Ttl Gross Liv / Lease Area		1,711	4,372	1,921		535,376

