

CURRENT OWNER		TOPO	UTILITIES	STRT / ROAD	LOCATION	CURRENT ASSESSMENT				801 FY2024 BARNSTABLE, MA
FARRELL, CYNTHIA A		1 Level	6 Septic	1 Paved		Description	Code	Assessed	Assessed	
31 DAYBREAK LN			4 Gas			RESIDNTL	1010	523,000	523,000	
HYANNIS MA 02601			2 Public Water			RES LAND	1010	146,700	146,700	
SUPPLEMENTAL DATA						Total				VISION
Alt Prcl ID		Split Zonin		Plan Ref. 425/32						
BID Parcel		ResExpt Q YES:		Land Ct#						
#DL 1 LOT 90		#DL 2		Life Estate						
GIS ID F_980456_2706349		Assoc Pid#		PP STATU						

RECORD OF OWNERSHIP		BK-VOL/PAGE	SALE DATE	Q/U	V/I	SALE PRIC	VC	PREVIOUS ASSESSMENTS (HISTORY)								
FARRELL, CYNTHIA A		11703 0122	09-16-1998	U	I	230,000	1P	Year	Code	Assessed	Year	Code	Assessed			
DACEY, BRIAN T TR		11096 0080	12-03-1997	U	V	1,969,000	1	2023	1010	467,900	2022	1010	391,200			
COBBLESTONE LANDING INC		9128 0054	04-01-1994	U	V	100	F		1010	133,300		1010	98,800			
FRANCO R E DEV CO, INC		7851 0158	01-28-1992	U	V	1	N					1010	4,100			
Total								601,200		Total		490,000		Total		434,700

EXEMPTIONS				OTHER ASSESSMENTS				This signature acknowledges a visit by a Data Collector or Assessor				
Year	Code	Description	Amount	Code	Description	Number	Amount	Comm Int				
2010	5C	RESIDENTIAL EXEMPTION	0.00									
Total			0.00									

ASSESSING NEIGHBORHOOD				APPRAISED VALUE SUMMARY			
Nbhd	Nbhd Name	B	Tracing	Batch			
0107				HYAN			

NOTES				APPRAISED VALUE SUMMARY			
				Appraised Bldg. Value (Card)	476,300		
				Appraised Xf (B) Value (Bldg)	42,600		
				Appraised Ob (B) Value (Bldg)	4,100		
				Appraised Land Value (Bldg)	146,700		
				Special Land Value	0		
				Total Appraised Parcel Value	669,700		
				Valuation Method	C		
				Total Appraised Parcel Value	669,700		

BUILDING PERMIT RECORD								VISIT / CHANGE HISTORY							
Permit Id	Issue Date	Type	Description	Amount	Insp Date	% Comp	Date Comp	Comments	Date	Id	Type	Is	Cd	Purpost/Result	
29172	03-02-1998	DW	Dwelling	96,800	07-26-2000	100	01-01-2000		04-28-2020	WD			FR	Field Review	
									12-06-2017	KM	02		03	Cycl Insp Comp	
									08-04-2014	JR	03		16	In Office Review	
									10-13-2011	RB	03		16	In Office Review	
									07-26-2000	MF	01		00	Meas/Listed-Interior Acces	

LAND LINE VALUATION SECTION																
B	Use Code	Description	Zone	LA	Land Units	Unit Price	Size Adj	AC Disc	Site Index	Cond.	Nbhd.	Nbhd. Adj	Notes	Location Adjustmen	Adj Unit P	Land Value
1	1010	Single Fam M-0	RC-	4	0.230 AC	176,344.00	3.61599	1.0000	5	1.00	0105	1.000		1.0000	637,659.9	146,700
Total Card Land Units					0.23	AC	Parcel Total Land Area					0.23	Total Land Value			146,700

CONSTRUCTION DETAIL			CONSTRUCTION DETAIL (CONTINUED)		
Element	Cd	Description	Element	Cd	Description
Style	04	Cape Cod			
Model	01	Residential			
Grade:	C+	Average Plus			
Stories	1.75	1 3/4 Stories			
Exterior Wall 1	14	Wood Shingle			
Exterior Wall 2					
RooF Structure	03	Gable/Hip			
RooF Cover	03	Asph/F Gls/Cmp			
Interior Wall 1	03	Plastered			
Interior Wall 2					
Interior Floor 1	12	Hardwood			
Interior Floor 2					
Heat Fuel	03	Gas			
Heat Type	04	Hot Air			
AC Type	03	Central			
Bedrooms	03	3 Bedrooms			
Full Baths	2				
Half Baths	1				
Extra Fixtures					
Total Rooms	6	6 Rooms			
Bath Style					
Kitchen Style					
Occupancy					
Usrflid 105					
Accessory Apt					
Foundation Alt	01	Poured Conc.			
Rms Prts					
Bath Split	21	2 Full-1 Half			

CONDO DATA				
Parcel Id		C		Ownr 0.0
			B	S
Adjust Type	Code	Description	Factor%	
Condo Flr				
Condo Unit				

COST / MARKET VALUATION		
Building Value New		535,139
Year Built		1999
Effective Year Built		2005
Depreciation Code		A
Remodel Rating		
Year Remodeled		
Depreciation %		11
Functional Obsol		0
External Obsol		0
Trend Factor		1
Condition		
Condition %		
Percent Good		89
RCNLD		476,300
Dep % Ovr		
Dep Ovr Comment		
Misc Imp Ovr		
Misc Imp Ovr Comment		
Cost to Cure Ovr		
Cost to Cure Ovr Comment		

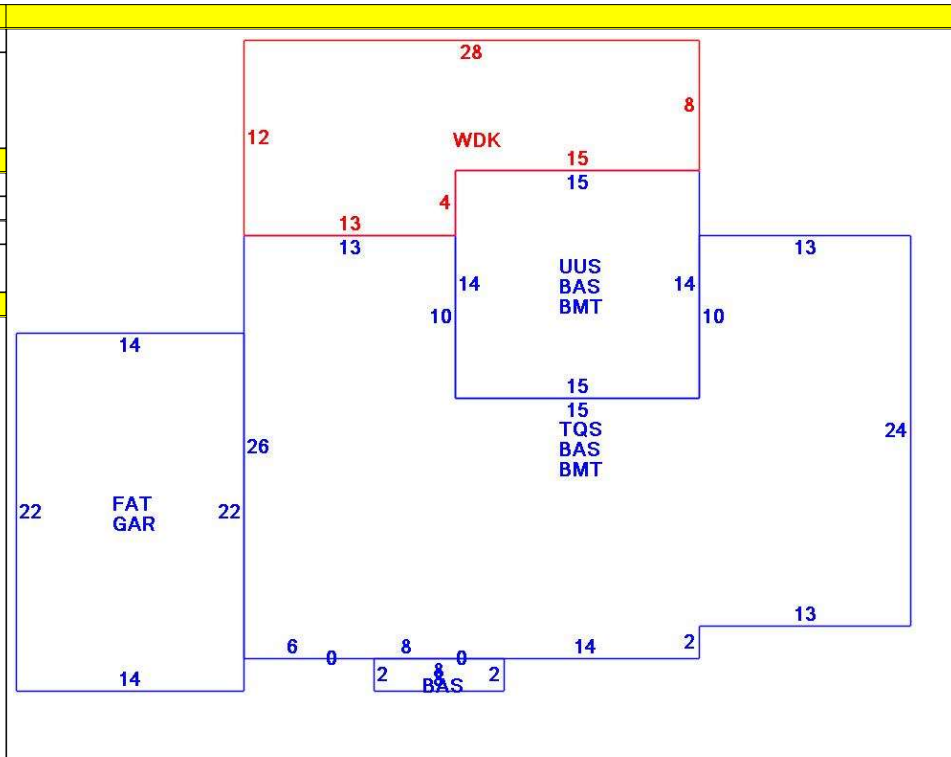

OB - OUTBUILDING & YARD ITEMS(L) / XF - BUILDING EXTRA FEATURES(B)										
Code	Description	L/B	Units	Unit Price	Yr Blt	Cond. Cd	% Gd	Grade	Grade Adj.	Appr. Value
FPL2	Fireplace 1.5 s	B	1	6000.00	2007		89		0.00	5,300
WDC	Wood Decking	L	276	20.00	2005		72		0.00	4,100
GAR	Attached Gara	B	308	40.00	2007		89		0.00	12,100
BMT	Basement-Unfi	B	1,100	26.01	2007		89		0.00	25,200

BUILDING SUB-AREA SUMMARY SECTION						
Code	Description	Living Area	Floor Area	Eff Area	Unit Cost	Undeprec Value
BAS	First Floor	1,116	1,116	1,116	278.72	311,049
BMT	Basement Area	0	1,100	0	0.00	0
FAT	Attic, Finished	46	308	46	41.63	12,821
GAR	Attached Garage	0	308	0	0.00	0
TQS	Three Quarter Story	579	890	579	181.32	161,378
UUS	Upper Story, Unfinished	0	210	179	237.57	49,891
WDC	Wood Deck	0	276	0	0.00	0
Ttl Gross Liv / Lease Area		1,741	4,208	1,920		535,139

