

CONSTRUCTION DETAIL			CONSTRUCTION DETAIL (CONTINUED)		
Element	Cd	Description	Element	Cd	Description
Style	01	Ranch			
Model	01	Residential			
Grade:	C	Average			
Stories	1	1 Story			
Exterior Wall 1	14	Wood Shingle			
Exterior Wall 2	11	Clapboard			
Roof Structure	03	Gable/Hip			
Roof Cover	03	Asph/F Gls/Cmp			
Interior Wall 1	05	Drywall			
Interior Wall 2					
Interior Floor 1	12	Hardwood			
Interior Floor 2					
Heat Fuel	03	Gas			
Heat Type	04	Hot Air			
AC Type	03	Central			
Bedrooms	02	2 Bedrooms			
Full Baths	1				
Half Baths	0				
Extra Fixtures					
Total Rooms	4	4 Rooms			
Bath Style					
Kitchen Style					
Occupancy					
Usrflid 105					
Accessory Apt					
Foundation Alt	01	Poured Conc.			
Rms Prts					
Bath Split	10	1 Full-0 Half			

CONDO DATA				
Parcel Id		C	Owne	0.0
Adjust Type	Code	Description	Factor%	
Condo Flr				
Condo Unit				

COST / MARKET VALUATION		
Building Value New		414,053
Year Built		1964
Effective Year Built		1993
Depreciation Code		G
Remodel Rating		
Year Remodeled		
Depreciation %		20
Functional Obsol		0
External Obsol		0
Trend Factor		1
Condition		
Condition %		
Percent Good		80
RCNLD		331,200
Dep % Ovr		
Dep Ovr Comment		
Misc Imp Ovr		
Misc Imp Ovr Comment		
Cost to Cure Ovr		
Cost to Cure Ovr Comment		

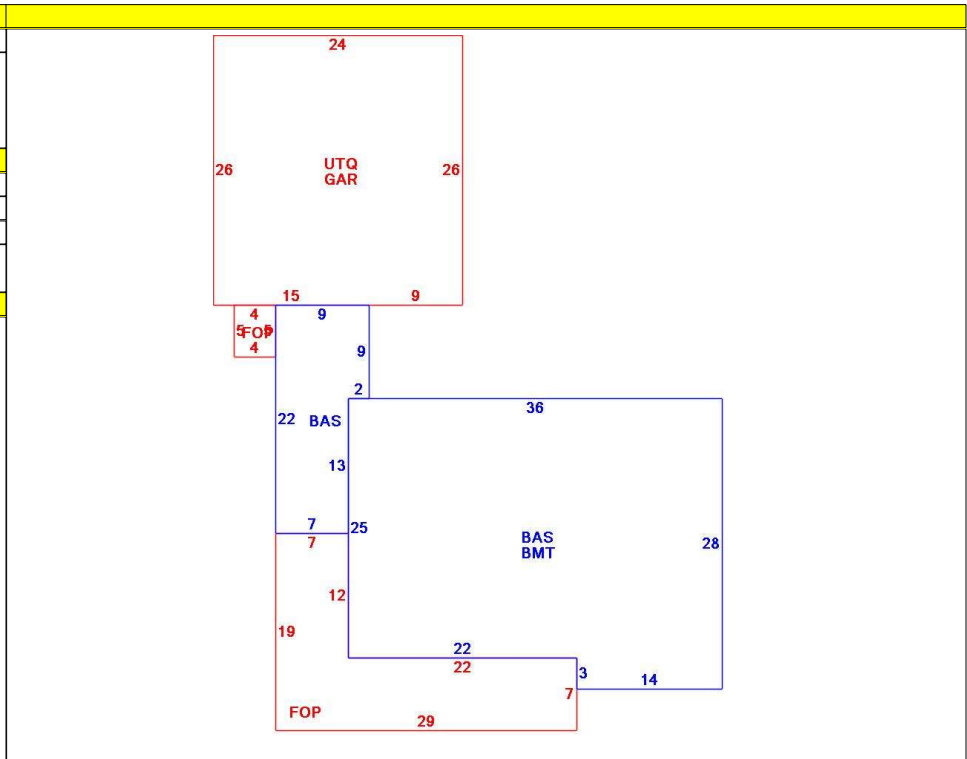

OB - OUTBUILDING & YARD ITEMS(L) / XF - BUILDING EXTRA FEATURES(B)										
Code	Description	L/B	Units	Unit Price	Yr Blt	Cond. Cd	% Gd	Grade	Grade Adj.	Appr. Value
FPL1	Fireplace 1 sto	B	1	5000.00	1995		80		0.00	4,000
FOP	Open Porch-ro	B	287	55.00	1995		80		0.00	9,100
GAR	Attached Gara	B	624	40.00	1995		80		0.00	17,300
BMT	Basement-Unfi	B	942	26.01	1995		80		0.00	20,400
FPLG	Gas Fireplace-	B	1	2500.00	1995		80		0.00	2,000

BUILDING SUB-AREA SUMMARY SECTION						
Code	Description	Living Area	Floor Area	Eff Area	Unit Cost	Undeprec Value
BAS	First Floor	1,114	1,114	1,114	290.36	323,461
BMT	Basement Area	0	942	0	0.00	0
FOP	Open Porch	0	307	0	0.00	0
GAR	Attached Garage	0	624	0	0.00	0
UTQ	Unfinished Three-quarter story	0	624	312	145.18	90,592
Ttl Gross Liv / Lease Area		1,114	3,611	1,426		414,053

