

CURRENT OWNER		TOPO	UTILITIES	STRT / ROAD	LOCATION	CURRENT ASSESSMENT				801 FY2024 BARNSTABLE, MA VISION
SHEEHY, NANCY M 50 CASTLEWOOD CIRCLE HYANNIS MA 02601		1 Level	2 Public Water	1 Paved		Description	Code	Assessed	Assessed	
			4 Gas			RESIDNTL	1010	278,100	278,100	
			6 Septic			RES LAND	1010	140,800	140,800	
SUPPLEMENTAL DATA						Total				418,900
Alt Prcl ID		Split Zonin		Plan Ref.						
50 CASTLEWOOD CIRCLE		#DL 1 LOT 20		Land Ct# 24349-B (SH 2)						
#DL 2		GIS ID F_981720_2707378		Assoc Pid#						

RECORD OF OWNERSHIP		BK-VOL/PAGE	SALE DATE	Q/U	V/I	SALE PRIC	VC	PREVIOUS ASSESSMENTS (HISTORY)							
SHEEHY, NANCY M	C205153	0	12-10-2014	U	I	100	1F	Year	Code	Assessed	Year	Code	Assessed		
BLACK ROCK PROPERTIES LLC	C192555	0	09-30-2010	U	I	1	1F	2023	1010	239,800	2022	1010	207,500		
SHEEHY, NANCY MARIE	C147294	0	01-26-1998	U	I	98,000	1A		1010	128,000		1010	94,800		
SHEEHY, CHARLES M & MARY ANN	C144006	0	03-31-1997	Q	I	88,000	00					1010	700		
MARIANO, JOSEPH & NANCY	C110590	0	04-15-1987	Q	I	110,000	U								
Total										367,800			302,300	Total	266,100

EXEMPTIONS			OTHER ASSESSMENTS					
Year	Code	Description	Amount	Code	Description	Number	Amount	Comm Int
Total			0.00					

ASSESSING NEIGHBORHOOD			
Nbhd	Nbhd Name	B	Tracing
0105			Batch HYAN

NOTES			
This signature acknowledges a visit by a Data Collector or Assessor			
APPRAISED VALUE SUMMARY			
Appraised Bldg. Value (Card)			240,700
Appraised Xf (B) Value (Bldg)			36,700
Appraised Ob (B) Value (Bldg)			700
Appraised Land Value (Bldg)			140,800
Special Land Value			0
Total Appraised Parcel Value			418,900
Valuation Method			C
Total Appraised Parcel Value			418,900

BUILDING PERMIT RECORD							VISIT / CHANGE HISTORY							
Permit Id	Issue Date	Type	Description	Amount	Insp Date	% Comp	Date Comp	Comments	Date	Id	Type	Is	Cd	Purpost/Result
									04-27-2020	WD			FR	Field Review
									01-10-2017	KM	02		03	Cycl Insp Comp
									08-18-2015	TP	03		16	In Office Review
									01-24-2001	PT	01		00	Meas/Listed-Interior Acces

LAND LINE VALUATION SECTION																
B	Use Code	Description	Zone	LA	Land Units	Unit Price	Size Adj	AC Disc	Site Index	Cond.	Nbhd.	Nbhd. Adj	Notes	Location Adjustmen	Adj Unit P	Land Value
1	1010	Single Fam M-0	RC-	4	0.180 AC	176,344.00	4.43465	1.0000	5	1.00	0105	1.000		1.0000	782,032.7	140,800
Total Card Land Units					0.18	AC	Parcel Total Land Area					0.18	Total Land Value			140,800

CONSTRUCTION DETAIL			CONSTRUCTION DETAIL (CONTINUED)		
Element	Cd	Description	Element	Cd	Description
Style	01	Ranch			
Model	01	Residential			
Grade:	C	Average			
Stories	1	1 Story			
Exterior Wall 1	14	Wood Shingle			
Exterior Wall 2	11	Clapboard			
RooF Structure	03	Gable/Hip			
RooF Cover	03	Asph/F Gls/Cmp			
Interior Wall 1	05	Drywall			
Interior Wall 2					
Interior Floor 1	14	Carpet			
Interior Floor 2					
Heat Fuel	03	Gas			
Heat Type	04	Hot Air			
AC Type	01	None			
Bedrooms	02	2 Bedrooms			
Full Baths	1				
Half Baths	0				
Extra Fixtures					
Total Rooms	5	5 Rooms			
Bath Style					
Kitchen Style					
Occupancy					
Usrflid 105					
Accessory Apt					
Foundation Alt	01	Poured Conc.			
Rms Prts					
Bath Split	10	1 Full-0 Half			

CONDO DATA			
Parcel Id		C	Ownr 0.0
Adjust Type	Code	Description	Factor%
Condo Flr			
Condo Unit			

COST / MARKET VALUATION		
Building Value New		312,547
Year Built		1966
Effective Year Built		1989
Depreciation Code		A
Remodel Rating		
Year Remodeled		
Depreciation %		23
Functional Obsol		0
External Obsol		0
Trend Factor		1
Condition		
Condition %		
Percent Good		77
RCNLD		240,700
Dep % Ovr		
Dep Ovr Comment		
Misc Imp Ovr		
Misc Imp Ovr Comment		
Cost to Cure Ovr		
Cost to Cure Ovr Comment		

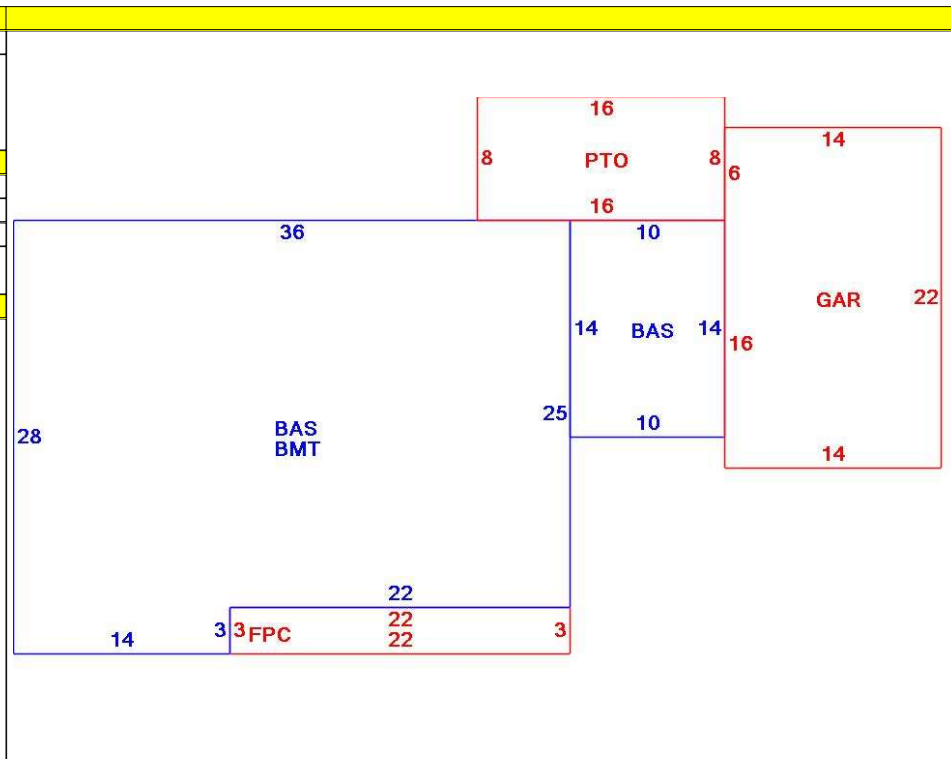

OB - OUTBUILDING & YARD ITEMS(L) / XF - BUILDING EXTRA FEATURES(B)										
Code	Description	L/B	Units	Unit Price	Yr Blt	Cond. Cd	% Gd	Grade	Grade Adj.	Appr. Value
FPL1	Fireplace 1 sto	B	1	5000.00	1991		77		0.00	3,900
PAT1	Patio- Average	L	128	5.89	1994		75		0.00	700
FOPC	Open Prch-roo	B	66	55.00	1991		77		0.00	2,700
GAR	Attached Gara	B	308	40.00	1991		77		0.00	10,500
BMT	Basement-Unfi	B	942	26.01	1991		77		0.00	19,600

BUILDING SUB-AREA SUMMARY SECTION						
Code	Description	Living Area	Floor Area	Eff Area	Unit Cost	Undeprec Value
BAS	First Floor	1,082	1,082	1,082	288.86	312,547
BMT	Basement Area	0	942	0	0.00	0
FPC	Open Porch Conc. Floor	0	66	0	0.00	0
GAR	Attached Garage	0	308	0	0.00	0
PTO	Patio	0	128	0	0.00	0
Ttl Gross Liv / Lease Area		1,082	2,526	1,082		312,547

