

| CURRENT OWNER | | TOPO | UTILITIES | STRT / ROAD | LOCATION | CURRENT ASSESSMENT | | | | 801 FY2024 BARNSTABLE, MA VISION | |
|---|--|---------|----------------|--|----------|--------------------|------|----------|----------|--|---------|
| HASKELL, BENJAMIN B & MARGARE 690 OLD STRAWBERRY HILL RD CENTERVILLE MA 02632 | | 1 Level | 2 Public Water | 1 Paved | | Description | Code | Assessed | Assessed | | |
| | | | 4 Gas | | | RESIDNTL | 1010 | 459,900 | 459,900 | | |
| | | | 6 Septic | | | RES LAND | 1010 | 176,400 | 176,400 | | |
| SUPPLEMENTAL DATA | | | | | | Total | | | | 636,300 | 636,300 |
| Alt Prcl ID Split Zonin BID Parcel ResExpt Q YES: #DL 1 LOT 4 #DL 2 GIS ID F_979579_2708342 | | | | Plan Ref. 350/44 Land Ct# #SR Life Estate PP STATU Assoc Pid# | | | | | | | |

| RECORD OF OWNERSHIP | | BK-VOL/PAGE | SALE DATE | Q/U | V/I | SALE PRIC | VC | PREVIOUS ASSESSMENTS (HISTORY) | | | | | | | |
|--|-------|-------------|------------|-----|-----|-----------|----|--------------------------------|------|----------|-------|------|----------|-------|---------|
| HASKELL, BENJAMIN B & MARGARET E | 23679 | 0150 | 05-07-2009 | Q | I | 345,000 | 00 | Year | Code | Assessed | Year | Code | Assessed | | |
| FACCHETTI, FRANCIS A JR & ANNE M | 20180 | 0182 | 08-22-2005 | U | I | 0 | 1A | 2023 | 1010 | 392,500 | 2022 | 1010 | 324,700 | | |
| GRAHAM, ANNE MARIE | 16853 | 0338 | 05-02-2003 | U | I | 0 | 1 | | 1010 | 160,400 | | 1010 | 118,900 | | |
| GRAHAM, GARY CHRISTOPHER & RAPOSO, GIL | 5796 | 0286 | 06-15-1987 | Q | V | 62,000 | U | | | | | 1010 | 11,800 | | |
| | 5283 | 0149 | 09-15-1986 | Q | V | 45,000 | U | Total | | 552,900 | Total | | 443,600 | Total | 416,800 |

| EXEMPTIONS | | | | OTHER ASSESSMENTS | | | | This signature acknowledges a visit by a Data Collector or Assessor | | | | | |
|------------|------|-----------------------|--------|-------------------|-------------|--------|--------|---|-----|--|--|--|--|
| Year | Code | Description | Amount | Code | Description | Number | Amount | Comm | Int | | | | |
| 2013 | 5C | RESIDENTIAL EXEMPTION | 0.00 | | | | | | | | | | |
| Total | | | 0.00 | | | | | | | | | | |

| ASSESSING NEIGHBORHOOD | | | | APPRAISED VALUE SUMMARY | | | | |
|------------------------|-----------|---|---------|-------------------------|-------------------------------|---------|--|--|
| Nbhd | Nbhd Name | B | Tracing | Batch | | | | |
| 0105 | | | | HYAN | Appraised Bldg. Value (Card) | 416,300 | | |
| | | | | | Appraised Xf (B) Value (Bldg) | 31,800 | | |
| | | | | | Appraised Ob (B) Value (Bldg) | 11,800 | | |
| | | | | | Appraised Land Value (Bldg) | 176,400 | | |
| | | | | | Special Land Value | 0 | | |
| | | | | | Total Appraised Parcel Value | 636,300 | | |
| | | | | | Valuation Method | C | | |
| | | | | | Total Appraised Parcel Value | 636,300 | | |

| NOTES | | | | | | | | | | VISIT / CHANGE HISTORY | | | | | |
|-------|--|--|--|--|--|--|--|--|--|------------------------|----|------|----|----|----------------------------|
| | | | | | | | | | | Date | Id | Type | Is | Cd | Purpost/Result |
| | | | | | | | | | | 04-28-2020 | WD | | | FR | Field Review |
| | | | | | | | | | | 08-19-2019 | SR | 01 | | 03 | Cycl Insp Comp |
| | | | | | | | | | | 03-15-2013 | GC | 03 | | 16 | In Office Review |
| | | | | | | | | | | 06-03-2009 | MA | 22 | | 22 | Change of Address |
| | | | | | | | | | | 05-21-2009 | NF | 03 | | 16 | In Office Review |
| | | | | | | | | | | 05-20-2009 | TR | 03 | | 16 | In Office Review |
| | | | | | | | | | | 10-05-2000 | PT | 01 | | 00 | Meas/Listed-Interior Acces |

| BUILDING PERMIT RECORD | | | | | | | | | | LAND LINE VALUATION SECTION | | | | | |
|------------------------|------------|------|----------------|--------|------------|--------|-----------|----------------------------------|--|-----------------------------|----|------|----|----|------------------|
| Permit Id | Issue Date | Type | Description | Amount | Insp Date | % Comp | Date Comp | Comments | | Date | Id | Type | Is | Cd | Purpost/Result |
| EXPR-23-1 | 10-31-2023 | 835 | Sid/Wind/Roof/ | 2,000 | | 100 | | RESIDENTIAL WEATHERIZA | | 04-28-2020 | WD | | | FR | Field Review |
| BLDR-23-11 | 02-06-2023 | 839 | Solar Panel-Re | 13,931 | | 0 | | Installation of a interconnected | | 08-19-2019 | SR | 01 | | 03 | Cycl Insp Comp |
| B31102 | 08-01-1987 | DW | Dwelling | 65,000 | 02-15-1989 | 100 | | CE 11/2 S | | 03-15-2013 | GC | 03 | | 16 | In Office Review |

| B | Use Code | Description | Zone | LA | Land Units | Unit Price | Size Adj | AC Disc | Site Index | Cond. | Nbhd. | Nbhd. Adj | Notes | Location Adjustmen | Adj Unit P | Land Value |
|-----------------------|----------|----------------|------|----|------------|---------------|------------------------|---------|------------|-------|-------|-----------|------------------|--------------------|------------|------------|
| 1 | 1010 | Single Fam M-0 | RC- | 4 | 1.000 | AC 176,344.00 | 1.00000 | 1.0000 | 5 | 1.00 | 0105 | 1.000 | | 1.0000 | 176,344 | 176,300 |
| 1 | 1010 | Single Fam M-0 | RC- | 4 | 0.010 | AC 14,250.00 | 1.00000 | 1.0000 | 0 | 1.00 | 0105 | 1.000 | | 1.0000 | 14,250 | 100 |
| Total Card Land Units | | | | | 1.01 | AC | Parcel Total Land Area | | | | | 1.01 | Total Land Value | | | 176,400 |

| CONSTRUCTION DETAIL | | | CONSTRUCTION DETAIL (CONTINUED) | | |
|---------------------|----|----------------|---------------------------------|----|-------------|
| Element | Cd | Description | Element | Cd | Description |
| Style | 03 | Colonial | | | |
| Model | 01 | Residential | | | |
| Grade: | C | Average | | | |
| Stories | 2 | 2 Stories | | | |
| Exterior Wall 1 | 11 | Clapboard | | | |
| Exterior Wall 2 | | | | | |
| RooF Structure | 03 | Gable/Hip | | | |
| RooF Cover | 03 | Asph/F Gls/Cmp | | | |
| Interior Wall 1 | 05 | Drywall | | | |
| Interior Wall 2 | | | | | |
| Interior Floor 1 | 14 | Carpet | | | |
| Interior Floor 2 | 12 | Hardwood | | | |
| Heat Fuel | 03 | Gas | | | |
| Heat Type | 05 | Hot Water | | | |
| AC Type | 01 | None | | | |
| Bedrooms | 03 | 3 Bedrooms | | | |
| Full Baths | 2 | | | | |
| Half Baths | 1 | | | | |
| Extra Fixtures | | | | | |
| Total Rooms | 8 | 8 Rooms | | | |
| Bath Style | | | | | |
| Kitchen Style | | | | | |
| Occupancy | | | | | |
| Usrflid 105 | | | | | |
| Accessory Apt | | | | | |
| Foundation Alt | 01 | Poured Conc. | | | |
| Rms Prts | | | | | |
| Bath Split | 21 | 2 Full-1 Half | | | |

| CONDO DATA | | | | |
|-------------|------|-------------|---------|----------|
| Parcel Id | C | B | S | Owne 0.0 |
| | | | | |
| Adjust Type | Code | Description | Factor% | |
| Condo Flr | | | | |
| Condo Unit | | | | |

| COST / MARKET VALUATION | | |
|--------------------------|--|---------|
| Building Value New | | 489,742 |
| Year Built | | 1988 |
| Effective Year Built | | 2000 |
| Depreciation Code | | A |
| Remodel Rating | | |
| Year Remodeled | | |
| Depreciation % | | 15 |
| Functional Obsol | | 0 |
| External Obsol | | 0 |
| Trend Factor | | 1 |
| Condition | | |
| Condition % | | |
| Percent Good | | 85 |
| RCNLD | | 416,300 |
| Dep % Ovr | | |
| Dep Ovr Comment | | |
| Misc Imp Ovr | | |
| Misc Imp Ovr Comment | | |
| Cost to Cure Ovr | | |
| Cost to Cure Ovr Comment | | |

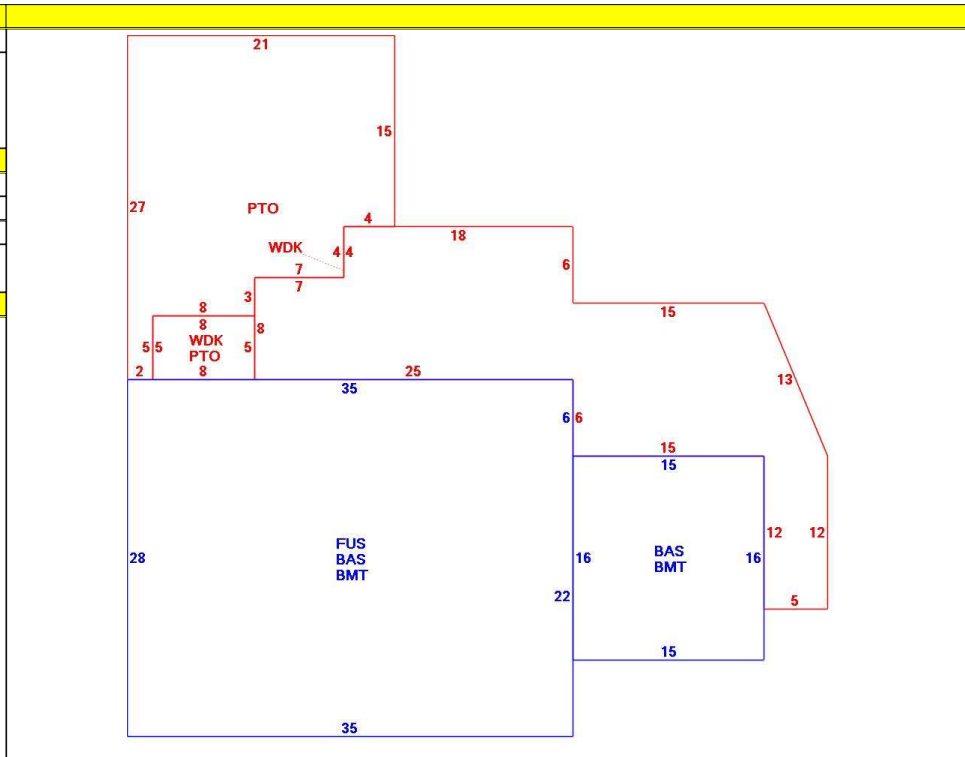

| OB - OUTBUILDING & YARD ITEMS(L) / XF - BUILDING EXTRA FEATURES(B) | | | | | | | | | | |
|--|-----------------|-----|-------|------------|--------|----------|------|-------|------------|-------------|
| Code | Description | L/B | Units | Unit Price | Yr Blt | Cond. Cd | % Gd | Grade | Grade Adj. | Appr. Value |
| FPL3 | Fireplace 2 sto | B | 1 | 7000.00 | 2002 | | 85 | | 0.00 | 6,000 |
| WDC | Wood Decking | L | 582 | 20.00 | 2000 | | 62 | | 0.00 | 6,700 |
| BMT | Basement-Unfi | B | 1,220 | 26.01 | 2002 | | 85 | | 0.00 | 25,800 |
| SHED | Shed | L | 96 | 18.00 | 1990 | | 42 | | 0.00 | 700 |
| PAT2 | Patio-Good | L | 463 | 9.94 | 2018 | | 99 | | 0.00 | 4,400 |

| BUILDING SUB-AREA SUMMARY SECTION | | | | | | |
|-----------------------------------|---------------|-------------|------------|----------|-----------|----------------|
| Code | Description | Living Area | Floor Area | Eff Area | Unit Cost | Undeprec Value |
| BAS | First Floor | 1,220 | 1,220 | 1,220 | 222.61 | 271,584 |
| BMT | Basement Area | 0 | 1,220 | 0 | 0.00 | 0 |
| FUS | Upper Story | 980 | 980 | 980 | 222.61 | 218,158 |
| PTO | Patio | 0 | 463 | 0 | 0.00 | 0 |
| WDK | Wood Deck | 0 | 582 | 0 | 0.00 | 0 |
| Ttl Gross Liv / Lease Area | | 2,200 | 4,465 | 2,200 | | 489,742 |

