

CURRENT OWNER		TOPO	UTILITIES	STRT / ROAD	LOCATION	CURRENT ASSESSMENT				
MONIZ, JOHN B JR & CLARE D TRS MONIZ FAMILY TRUST 91 DAYBREAK LANE						Description	Code	Assessed	Assessed	801 FY2024 BARNSTABLE, MA
HYANNIS MA 02601						RESIDNTL	1010	521,900	521,900	
SUPPLEMENTAL DATA						RES LAND	1010	143,200	143,200	VISION
Alt Prcl ID Split Zonin BID Parcel ResExpt Q #DL 1 LOT 94 #DL 2 GIS ID F_980640_2706807				Plan Ref. 425/31 Land Ct# #SR Life Estate PP STATU Assoc Pid#		Total		665,100	665,100	

RECORD OF OWNERSHIP		BK-VOL/PAGE	SALE DATE	Q/U	V/I	SALE PRIC	VC	PREVIOUS ASSESSMENTS (HISTORY)								
MONIZ, JOHN B JR & CLARE D TRS		24079 0094	10-06-2009	U	I	1	1F	Year	Code	Assessed	Year	Code	Assessed	Year	Code	Assessed
MONIZ, JOHN B & CLARE D		12914 0330	03-30-2000	U	I	259,000	1	2023	1010	467,700	2022	1010	392,100	2021	1010	332,000
DACEY, BRIAN T TR		11096 0080	12-03-1997	U	V	1,969,000	1		1010	130,200		1010	96,400		1010	96,400
COBBLESTONE LANDING INC		9128 0054	04-01-1994	U	V	100	F								1010	5,600
FRANCO R E DEV CO, INC		7851 0158	01-28-1992	U	V	100	N	Total		597,900	Total		488,500	Total		434,000

EXEMPTIONS				OTHER ASSESSMENTS				This signature acknowledges a visit by a Data Collector or Assessor								
Year	Code	Description	Amount	Code	Description	Number	Amount	Comm Int								
Total			0.00													

ASSESSING NEIGHBORHOOD				APPRAISED VALUE SUMMARY			
Nbhd	Nbhd Name	B	Tracing	Batch			
0107				HYAN	Appraised Bldg. Value (Card)	469,700	
					Appraised Xf (B) Value (Bldg)	46,600	
					Appraised Ob (B) Value (Bldg)	5,600	
					Appraised Land Value (Bldg)	143,200	
					Special Land Value	0	
					Total Appraised Parcel Value	665,100	
					Valuation Method	C	
					Total Appraised Parcel Value	665,100	

NOTES								VISIT / CHANGE HISTORY												
								Date	Id	Type	Is	Cd	Purpost/Result							
41089								09-15-1999	DW	Dwelling	110,360	08-15-2000	100	03-28-2000		04-28-2020	WD		FR	Field Review
															03-21-2017	KM	02	03	Cycl Insp Comp	
															06-13-2014	JR	03	16	In Office Review	
															02-14-2012	TR	03	16	In Office Review	
															10-15-2009	DR	03	16	In Office Review	
															08-15-2000	MF	02	05	Measur/New UC Under C	

BUILDING PERMIT RECORD												LAND LINE VALUATION SECTION				
Permit Id	Issue Date	Type	Description	Amount	Insp Date	% Comp	Date Comp	Comments								
41089	09-15-1999	DW	Dwelling	110,360	08-15-2000	100	03-28-2000									

B	Use Code	Description	Zone	LA	Land Units	Unit Price	Size Adj	AC Disc	Site Index	Cond.	Nbhd.	Nbhd. Adj	Notes	Location Adjustmen	Adj Unit P	Land Value
1	1010	Single Fam M-0	RC-	4	0.200 AC	176,344.00	4.05999	1.0000	5	1.00	0105	1.000		1.0000	715,956.6	143,200
Total Card Land Units					0.20	AC	Parcel Total Land Area					0.20	Total Land Value			143,200

CONSTRUCTION DETAIL			CONSTRUCTION DETAIL (CONTINUED)		
Element	Cd	Description	Element	Cd	Description
Style	04	Cape Cod			
Model	01	Residential			
Grade:	C+	Average Plus			
Stories	1.75	1 3/4 Stories			
Exterior Wall 1	14	Wood Shingle			
Exterior Wall 2	11	Clapboard			
RooF Structure	03	Gable/Hip			
RooF Cover	03	Asph/F Gls/Cmp			
Interior Wall 1	05	Drywall			
Interior Wall 2					
Interior Floor 1	12	Hardwood			
Interior Floor 2	14	Carpet			
Heat Fuel	03	Gas			
Heat Type	04	Hot Air			
AC Type	03	Central			
Bedrooms	03	3 Bedrooms			
Full Baths	2				
Half Baths	1				
Extra Fixtures					
Total Rooms	6	6 Rooms			
Bath Style					
Kitchen Style					
Occupancy					
Usrflid 105					
Accessory Apt					
Foundation Alt	01	Poured Conc.			
Rms Prts					
Bath Split	21	2 Full-1 Half			

CONDO DATA				
Parcel Id		C	Owne	0.0
Adjust Type	Code	Description	Factor%	
Condo Flr				
Condo Unit				

COST / MARKET VALUATION	
Building Value New	527,788
Year Built	1999
Effective Year Built	2005
Depreciation Code	A
Remodel Rating	
Year Remodeled	
Depreciation %	11
Functional Obsol	0
External Obsol	0
Trend Factor	1
Condition	
Condition %	
Percent Good	89
RCNLD	469,700
Dep % Ovr	
Dep Ovr Comment	
Misc Imp Ovr	
Misc Imp Ovr Comment	
Cost to Cure Ovr	
Cost to Cure Ovr Comment	

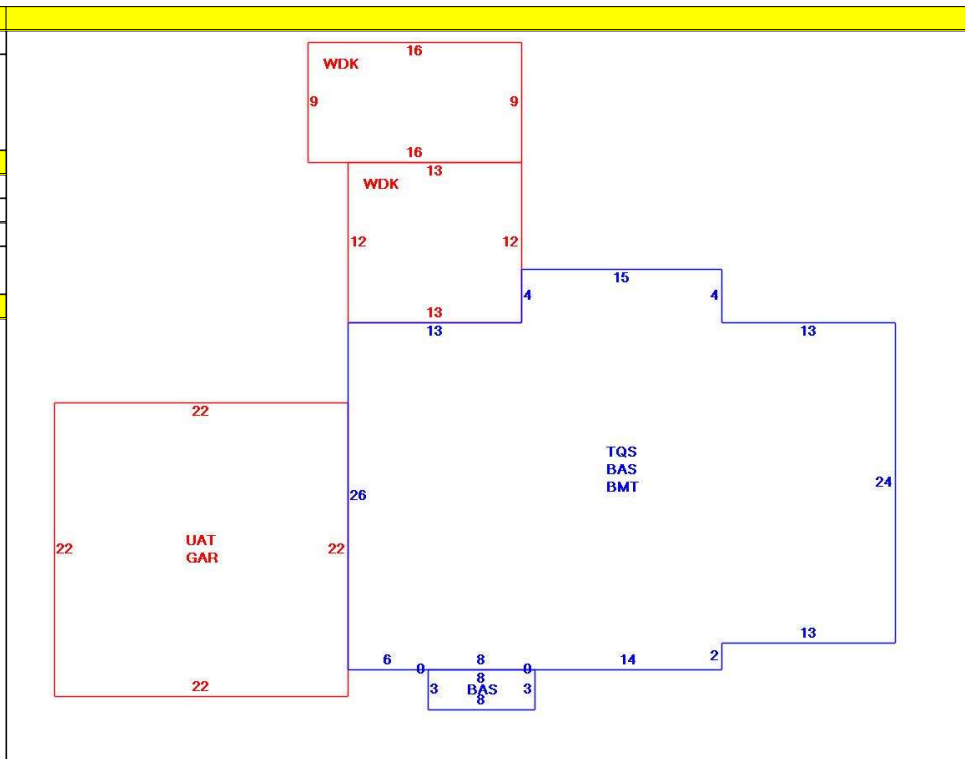

OB - OUTBUILDING & YARD ITEMS(L) / XF - BUILDING EXTRA FEATURES(B)										
Code	Description	L/B	Units	Unit Price	Yr Blt	Cond. Cd	% Gd	Grade	Grade Adj.	Appr. Value
FPL2	Fireplace 1.5 s	B	1	6000.00	2007		89		0.00	5,300
WDC	Wood Decking	L	156	20.00	2005		72		0.00	3,000
GAR	Attached Gara	B	484	40.00	2007		89		0.00	16,100
BMT	Basement-Unfi	B	1,100	26.01	2007		89		0.00	25,200
WDC	Wood Deck w/	L	144	18.00	2005		72		0.00	2,600

BUILDING SUB-AREA SUMMARY SECTION						
Code	Description	Living Area	Floor Area	Eff Area	Unit Cost	Undeprec Value
BAS	First Floor	1,124	1,124	1,124	279.70	314,379
BMT	Basement Area	0	1,100	0	0.00	0
GAR	Attached Garage	0	484	0	0.00	0
TQS	Three Quarter Story	715	1,100	715	181.80	199,983
UAT	Attic, Unfinished	0	484	48	27.74	13,425
WDK	Wood Deck	0	300	0	0.00	0
Ttl Gross Liv / Lease Area		1,839	4,592	1,887		527,787

