

CURRENT OWNER		TOPO	UTILITIES	STRT / ROAD	LOCATION	CURRENT ASSESSMENT													
BRYAN, YOLANDA T						Description	Code	Assessed	Assessed	801									
1431 IYANNOUGH ROAD UNIT 22U		SUPPLEMENTAL DATA				RESIDNTL	1020	249,700	249,700	FY2024 BARNSTABLE, MA									
CENTERVILLE	MA	02632	Alt Prcl ID Split Zonin B;RC-1 BID Parcel ResExpt Q #DL 1 UNIT 22U #DL 2 BLDG C GIS ID F_979524_2709499		Plan Ref. 315/66, 319/28, 3 Land Ct# #SR Life Estate PP STATU Assoc Pid#	Total		249,700	249,700	VISION									
RECORD OF OWNERSHIP			BK-VOL/PAGE	SALE DATE	Q/U	V/I	SALE PRICE	VC	PREVIOUS ASSESSMENTS (HISTORY)										
BRYAN, YOLANDA T	31529	0304	09-14-2018	Q	I	184,000	00	Year	Code	Assessed	Year	Code	Assessed						
NEEDHAM, JAMES M	12739	0313	12-22-1999	Q	I	69,500	00	2023	1020	208,800	2022	1020	171,400						
KEEFE, KEVIN M	10652	0266	03-14-1997	U	I	43,600	1L				2021	1020	168,000						
FAHIM, RAMFIS B	5050	0245	04-15-1986	Q	V	91,000	U					1020	3,400						
DHIONIS, LOUIS & MARGARET	4307	0103	11-15-1984	Q	I	58,500	U	Total		208,800	Total		171,400	Total	171,400				
EXEMPTIONS			OTHER ASSESSMENTS					This signature acknowledges a visit by a Data Collector or Assessor											
Year	Code	Description	Amount	Code	Description	Number	Amount	Comm Int											
Total			0.00						APPRAISED VALUE SUMMARY										
ASSESSING NEIGHBORHOOD																			
Nbhd	Nbhd Name	B	Tracing	Batch															
0001				HYAN															
NOTES																			
BUILDING PERMIT RECORD						VISIT / CHANGE HISTORY													
Permit Id	Issue Date	Type	Description	Amount	Insp Date	% Comp	Date Comp	Comments	Date	Id	Type	Is	Cd	Purpost/Result					
EXPC-23-1	01-27-2023	835	Sid/Wind/Roof/	22,705		100		Replace 10 windows; no struct Furnish and install 561 SF R38	04-28-2020	WD			FR	Field Review					
EXPC-22-7	10-07-2022	835	Sid/Wind/Roof/	2,500		100			12-14-2018	SR	02			03	Cycl Insp Comp				
									08-28-2014	TP	03			16	In Office Review				
									02-22-2012	TR	03			16	In Office Review				
									05-13-2010	DR	22			22	Change of Address				
									05-23-2008	TP	03			16	In Office Review				
LAND LINE VALUATION SECTION																			
B	Use Code	Description	Zone	Dist	Land Type	Land Units	Unit Price	Size Adj	Site Index	Cond.	Nbhd.	Nbhd. Adj	Notes	Location Adjustmen	Adj Unit P	Land Value			
1	102U	Condominium M	SPLI	4		0 SF	0.00	1.00000	5	1.00	0001	1.000			0.0000	0	0		
Total Card Land Units						0	SF	Parcel Total Land Area						0.00	Total Land Value				0

CONSTRUCTION DETAIL			CONSTRUCTION DETAIL (CONTINUED)		
Element	Cd	Description	Element	Cd	Description
Style	55	Condominium			
Model	05	Res Condo			
Bedrm Func	C	Average			
Stories	1	1 Story			
Occupancy	0				
Interior Wall 1	03	Plastered			
Interior Wall 2					
Interior Floor 1	14	Carpet			
Interior Floor 2	09	Pine/Soft Wood			
Heat Fuel	04	Electric			
Heat Type	07	Elec Baseboard			
AC Type	01	None			
Bedrooms	02	2 Bedrooms			
Full Baths	1	1 Full			
Half Baths	0				
Extra Fixtures					
Total Rooms	5	5 Rooms			
Bath Style					
Kitchen Style					
Master Deed L	1155				
Bath Split	10	1 Full-0 Half			
Foundation	01	Poured Conc.			
AC Type Alt					
Sewer Occupan					
CONDO DATA					
Parcel Id	104261	C 0450	Owne	3.3	
	STRAWBERRY HIL	B 1	S 1		
Adjust Type	Code	Description	Factor%		
Condo Flr	END	END UNIT	100		
Condo Unit	MKT0	MKT0	100		
COST / MARKET VALUATION					
Building Value New		274,001			
Year Built		1976			
Effective Year Built		1998			
Depreciation Code		A			
Remodel Rating					
Year Remodeled					
Depreciation %		16			
Functional Obsol		0			
External Obsol		0			
Trend Factor		1			
Condition					
Condition %					
Percent Good		84			
Cns Sect Rcnd		230,200			
Dep % Ovr					
Dep Ovr Comment					
Misc Imp Ovr					
Misc Imp Ovr Comment					
Cost to Cure Ovr					
Cost to Cure Ovr Comment					

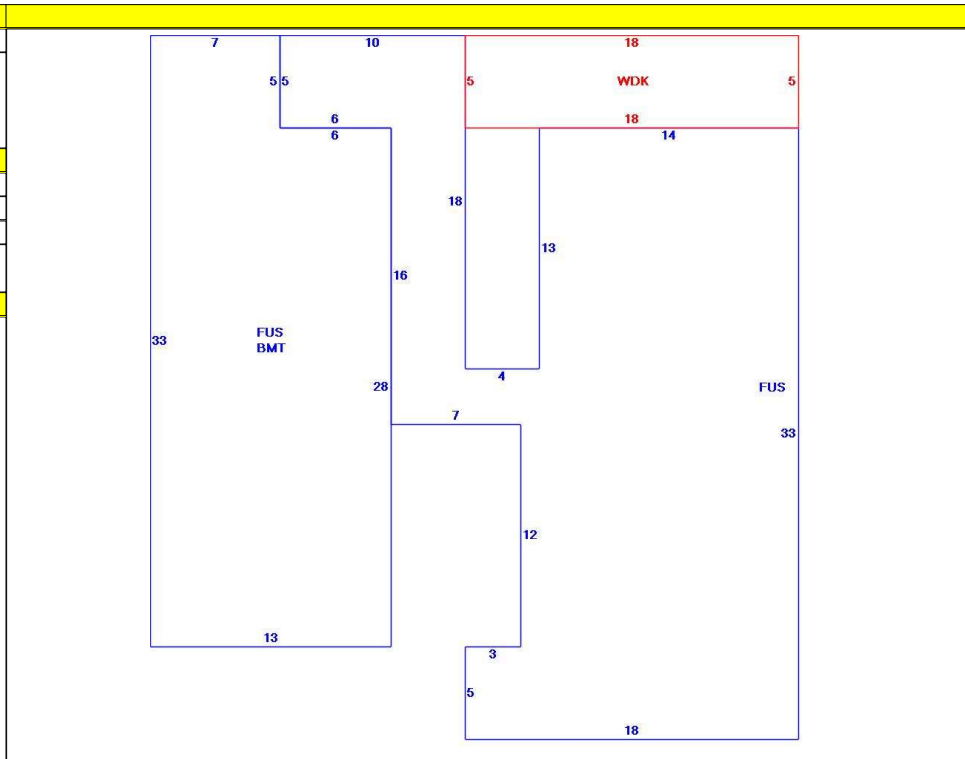

OB - OUTBUILDING & YARD ITEMS(L) / XF - BUILDING EXTRA FEATURES(B)										
Code	Description	L/B	Units	Unit Price	Yr Blt	Cond. Cd	% Gd	Grade	Grade Adj.	Appr. Value
FPL1	Fireplace 1 sto	B	1	5000.00	1999		84		0.00	4,200
BMT	Basement-Unfi	B	399	26.01	1999		84		0.00	11,900
WDC	Wood Decking	L	90	20.00	2018		98		0.00	3,400

BUILDING SUB-AREA SUMMARY SECTION						
Code	Description	Living Area	Floor Area	Eff Area	Unit Cost	Undeprec Value
BMT	Basement Area	0	399	0	0.00	0
FUS	Upper Story	1,019	1,019	1,019	268.89	274,001
WDC	Wood Deck	0	90	0	0.00	0
Ttl Gross Liv / Lease Area		1,019	1,508	1,019		274,001

