

CONSTRUCTION DETAIL			CONSTRUCTION DETAIL (CONTINUED)		
Element	Cd	Description	Element	Cd	Description
Style	55	Condominium			
Model	05	Res Condo			
Bedrm Func	C	Average			
Stories	1	1 Story			
Occupancy	0				
Interior Wall 1	03	Plastered			
Interior Wall 2					
Interior Floor 1	14	Carpet			
Interior Floor 2	09	Pine/Soft Wood			
Heat Fuel	04	Electric			
Heat Type	07	Elec Baseboard			
AC Type	01	None			
Bedrooms	02	2 Bedrooms			
Full Baths	1	1 Full			
Half Baths	0				
Extra Fixtures					
Total Rooms	5	5 Rooms			
Bath Style					
Kitchen Style					
Master Deed L	1155				
Bath Split	10	1 Full-0 Half			
Foundation	01	Poured Conc.			
AC Type Alt					
Sewer Occupan					
CONDO DATA					
Parcel Id	104261	C 0450	Owne	3.3	
	STRAWBERRY HIL	B 1	S 1		
Adjust Type	Code	Description	Factor%		
Condo Flr			100		
Condo Unit	MKT0	MKT0	100		
COST / MARKET VALUATION					
Building Value New		274,001			
Year Built		1976			
Effective Year Built		1998			
Depreciation Code		A			
Remodel Rating					
Year Remodeled		16			
Depreciation %		0			
Functional Obsol		0			
External Obsol		0			
Trend Factor		1			
Condition					
Condition %		84			
Pcnt Good		230,200			
Cns Sect Rcnd					
Dep % Ovr					
Dep Ovr Comment					
Misc Imp Ovr					
Misc Imp Ovr Comment					
Cost to Cure Ovr					
Cost to Cure Ovr Comment					

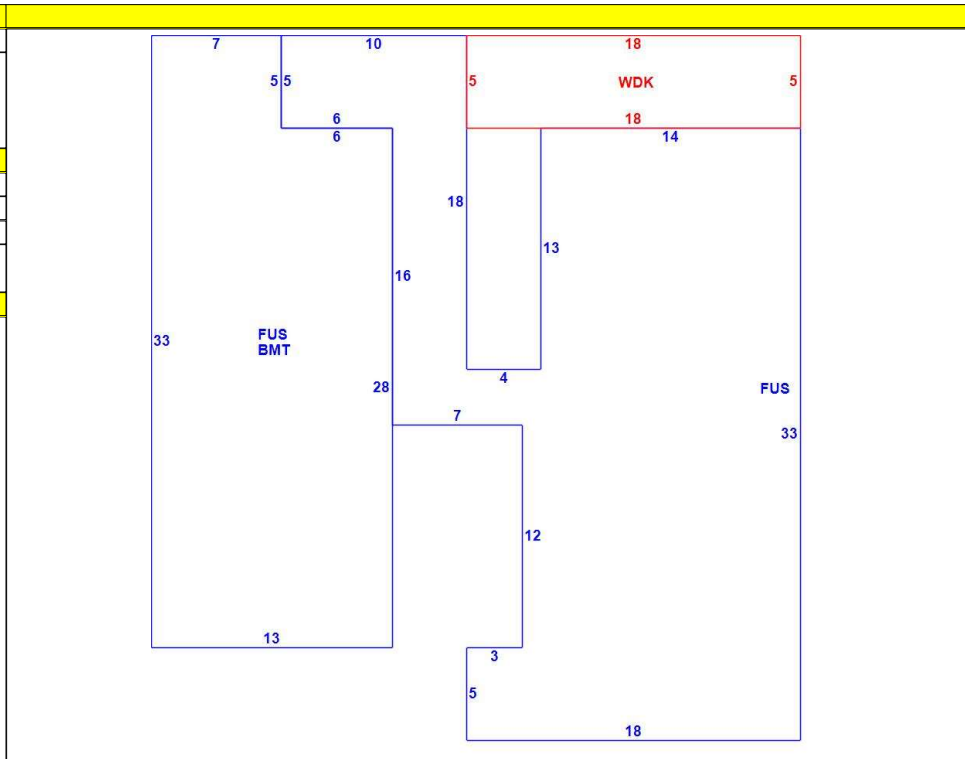

OB - OUTBUILDING & YARD ITEMS(L) / XF - BUILDING EXTRA FEATURES(B)										
Code	Description	L/B	Units	Unit Price	Yr Blt	Cond. Cd	% Gd	Grade	Grade Adj.	Appr. Value
FPL1	Fireplace 1 sto	B	1	5000.00	1999		84		0.00	4,200
BMT	Basement-Unfi	B	399	26.01	1999		84		0.00	11,900
WDC	Wood Decking	L	90	20.00	2018		98		0.00	3,400

BUILDING SUB-AREA SUMMARY SECTION						
Code	Description	Living Area	Floor Area	Eff Area	Unit Cost	Undeprec Value
BMT	Basement Area	0	399	0	0.00	0
FUS	Upper Story	1,019	1,019	1,019	268.89	274,001
WDC	Wood Deck	0	90	0	0.00	0
Ttl Gross Liv / Lease Area		1,019	1,508	1,019		274,001

