

CURRENT OWNER		TOPO	UTILITIES	STRT / ROAD	LOCATION	CURRENT ASSESSMENT						801 FY2024 BARNSTABLE, MA  <b>VISION</b>						
NOWAK, STANLEY P TR VILLAGE TRUST PO BOX 550  BARNSTABLE MA 02630						Description	Code	Assessed	Assessed									
		SUPPLEMENTAL DATA				RESIDNTL	1020	249,700	249,700									
		Alt Prcl ID	Split Zonin B;RC-1	Plan Ref. 315/66, 319/31, 3				Total	249,700	249,700								
		BID Parcel		Land Ct#														
		ResExpt Q		#SR														
		#DL 1	UNIT 30U	Life Estate														
		#DL 2	BLDG D	PP STATU														
		GIS ID	F_979524_2709499	Assoc Pid#														
RECORD OF OWNERSHIP		BK-VOL/PAGE	SALE DATE	Q/U	V/I	SALE PRICE	VC	PREVIOUS ASSESSMENTS (HISTORY)										
NOWAK, STANLEY P TR		27808 0076	11-06-2013	U	I	1	1A	Year	Code	Assessed	Year	Code	Assessed	Year	Code	Assessed		
NOWAK, GREGORY		27808 0069	11-06-2013	U	I	94,000	1	2023	1020	208,800	2022	1020	171,400	2021	1020	168,000		
LISET, PRISCILLA K TR		21845 0234	03-13-2007	U	I	1	1A								1020	3,400		
LISET, PRISCILLA K		21007 0304	05-17-2006	U	I	1	1A											
LISET, GLEN R		14930 0156	03-15-2002	Q	I	127,500	00											
		Total						Total	208,800	Total	171,400	Total	171,400	Total	171,400			
EXEMPTIONS			OTHER ASSESSMENTS				This signature acknowledges a visit by a Data Collector or Assessor											
Year	Code	Description	Amount	Code	Description	Number	Amount	Comm Int										
		Total	0.00															
ASSESSING NEIGHBORHOOD								APPRAISED VALUE SUMMARY										
Nbhd	Nbhd Name		B		Tracing		Batch		Appraised Bldg. Value (Card)				230,200					
0001							HYAN		Appraised Xf (B) Value (Bldg)				16,100					
								Appraised Ob (B) Value (Bldg)				3,400						
								Appraised Land Value (Bldg)				0						
								Special Land Value				0						
								Total Appraised Parcel Value				249,700						
								Valuation Method				C						
								Total Appraised Parcel Value				249,700						
BUILDING PERMIT RECORD								VISIT / CHANGE HISTORY										
Permit Id	Issue Date	Type	Description	Amount	Insp Date	% Comp	Date Comp	Comments	Date	Id	Type	Is	Cd	Purpost/Result				
20-78	01-13-2020	835	Sid/Wind/Roof/	0		100		10 WINDOWS FOR UNIT NU	04-28-2020	WD			FR	Field Review				
									12-14-2018	SR	02		03	Cycl Insp Comp				
									02-24-2015	TR	03		16	In Office Review				
									08-28-2014	TP	03		16	In Office Review				
LAND LINE VALUATION SECTION																		
B	Use Code	Description	Zone	Dist	Land Type	Land Units	Unit Price	Size Adj	Site Index	Cond.	Nbhd.	Nbhd. Adj	Notes	Location Adjustmen	Adj Unit P	Land Value		
1	102U	Condominium M	SPLI	4		0 SF	0.00	1.00000	5	1.00	0001	1.000		0.0000	0	0		
Total Card Land Units						0 SF	Parcel Total Land Area						0.00	Total Land Value				0

CONSTRUCTION DETAIL			CONSTRUCTION DETAIL (CONTINUED)		
Element	Cd	Description	Element	Cd	Description
Style	55	Condominium			
Model	05	Res Condo			
Bedrm Func	C	Average			
Stories	1	1 Story			
Occupancy	0				
Interior Wall 1	03	Plastered			
Interior Wall 2					
Interior Floor 1	14	Carpet			
Interior Floor 2					
Heat Fuel	04	Electric			
Heat Type	07	Elec Baseboard			
AC Type	01	None			
Bedrooms	02	2 Bedrooms			
Full Baths	1	1 Full			
Half Baths	0				
Extra Fixtures					
Total Rooms	5	5 Rooms			
Bath Style					
Kitchen Style					
Master Deed L	1155				
Bath Split	10	1 Full-0 Half			
Foundation	01	Poured Conc.			
AC Type Alt					
Sewer Occupan					
<b>CONDO DATA</b>					
Parcel Id	104261	C 0450	Owne	3.3	
	STRAWBERRY HIL	B 1	S 1		
Adjust Type	Code	Description	Factor%		
Condo Flr	END	END UNIT	100		
Condo Unit	MKT0	MKT0	100		
<b>COST / MARKET VALUATION</b>					
Building Value New		274,001			
Year Built		1976			
Effective Year Built		1998			
Depreciation Code		A			
Remodel Rating					
Year Remodeled		16			
Depreciation %		0			
Functional Obsol		0			
External Obsol		0			
Trend Factor		1			
Condition					
Condition %		84			
Pcnt Sect Rcnld		230,200			
Dep % Ovr					
Dep Ovr Comment					
Misc Imp Ovr					
Misc Imp Ovr Comment					
Cost to Cure Ovr					
Cost to Cure Ovr Comment					

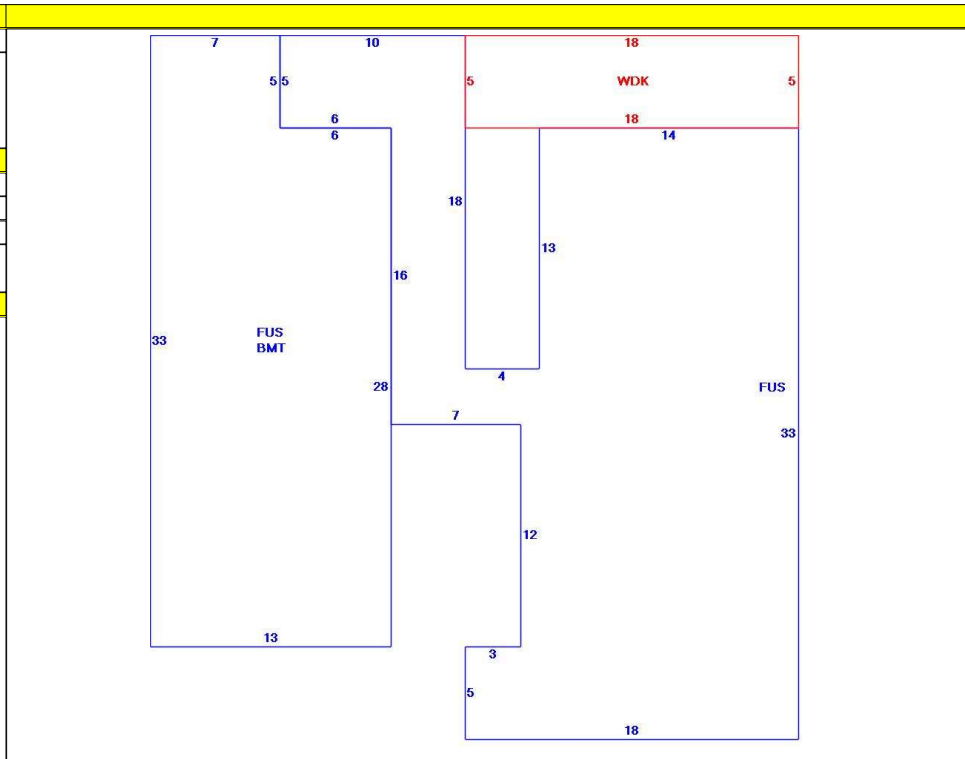

OB - OUTBUILDING & YARD ITEMS(L) / XF - BUILDING EXTRA FEATURES(B)										
Code	Description	L/B	Units	Unit Price	Yr Blt	Cond. Cd	% Gd	Grade	Grade Adj.	Appr. Value
FPL1	Fireplace 1 sto	B	1	5000.00	1999		84		0.00	4,200
BMT	Basement-Unfi	B	399	26.01	1999		84		0.00	11,900
WDC	Wood Decking	L	90	20.00	2018		98		0.00	3,400

BUILDING SUB-AREA SUMMARY SECTION						
Code	Description	Living Area	Floor Area	Eff Area	Unit Cost	Undeprec Value
BMT	Basement Area	0	399	0	0.00	0
FUS	Upper Story	1,019	1,019	1,019	268.89	274,001
WDC	Wood Deck	0	90	0	0.00	0
Ttl Gross Liv / Lease Area		1,019	1,508	1,019		274,001

