

CURRENT OWNER		TOPO		UTILITIES		STRT / ROAD		LOCATION		CURRENT ASSESSMENT				801 FY2024 BARNSTABLE, MA VISION						
BRODHEAD, MARCIA PO BOX 810 BARNSTABLE MA 02630		1	Level	2	Public Water	1	Paved			Description	Code	Assessed	Assessed			RESIDNTL RES LAND	1010 1010	362,800 242,100	362,800 242,100	
		4	Gas																	
		6	Septic																	
SUPPLEMENTAL DATA										Total				604,900	604,900					
Alt Prcl ID		Split Zonin		Plan Ref.		258/66														
BID Parcel		#SR		Land Ct#																
ResExpt Q		YES:		Life Estate		PP STATU														
#DL 1		LOT 2		Assoc Pid#																
#DL 2																				
GIS ID		F_982003_2718091																		
RECORD OF OWNERSHIP		BK-VOL/PAGE		SALE DATE		Q/U		V/I		SALE PRIC		VC		PREVIOUS ASSESSMENTS (HISTORY)						
BRODHEAD, MARCIA		34015	137	04-15-2021		U	I			1	1F	Year	Code	Assessed	Year	Code	Assessed	Year	Code	Assessed
HICKEY, WILLIAM A III & ROCKWELL, TH		34015	132	04-15-2021		U	I			0	1F	2023	1010	324,100	2022	1010	278,700	2021	1010	229,000
BRODHEAD, NANCY N ESTATE OF		BA21P04	0	12-29-2020		U	I			0	1F		1010	220,100		1010	151,400		1010	153,700
BRODHEAD, NANCY N		11368	0053	04-21-1998		U	I			1	1A								1010	14,600
BRODHEAD, BOYD E & NANCY N		11230	0193	02-18-1998		U	I			100	1A									
Total												544,200	Total	430,100	Total	397,300				
EXEMPTIONS				OTHER ASSESSMENTS				This signature acknowledges a visit by a Data Collector or Assessor												
Year	Code	Description	Amount	Code	Description	Number	Amount	Comm Int												
2011	5C	RESIDENTIAL EXEMPTION	0.00																	
Total			0.00																	
ASSESSING NEIGHBORHOOD																				
Nbhd		Nbhd Name		B		Tracing		Batch												
0107								BARN												
NOTES																				
BUILDING PERMIT RECORD										VISIT / CHANGE HISTORY										
Permit Id	Issue Date	Type	Description	Amount	Insp Date	% Comp	Date Comp	Comments		Date	Id	Type	Is	Cd	Purpost/Result					
19-785	03-15-2019	822	Insulation	3,342		100		Air sealing and Weatherization		05-12-2020	DM			FR	Field Review					
48870	09-25-2000	AD	Addition	16,128	03-09-2001	100	01-01-2001			03-08-2017	JR	01		03	Cycl Insp Comp					
										02-03-2014	JR	03		16	In Office Review					
										09-04-2009	MA	22		22	Change of Address					
										03-09-2001	MF	02		02	Bldg Permit Completed					
										09-18-2000	PT	01		00	Meas/Listed-Interior Acces					
LAND LINE VALUATION SECTION																				
B	Use Code	Description	Zone	LA	Land Units	Unit Price	Size Adj	AC Disc	Site Index	Cond.	Nbhd.	Nbhd. Adj	Notes	Location Adjustmen	Adj Unit P	Land Value				
1	1010	Single Fam M-0	RF-2	1	0.790	AC	176,344.00	1.24114	1.0000	5	1.00	0107	1.400		1.0000	306,415.3	242,100			
Total Card Land Units					0.79	AC	Parcel Total Land Area					0.79	Total Land Value				242,100			

CONSTRUCTION DETAIL			CONSTRUCTION DETAIL (CONTINUED)		
Element	Cd	Description	Element	Cd	Description
Style	04	Cape Cod			
Model	01	Residential			
Grade:	C+	Average Plus			
Stories	1.4				
Exterior Wall 1	14	Wood Shingle			
Exterior Wall 2					
CONDO DATA					
Roof Structure	03	Gable/Hip	Parcel Id	C	Ownr 0.0
Roof Cover	03	Asph/F Gls/Cmp		B	S
Interior Wall 1	05	Drywall	Adjust Type	Code	Description Factor%
Interior Wall 2			Condo Flr		Condo Unit
Interior Floor 1	12	Hardwood	COST / MARKET VALUATION		
Interior Floor 2	14	Carpet	Building Value New 387,910		
Heat Fuel	02	Oil	Year Built	1972	
Heat Type	05	Hot Water	Effective Year Built	1992	
AC Type	01	None	Depreciation Code	A	
Bedrooms	02	2 Bedrooms	Remodel Rating		
Full Baths	2		Year Remodeled		
Half Baths	0		Depreciation %	21	
Extra Fixtures			Functional Obsol	0	
Total Rooms	6	6 Rooms	External Obsol	0	
Bath Style			Trend Factor	1	
Kitchen Style			Condition		
Occupancy			Condition %		
Usrflid 105			Percent Good	79	
Accessory Apt			RCNLD	306,400	
Foundation Alt	02	Conc. Block	Dep % Ovr		
Rms Prts			Dep Ovr Comment		
Bath Split	20	2 Full-0 Half	Misc Imp Ovr		
			Misc Imp Ovr Comment		
			Cost to Cure Ovr		
			Cost to Cure Ovr Comment		

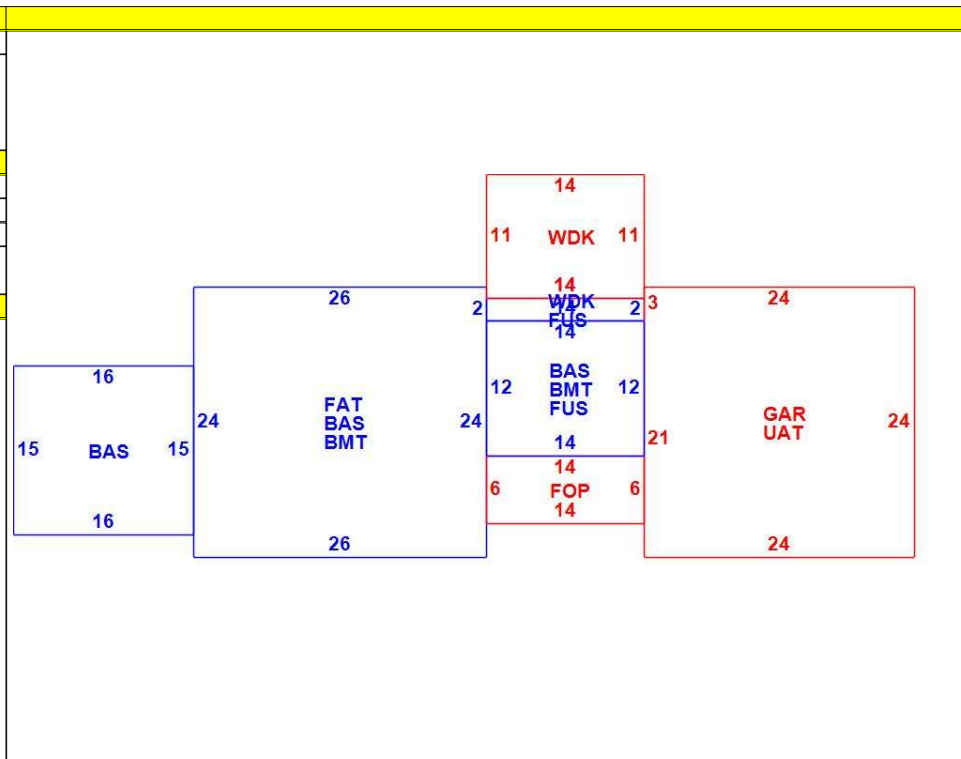

OB - OUTBUILDING & YARD ITEMS(L) / XF - BUILDING EXTRA FEATURES(B)										
Code	Description	L/B	Units	Unit Price	Yr Blt	Cond. Cd	% Gd	Grade	Grade Adj.	Appr. Value
FPL2	Fireplace 1.5 s	B	1	6000.00	1994		79	00	0.00	4,700
BRN1	Barn - 1 Story	L	567	29.38	1992		73	00	1.00	12,200
WDC	Wood Decking	L	182	20.00	1996		54		0.00	2,400
FOPC	Open Prch-roo	B	84	55.00	1994		79		0.00	3,200
GAR	Attached Gara	B	576	40.00	1994		79		0.00	16,100
BMT	Basement-Unfi	B	792	26.01	1994		79		0.00	17,800

BUILDING SUB-AREA SUMMARY SECTION							
Code	Description	Living Area	Floor Area	Eff Area	Unit Cost	Undeprec Value	
BAS	First Floor	1,032	1,032	1,032	281.09	290,089	
BMT	Basement Area	0	792	0	0.00	0	
FAT	Attic, Finished	94	624	94	42.34	26,423	
FOP	Open Porch	0	84	0	0.00	0	
FUS	Upper Story	196	196	196	281.09	55,094	
GAR	Attached Garage	0	576	0	0.00	0	
UAT	Attic, Unfinished	0	576	58	28.30	16,303	
WDK	Wood Deck	0	182	0	0.00	0	
Ttl Gross Liv / Lease Area		1,322	4,062	1,380		387,909	

