

CURRENT OWNER		TOPO	UTILITIES	STRT / ROAD	LOCATION	CURRENT ASSESSMENT			
SHEEHAN, TIMOTHY J & LINDA M 51 PINE LANE BARNSTABLE MA 02630		1 Level	2 Public Water	1 Paved		Description	Code	Assessed	Assessed
			4 Gas			RESIDNTL	1010	501,000	501,000
			6 Septic			RES LAND	1010	234,700	234,700
SUPPLEMENTAL DATA									
Alt Prcl ID		Split Zonin		Plan Ref. 249/95					
BID Parcel		ResExpt Q		Land Ct#					
#DL 1 LOT 2		#DL 2		Life Estate					
GIS ID F_981853_2718481		Assoc Pid#							
						Total		735,700	735,700

801
 FY2024
 BARNSTABLE, MA

VISION

RECORD OF OWNERSHIP		BK-VOL/PAGE	SALE DATE	Q/U	V/I	SALE PRIC	VC	PREVIOUS ASSESSMENTS (HISTORY)						
SHEEHAN, TIMOTHY J & LINDA M		28006	0216	02-27-2014	Q	I	440,000	00	Year	Code	Assessed	Year	Code	Assessed
ZUPKO, KARIN G		#BA10P2	0	03-09-2011	U	I	0	1	2023	1010	448,700	2022	1010	387,800
ZUPKO, HELEN		12041	0264	02-03-1999	U	I	0	1A		1010	213,400		1010	146,800
ZUPKO, GEORGE R & HELEN H		9531	0296	01-15-1995	Q	I	227,500	U					1010	2,700
CHRISTINE, G HOWARD &		4856	0282	12-15-1985	Q	I	196,500	U						
						Total			662,100	Total		534,600	Total	489,600

EXEMPTIONS			OTHER ASSESSMENTS					
Year	Code	Description	Amount	Code	Description	Number	Amount	Comm Int
Total			0.00					

This signature acknowledges a visit by a Data Collector or Assessor

ASSESSING NEIGHBORHOOD				APPRAISED VALUE SUMMARY			
Nbhd	Nbhd Name	B	Tracing	Batch			
0107				BARNS			
NOTES							
				Appraised Bldg. Value (Card) 413,700			
				Appraised Xf (B) Value (Bldg) 84,600			
				Appraised Ob (B) Value (Bldg) 2,700			
				Appraised Land Value (Bldg) 234,700			
				Special Land Value 0			
				Total Appraised Parcel Value 735,700			
				Valuation Method C			
				Total Appraised Parcel Value 735,700			

BUILDING PERMIT RECORD								VISIT / CHANGE HISTORY						
Permit Id	Issue Date	Type	Description	Amount	Insp Date	% Comp	Date Comp	Comments	Date	Id	Type	Is	Cd	Purpost/Result
20-218	01-24-2020	835	Sid/Wind/Roof/	5,950		100		4 Windows	05-12-2020	DM			FR	Field Review
20-160	01-21-2020	822	Insulation	5,419		100		air sealing, weatherstrip doors,	02-06-2020	CK	22		22	Change of Address
18-527	02-23-2018	835	Sid/Wind/Roof/	26,364		100		Replacement Windows (3) U-V	03-08-2017	JR	01		03	Cycl Insp Comp
									05-16-2014	JR	03		16	In Office Review
									07-13-2012	TR	03		16	In Office Review
									09-18-2000	PT	01		00	Meas/Listed-Interior Acces

LAND LINE VALUATION SECTION																	
B	Use Code	Description	Zone	LA	Land Units	Unit Price	Size Adj	AC Disc	Site Index	Cond.	Nbhd.	Nbhd. Adj	Notes	Location Adjustmen	Adj Unit P	Land Value	
1	1010	Single Fam M-0	RF-2	1	0.650	AC	176,344.00	1.46256	1.0000	5	1.00	0107	1.400		1.0000	361,081.9	234,700
Total Card Land Units					0.65	AC	Parcel Total Land Area					0.65	Total Land Value			234,700	

CONSTRUCTION DETAIL			CONSTRUCTION DETAIL (CONTINUED)		
Element	Cd	Description	Element	Cd	Description
Style	04	Cape Cod			
Model	01	Residential			
Grade:	C	Average			
Stories	1.3				
Exterior Wall 1	14	Wood Shingle			
Exterior Wall 2					
RooF Structure	03	Gable/Hip			
RooF Cover	03	Asph/F Gls/Cmp			
Interior Wall 1	03	Plastered			
Interior Wall 2					
Interior Floor 1	12	Hardwood			
Interior Floor 2					
Heat Fuel	03	Gas			
Heat Type	04	Hot Air			
AC Type	03	Central			
Bedrooms	02	2 Bedrooms			
Full Baths	2				
Half Baths	0				
Extra Fixtures					
Total Rooms	7				
Bath Style					
Kitchen Style					
Occupancy					
Usrflid 105					
Accessory Apt					
Foundation Alt	01	Poured Conc.			
Rms Prts					
Bath Split	20	2 Full-0 Half			

CONDO DATA				
Parcel Id		C	Ownr	0.0
Adjust Type	Code	Description	Factor%	
Condo Flr				
Condo Unit				

COST / MARKET VALUATION	
Building Value New	523,724
Year Built	1972
Effective Year Built	1992
Depreciation Code	A
Remodel Rating	
Year Remodeled	
Depreciation %	21
Functional Obsol	0
External Obsol	0
Trend Factor	1
Condition	
Condition %	
Percent Good	79
RCNLD	413,700
Dep % Ovr	
Dep Ovr Comment	
Misc Imp Ovr	
Misc Imp Ovr Comment	
Cost to Cure Ovr	
Cost to Cure Ovr Comment	

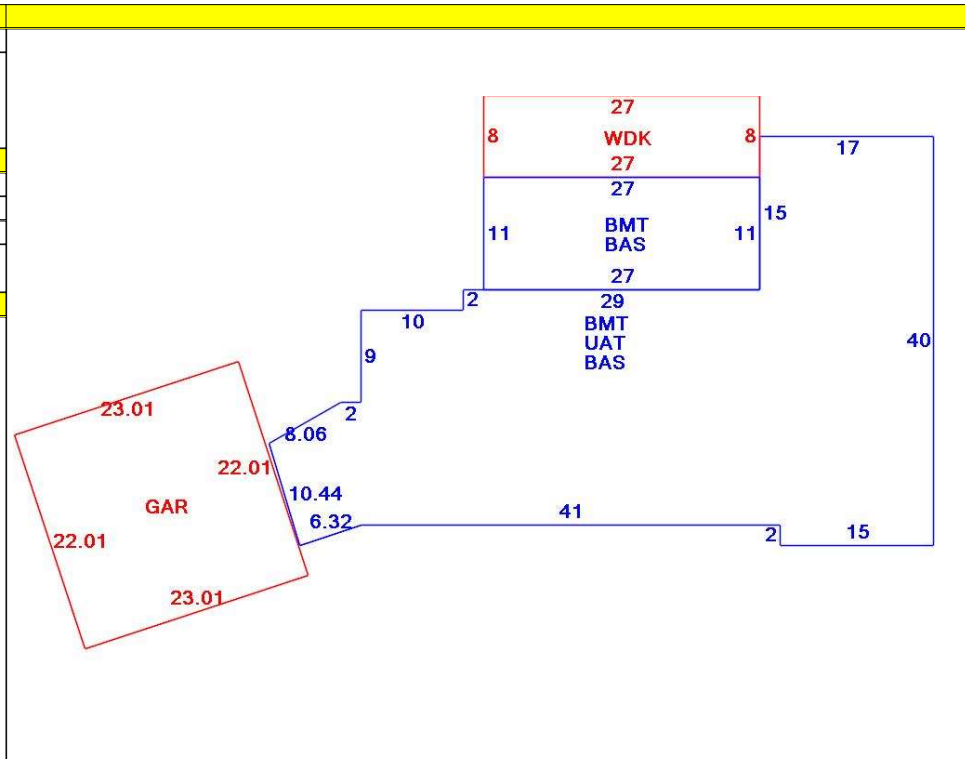

OB - OUTBUILDING & YARD ITEMS(L) / XF - BUILDING EXTRA FEATURES(B)										
Code	Description	L/B	Units	Unit Price	Yr Blt	Cond. Cd	% Gd	Grade	Grade Adj.	Appr. Value
FPL2	Fireplace 1.5 s	B	1	6000.00	1994		79		0.00	4,700
BFA1	Bsmt Fin-Goo	B	1,200	32.56	1994		79		0.00	30,900
WDC	Wood Decking	L	216	20.00	1996		54		0.00	2,700
GAR	Attached Gara	B	506	40.00	1994		79		0.00	14,700
BMT	Basement-Unfi	B	1,930	26.01	1994		79		0.00	34,300

BUILDING SUB-AREA SUMMARY SECTION						
Code	Description	Living Area	Floor Area	Eff Area	Unit Cost	Undeprec Value
BAS	First Floor	1,941	1,941	1,941	248.80	482,921
BMT	Basement Area	0	1,941	0	0.00	0
GAR	Attached Garage	0	506	0	0.00	0
UAT	Attic, Unfinished	0	1,644	164	24.82	40,803
WDK	Wood Deck	0	216	0	0.00	0
Ttl Gross Liv / Lease Area		1,941	6,248	2,105		523,724

