

CURRENT OWNER		TOPO	UTILITIES	STRT / ROAD	LOCATION	CURRENT ASSESSMENT			
RENEHAN, JOHN P JR & PATRICIA A 400 MEADOWBROOK AVE ST DAVIDS PA 19087		1 Sloping	2 Public Water	1 Paved		Description	Code	Assessed	Assessed
			4 Gas			RESIDENTL	1010	638,200	638,200
			6 Septic			RES LAND	1010	285,000	285,000
SUPPLEMENTAL DATA									
Alt Prcl ID		Split Zonin		Plan Ref. 19/143					
BID Parcel		ResExpt Q		Land Ct#					
#DL 1 LOT 197		#DL 2		#SR					
GIS ID F_946286_2686635		Assoc Pid#		Life Estate					
				PP STATU					
						Total		923,200	923,200

801
 FY2024
 BARNSTABLE, MA

VISION

RECORD OF OWNERSHIP		BK-VOL/PAGE	SALE DATE	Q/U	V/I	SALE PRIC	VC	PREVIOUS ASSESSMENTS (HISTORY)								
RENEHAN, JOHN P JR & PATRICIA A		7553 0306	05-15-1991	Q	I	140,000	U	Year	Code	Assessed	Year	Code	Assessed	Year	Code	Assessed
PERRY, WILLIAM H III & FISHER, SONJA		5624 0230	03-15-1987	U	I		A	2023	1010	540,800	2022	1010	452,800	2021	1010	378,000
PERRY, TAIMI C		2057 0139	06-18-1974	U		0			1010	281,900		1010	180,600		1010	191,900
												1010				7,100
								Total		822,700	Total		633,400	Total		577,000

EXEMPTIONS			OTHER ASSESSMENTS					
Year	Code	Description	Amount	Code	Description	Number	Amount	Comm Int
			Total				0.00	

This signature acknowledges a visit by a Data Collector or Assessor

APPRAISED VALUE SUMMARY

Appraised Bldg. Value (Card)	553,100
Appraised Xf (B) Value (Bldg)	78,000
Appraised Ob (B) Value (Bldg)	7,100
Appraised Land Value (Bldg)	285,000
Special Land Value	0
Total Appraised Parcel Value	923,200
Valuation Method	C
Total Appraised Parcel Value	923,200

ASSESSING NEIGHBORHOOD			
Nbhd	Nbhd Name	B	Tracing
0108			COTUIT

NOTES									

BUILDING PERMIT RECORD									VISIT / CHANGE HISTORY					
Permit Id	Issue Date	Type	Description	Amount	Insp Date	% Comp	Date Comp	Comments	Date	Id	Type	Is	Cd	Purpost/Result
BLDR-22-50	05-02-2022	880	Alt-Int work-Res	58,500	01-20-2023	100	06-30-2023	Finish basement for a family/e	06-30-2023	TR	03		02	Bldg Permit Completed
201407470	11-13-2014	RA	Remodel-Additi	300,000	06-30-2015	100	06-30-2015	ADD BATH, REMODEL 2 EXI	06-09-2020	WD			FR	Field Review
30746	05-07-1998	AD	Addition	3,000	06-01-1999	100	06-30-1999	14X18 FLAT CEILING TO CAT	07-20-2015	SR	01		02	Bldg Permit Completed
									01-29-2014	JR	03		16	In Office Review
									03-12-2013	RB	03		03	Cycl Insp Comp

LAND LINE VALUATION SECTION																		
B	Use Code	Description	Zone	LA	Land Units	Unit Price	Size Adj	AC Disc	Site Index	Cond.	Nbhd.	Nbhd. Adj	Notes	Location Adjustmen	Adj Unit P	Land Value		
1	1010	Single Fam M-0	RF	2	0.650 AC	176,344.00	1.46256	1.0000	5	1.00	0108	1.700			1.0000	438,461.7		
					Total Card Land Units	0.65 AC						Parcel Total Land Area	0.65				Total Land Value	285,000

CONSTRUCTION DETAIL			CONSTRUCTION DETAIL (CONTINUED)		
Element	Cd	Description	Element	Cd	Description
Style	04	Cape Cod			
Model	01	Residential			
Grade:	B+	Custom Plus			
Stories	1.75	1 3/4 Stories			
Exterior Wall 1	14	Wood Shingle			
Exterior Wall 2					
RooF Structure	03	Gable/Hip			
RooF Cover	03	Asph/F Gls/Cmp			
Interior Wall 1	05	Drywall			
Interior Wall 2	06	Cust Wd Panel			
Interior Floor 1	12	Hardwood			
Interior Floor 2	09	Pine/Soft Wood			
Heat Fuel	03	Gas			
Heat Type	05	Hot Water			
AC Type	03	Central			
Bedrooms	04	4 Bedrooms			
Full Baths	3				
Half Baths	0				
Extra Fixtures					
Total Rooms	7				
Bath Style					
Kitchen Style					
Occupancy					
Usrflid 105					
Accessory Apt					
Foundation Alt	01	Poured Conc.			
Rms Prts					
Bath Split	30	3 Full-0 Half			

CONDO DATA				
Parcel Id		C		Ownr 0.0
			B	S
Adjust Type	Code	Description	Factor%	
Condo Flr				
Condo Unit				

COST / MARKET VALUATION	
Building Value New	658,494
Year Built	1940
Effective Year Built	1999
Depreciation Code	E
Remodel Rating	
Year Remodeled	
Depreciation %	16
Functional Obsol	0
External Obsol	0
Trend Factor	1
Condition	
Condition %	
Percent Good	84
RCNLD	553,100
Dep % Ovr	
Dep Ovr Comment	
Misc Imp Ovr	
Misc Imp Ovr Comment	
Cost to Cure Ovr	
Cost to Cure Ovr Comment	

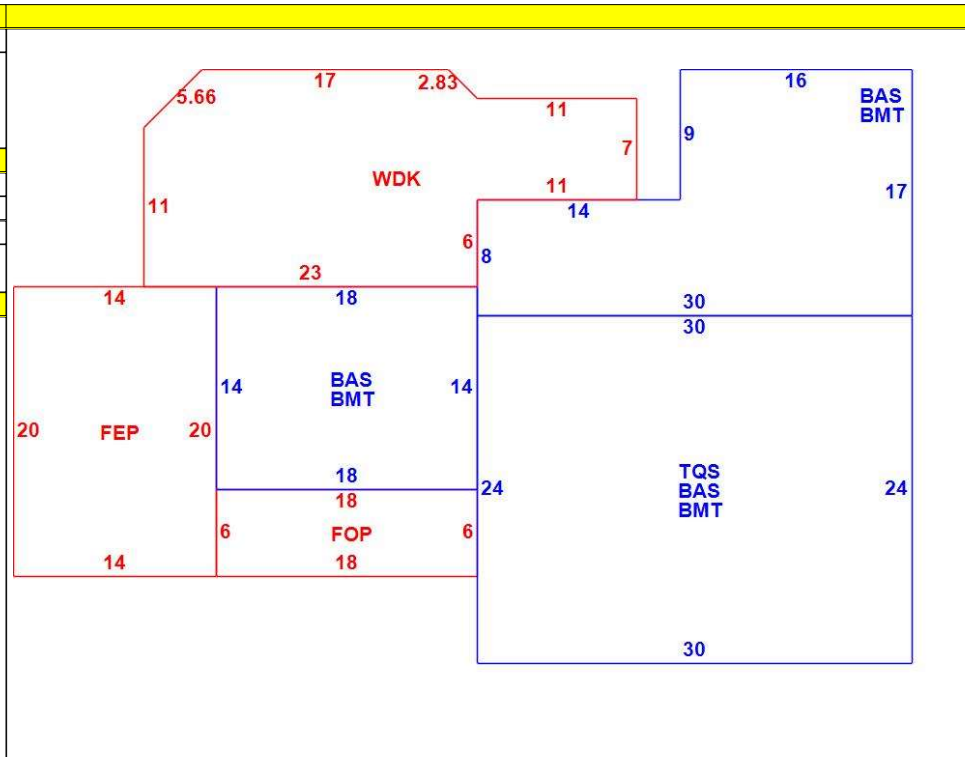

OB - OUTBUILDING & YARD ITEMS(L) / XF - BUILDING EXTRA FEATURES(B)										
Code	Description	L/B	Units	Unit Price	Yr Blt	Cond. Cd	% Gd	Grade	Grade Adj.	Appr. Value
FPL2	Fireplace 1.5 s	B	1	6000.00	1999		84		0.00	5,000
BMT	Basement-Unfi	B	1,356	26.01	1999		84		0.00	27,600
WDC	Wood Decking	L	412	20.00	2014		90		0.00	7,100
FOP	Open Porch-ro	B	108	55.00	1999		84		0.00	4,900
FEP	Enclosed porc	B	280	70.00	1999		84		0.00	13,100
BFA1	Bsmt Fin-Goo	B	1,000	32.56			84		0.00	27,400

BUILDING SUB-AREA SUMMARY SECTION						
Code	Description	Living Area	Floor Area	Eff Area	Unit Cost	Undeprec Value
BAS	First Floor	1,356	1,356	1,356	361.02	489,538
BMT	Basement Area	0	1,356	0	0.00	0
FEP	Enclosed Porch	0	280	0	0.00	0
FOP	Open Porch	0	108	0	0.00	0
TQS	Three Quarter Story	468	720	468	234.66	168,956
WDC	Wood Deck	0	412	0	0.00	0
Ttl Gross Liv / Lease Area		1,824	4,232	1,824		658,494

