

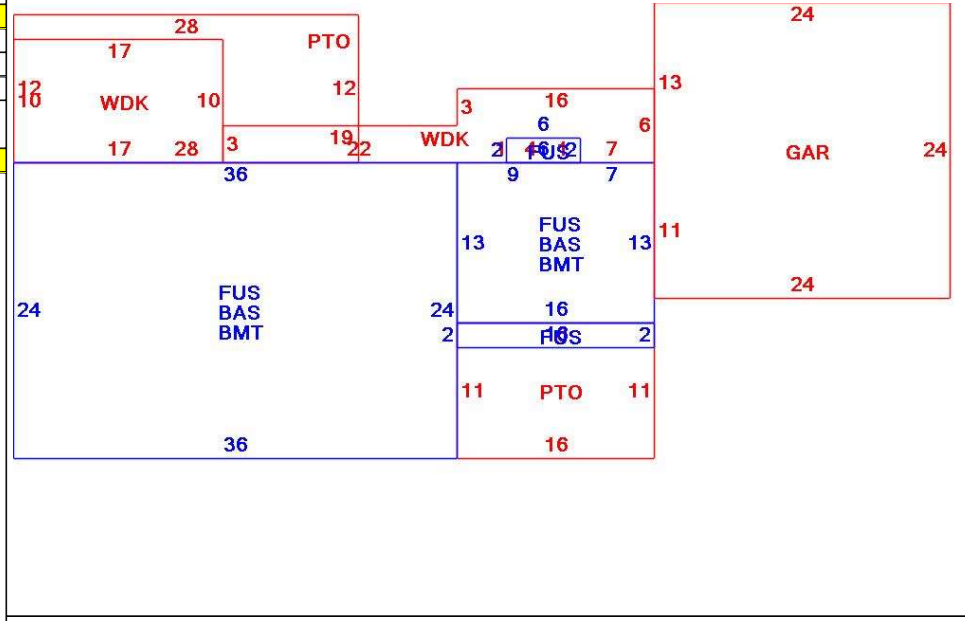

CONSTRUCTION DETAIL			CONSTRUCTION DETAIL (CONTINUED)		
Element	Cd	Description	Element	Cd	Description
Style	03	Colonial			
Model	01	Residential			
Grade:	C+	Average Plus			
Stories	2	2 Stories			
Exterior Wall 1	14	Wood Shingle			
Exterior Wall 2	11	Clapboard			
Roof Structure	03	Gable/Hip			
Roof Cover	03	Asph/F Gls/Cmp			
Interior Wall 1	05	Drywall			
Interior Wall 2					
Interior Floor 1	12	Hardwood			
Interior Floor 2	14	Carpet			
Heat Fuel	04	Electric			
Heat Type	07	Elec Baseboard			
AC Type	01	None			
Bedrooms	03	3 Bedrooms			
Full Baths	2				
Half Baths	0				
Extra Fixtures					
Total Rooms	6	6 Rooms			
Bath Style					
Kitchen Style					
Occupancy					
Usrflid 105					
Accessory Apt					
Foundation Alt	01	Poured Conc.			
Rms Prts					
Bath Split	20	2 Full-0 Half			

CONDO DATA			
Parcel Id		C	Owne 0.0
		B	S
Adjust Type	Code	Description	Factor%
Condo Flr			
Condo Unit			

COST / MARKET VALUATION	
Building Value New	536,428
Year Built	1981
Effective Year Built	2001
Depreciation Code	G
Remodel Rating	
Year Remodeled	
Depreciation %	14
Functional Obsol	0
External Obsol	0
Trend Factor	1
Condition	
Condition %	
Percent Good	86
RCNLD	461,300
Dep % Ovr	
Dep Ovr Comment	
Misc Imp Ovr	
Misc Imp Ovr Comment	
Cost to Cure Ovr	
Cost to Cure Ovr Comment	



OB - OUTBUILDING & YARD ITEMS(L) / XF - BUILDING EXTRA FEATURES(B)										
Code	Description	L/B	Units	Unit Price	Yr Blt	Cond. Cd	% Gd	Grade	Grade Adj.	Appr. Value
BFA1	Bsmt Fin-Goo	B	800	32.56	2003		86		0.00	22,400
WDC	Wood Decking	L	323	20.00	1998		58		0.00	3,700
PAT2	Patio-Good	L	176	9.94	1998		79		0.00	1,600
GAR	Attached Gara	B	576	40.00	2003		86		0.00	17,600
BMT	Basement-Unfi	B	864	26.01	2003		86		0.00	20,600
PAT1	Patio- Average	L	336	5.89	1981		62		0.00	1,200

BUILDING SUB-AREA SUMMARY SECTION						
Code	Description	Living Area	Floor Area	Eff Area	Unit Cost	Undeprec Value
BAS	First Floor	1,072	1,072	1,072	245.17	262,820
BMT	Basement Area	0	1,072	0	0.00	0
FUS	Upper Story	1,116	1,116	1,116	245.17	273,607
GAR	Attached Garage	0	576	0	0.00	0
PTO	Patio	0	512	0	0.00	0
WDK	Wood Deck	0	323	0	0.00	0
Ttl Gross Liv / Lease Area		2,188	4,671	2,188		536,427

