

| CURRENT OWNER | | TOPO | UTILITIES | STRT / ROAD | LOCATION | CURRENT ASSESSMENT | | | |
|---|--|----------------|----------------|---|-----------------|---------------------------|------|----------|----------|
| IVES, IAN E & MACKENTHUN, VIOLA 209 OLD JAIL LN BARNSTABLE MA 02630 | | 2 Above Street | 6 Septic | 3 Unpaved | 9 Rear Location | Description | Code | Assessed | Assessed |
| | | | 4 Gas | | | RESIDENTL | 1010 | 780,700 | 780,700 |
| | | | 2 Public Water | | | RES LAND | 1010 | 328,900 | 328,900 |
| SUPPLEMENTAL DATA | | | | | | Total 1,109,600 1,109,600 | | | |
| Alt Prcl ID Split Zonin BID Parcel ResExpt Q YES: #DL 1 LOT 2 #DL 2 GIS ID F_980025_2717308 | | | | Plan Ref. Land Ct# 39072-B #SR Life Estate PP STATU Assoc Pid# | | | | | |

801
 FY2024
 BARNSTABLE, MA
VISION

| RECORD OF OWNERSHIP | | BK-VOL/PAGE | SALE DATE | Q/U | V/I | SALE PRIC | VC | PREVIOUS ASSESSMENTS (HISTORY) | | | | | | | |
|---------------------------------|--|-------------|-----------|------------|-----|-----------|---------|--------------------------------|------|-----------|----------|-------|---------|----------|---------|
| IVES, IAN E & MACKENTHUN, VIOLA | | C194296 | 0 | 05-19-2011 | Q | I | 485,000 | 00 | Year | Code | Assessed | Year | Code | Assessed | |
| CAMPBELL, DOUGLAS JAMES | | C167875 | 0 | 01-08-2003 | U | I | 1 | 1A | 2023 | 1010 | 704,100 | 2022 | 1010 | 597,000 | |
| CAMPBELL, DOUGLAS & DEBORAH | | C122398 | 0 | 01-15-1991 | Q | I | 225,000 | U | | 1010 | 328,200 | | 1010 | 217,400 | |
| RICKER, LINWOOD D & CHARLOTTE | | C91439 | 0 | 04-08-1983 | Q | V | 26,000 | U | | | | | 1010 | 44,500 | |
| Total | | | | | | | | | | 1,032,300 | | Total | 814,400 | Total | 745,600 |

| EXEMPTIONS | | | | OTHER ASSESSMENTS | | | |
|------------|------|-----------------------|--------|-------------------|-------------|--------|--------|
| Year | Code | Description | Amount | Code | Description | Number | Amount |
| 2013 | 5C | RESIDENTIAL EXEMPTION | 0.00 | | | | |
| Total | | | 0.00 | | | | |

This signature acknowledges a visit by a Data Collector or Assessor

| ASSESSING NEIGHBORHOOD | | | |
|------------------------|-----------|---|---------|
| Nbhd | Nbhd Name | B | Tracing |
| 0108 | | | BARNS |

| APPRAISED VALUE SUMMARY | |
|-------------------------------|-----------|
| Appraised Bldg. Value (Card) | 665,100 |
| Appraised Xf (B) Value (Bldg) | 71,100 |
| Appraised Ob (B) Value (Bldg) | 44,500 |
| Appraised Land Value (Bldg) | 328,900 |
| Special Land Value | 0 |
| Total Appraised Parcel Value | 1,109,600 |
| Valuation Method | C |
| Total Appraised Parcel Value | 1,109,600 |

| NOTES | | | | | | | |
|-------|--|--|--|--|--|--|--|
| | | | | | | | |

| BUILDING PERMIT RECORD | | | | | | | | | VISIT / CHANGE HISTORY | | | | | |
|------------------------|------------|------|----------------|---------|------------|--------|------------|-------------------------------|------------------------|----|------|----|----|-----------------------|
| Permit Id | Issue Date | Type | Description | Amount | Insp Date | % Comp | Date Comp | Comments | Date | Id | Type | Is | Cd | Purpost/Result |
| EXPR-22-2 | 02-22-2022 | 835 | Sid/Wind/Roof/ | 2,000 | 06-30-2022 | 100 | 06-30-2022 | RESIDENTIAL WEATHERIZA | 08-16-2022 | CK | 03 | | 16 | In Office Review |
| BLDR-21-78 | 06-11-2021 | 839 | Solar Panel-Re | 39,418 | 06-30-2022 | 100 | 06-30-2022 | System consists of 41 320-wat | 05-12-2020 | DM | | | FR | Field Review |
| 201402316 | 05-27-2014 | AD | Addition | 350,000 | 12-01-2014 | 100 | 06-30-2015 | AD GUEST BDRM, 1ST&2ND | 03-25-2015 | JR | 03 | | 03 | Cycl Insp Comp |
| 201205841 | 09-26-2012 | IN | Insulation | 3,000 | 06-30-2013 | 100 | 06-30-2013 | IN WEATHERIZE, AIR SEAL | 01-30-2015 | MW | 01 | | 02 | Bldg Permit Completed |
| 201104287 | 08-10-2011 | NR | New Roof | 5,800 | 06-30-2012 | 100 | 06-30-2012 | NR REROOF-STRP OLD | 01-30-2015 | SR | 02 | | 03 | Cycl Insp Comp |
| 68282 | 04-22-2003 | OT | Other | 0 | 11-28-2011 | 100 | 06-30-2012 | POOL HEATER | 08-02-2012 | TR | 22 | | 22 | Change of Address |
| B34454 | 07-01-1991 | AD | Addition | 21,500 | 01-15-1992 | 100 | 06-30-1992 | BA ADD'N | 07-30-2012 | GC | 03 | | 16 | In Office Review |

| LAND LINE VALUATION SECTION | | | | | | | | | | | | | | | | |
|-----------------------------|----------|----------------|------|----|------------|---------------|------------------------|---------|------------|-------|-------|-----------|------------------|--------------------|------------|------------|
| B | Use Code | Description | Zone | LA | Land Units | Unit Price | Size Adj | AC Disc | Site Index | Cond. | Nbhd. | Nbhd. Adj | Notes | Location Adjustmen | Adj Unit P | Land Value |
| 1 | 1010 | Single Fam M-0 | RG | 1 | 1.000 | AC 176,344.00 | 1.00000 | 1.0000 | 5 | 1.00 | 0108 | 1.700 | | 1.0000 | 299,784.8 | 299,800 |
| 1 | 1010 | Single Fam M-0 | RG | 1 | 1.200 | AC 14,250.00 | 1.00000 | 1.0000 | 0 | 1.00 | 0108 | 1.700 | | 1.0000 | 24,225 | 29,100 |
| Total Card Land Units | | | | | 2.20 | AC | Parcel Total Land Area | | | | | 2.20 | Total Land Value | | | 328,900 |

| CONSTRUCTION DETAIL | | | CONSTRUCTION DETAIL (CONTINUED) | | |
|---------------------|----|----------------|---------------------------------|----|-------------|
| Element | Cd | Description | Element | Cd | Description |
| Style | 04 | Cape Cod | | | |
| Model | 01 | Residential | | | |
| Grade: | C+ | Average Plus | | | |
| Stories | 2 | 2 Stories | | | |
| Exterior Wall 1 | 14 | Wood Shingle | | | |
| Exterior Wall 2 | 11 | Clapboard | | | |
| Roof Structure | 03 | Gable/Hip | | | |
| Roof Cover | 03 | Asph/F Gls/Cmp | | | |
| Interior Wall 1 | 05 | Drywall | | | |
| Interior Wall 2 | | | | | |
| Interior Floor 1 | 12 | Hardwood | | | |
| Interior Floor 2 | 14 | Carpet | | | |
| Heat Fuel | 02 | Oil | | | |
| Heat Type | 05 | Hot Water | | | |
| AC Type | 01 | None | | | |
| Bedrooms | 03 | 3 Bedrooms | | | |
| Full Baths | 3 | | | | |
| Half Baths | 1 | | | | |
| Extra Fixtures | | | | | |
| Total Rooms | 6 | | | | |
| Bath Style | | | | | |
| Kitchen Style | | | | | |
| Occupancy | | | | | |
| Usrflid 105 | | | | | |
| Accessory Apt | | | | | |
| Foundation Alt | 01 | Poured Conc. | | | |
| Rms Prts | | | | | |
| Bath Split | 31 | 3 Full-1 Half | | | |

| CONDO DATA | | | | |
|-------------|------|-------------|---------|----------|
| Parcel Id | | C | | Owne 0.0 |
| | | | B | S |
| Adjust Type | Code | Description | Factor% | |
| Condo Flr | | | | |
| Condo Unit | | | | |

| COST / MARKET VALUATION | |
|--------------------------|---------|
| Building Value New | 764,475 |
| Year Built | 1983 |
| Effective Year Built | 2002 |
| Depreciation Code | G |
| Remodel Rating | |
| Year Remodeled | |
| Depreciation % | 13 |
| Functional Obsol | 0 |
| External Obsol | 0 |
| Trend Factor | 1 |
| Condition | |
| Condition % | |
| Percent Good | 87 |
| RCNLD | 665,100 |
| Dep % Ovr | |
| Dep Ovr Comment | |
| Misc Imp Ovr | |
| Misc Imp Ovr Comment | |
| Cost to Cure Ovr | |
| Cost to Cure Ovr Comment | |

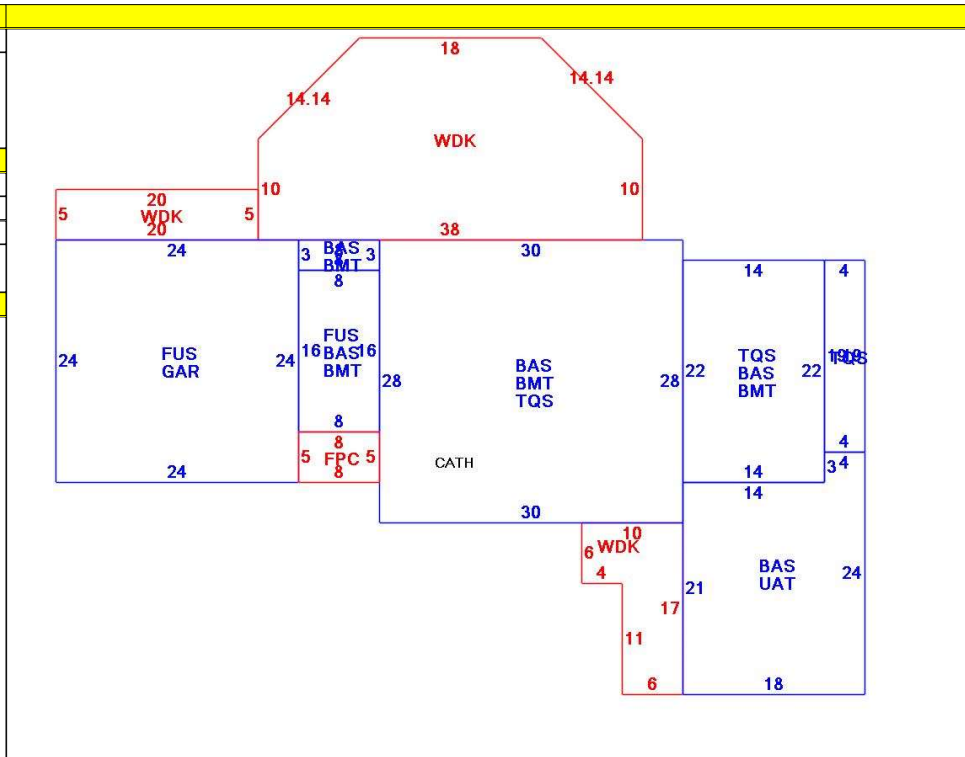

OB - OUTBUILDING & YARD ITEMS(L) / XF - BUILDING EXTRA FEATURES(B)

| Code | Description | L/B | Units | Unit Price | Yr Blt | Cond. Cd | % Gd | Grade | Grade Adj. | Appr. Value |
|------|-----------------|-----|-------|------------|--------|----------|------|-------|------------|-------------|
| FPL3 | Fireplace 2 sto | B | 1 | 7000.00 | 2004 | | 87 | | 0.00 | 6,100 |
| BFA | Bsmt Fin-Avg | B | 1,150 | 17.36 | 2004 | | 87 | | 0.00 | 17,400 |
| SPL2 | Pool Vinyl | L | 608 | 55.00 | 2003 | | 68 | 00 | 1.00 | 22,000 |
| WDC | Wood Decking | L | 100 | 20.00 | 1999 | | 60 | | 0.00 | 2,100 |
| FOPC | Open Prch-roo | B | 40 | 55.00 | 2004 | | 87 | | 0.00 | 2,100 |
| GAR | Attached Gara | B | 576 | 40.00 | 2004 | | 87 | | 0.00 | 17,800 |
| BMT | Basement-Unfi | B | 1,300 | 26.01 | 2004 | | 87 | | 0.00 | 27,700 |
| WDC | Wood Deck w/ | L | 660 | 18.00 | 1999 | | 60 | | 0.00 | 6,500 |
| WDC | Wood Deck w/ | L | 450 | 18.00 | 2003 | | 68 | | 0.00 | 5,200 |
| SPH2 | Pool Heater 50 | L | 1 | 3081.00 | 2003 | | 68 | | 0.00 | 2,100 |

BUILDING SUB-AREA SUMMARY SECTION

| Code | Description | Living Area | Floor Area | Eff Area | Unit Cost | Undeprec Value |
|----------------------------|------------------------|-------------|------------|----------|-----------|----------------|
| BAS | First Floor | 1,690 | 1,690 | 1,690 | 236.75 | 400,113 |
| BMT | Basement Area | 0 | 1,300 | 0 | 0.00 | 0 |
| FPC | Open Porch Conc. Floor | 0 | 40 | 0 | 0.00 | 0 |
| FUS | Upper Story | 704 | 704 | 704 | 236.75 | 166,674 |
| GAR | Attached Garage | 0 | 576 | 0 | 0.00 | 0 |
| TQS | Three Quarter Story | 796 | 1,224 | 796 | 153.97 | 188,455 |
| UAT | Attic, Unfinished | 0 | 390 | 39 | 23.68 | 9,233 |
| WDK | Wood Deck | 0 | 886 | 0 | 0.00 | 0 |
| Ttl Gross Liv / Lease Area | | 3,190 | 6,810 | 3,229 | | 764,475 |



| CURRENT OWNER | | TOPO | | UTILITIES | | STRT / ROAD | | LOCATION | | CURRENT ASSESSMENT | | | | 801 FY2024 BARNSTABLE, MA VISION | | | | | | | | | | | | |
|---|------------|------------------|--------------|-------------------------|------------------------|-------------|-----------|---|---------------|--|-------|-----------|----------|--|----------------|--------------------------------|--|-------|------|----------|------|-------|----------|-------|------|----------|
| IVES, IAN E & MACKENTHUN, VIOLA 209 OLD JAIL LN BARNSTABLE MA 02630 | | 2 | Above Street | 6 | Septic | 3 | Unpaved | 9 | Rear Location | Description | Code | Assessed | Assessed | | | | | | | | | | | | | |
| | | | | 4 | Gas | | | | | RESIDNTL | 1010 | 780,700 | 780,700 | | | | | | | | | | | | | |
| | | | | 2 | Public Water | | | | | RES LAND | 1010 | 328,900 | 328,900 | | | | | | | | | | | | | |
| SUPPLEMENTAL DATA | | | | | | | | | | Total | | | | 1,109,600 | 1,109,600 | | | | | | | | | | | |
| Alt Prcl ID | | Split Zonin | | Plan Ref. | | Land Ct# | | 39072-B | | | | | | | | | | | | | | | | | | |
| BID Parcel | | ResExpt Q | | YES: | | Life Estate | | PP STATU | | | | | | | | | | | | | | | | | | |
| #DL 1 | | LOT 2 | | | | | | | | | | | | | | | | | | | | | | | | |
| #DL 2 | | | | | | | | | | | | | | | | | | | | | | | | | | |
| GIS ID | | F_980025_2717308 | | Assoc Pid# | | | | | | | | | | | | | | | | | | | | | | |
| RECORD OF OWNERSHIP | | | | BK-VOL/PAGE | | SALE DATE | | Q/U | | V/I | | SALE PRIC | | VC | | PREVIOUS ASSESSMENTS (HISTORY) | | | | | | | | | | |
| | | | | | | | | | | | | | | | | | | Year | Code | Assessed | Year | Code | Assessed | Year | Code | Assessed |
| | | | | | | | | | | | | | | | | | | 2023 | 1010 | 704,100 | 2022 | 1010 | 597,000 | 2021 | 1010 | 470,100 |
| | | | | | | | | | | | | | | | | | | | 1010 | 328,200 | | 1010 | 217,400 | | 1010 | 231,000 |
| | | | | | | | | | | | | | | | | | | | | | | | | | 1010 | 44,500 |
| | | | | | | | | | | | | | | | | | | Total | | Total | | Total | | Total | | 745,600 |
| EXEMPTIONS | | | | OTHER ASSESSMENTS | | | | This signature acknowledges a visit by a Data Collector or Assessor | | | | | | | | | | | | | | | | | | |
| Year | Code | Description | | Amount | Code | Description | Number | Amount | Comm Int | | | | | | | | | | | | | | | | | |
| | | | | | | | | | | | | | | | | | | | | | | | | | | |
| | | | | Total | | | | | | | | | | | | | | | | | | | | | | |
| ASSESSING NEIGHBORHOOD | | | | APPRAISED VALUE SUMMARY | | | | | | | | | | | | | | | | | | | | | | |
| Nbhd | | Nbhd Name | | B | | Tracing | | Batch | | Appraised Bldg. Value (Card) 665,100 | | | | | | | | | | | | | | | | |
| 0108 | | | | | | | | BARNS | | Appraised Xf (B) Value (Bldg) 71,100 | | | | | | | | | | | | | | | | |
| | | | | | | | | | | Appraised Ob (B) Value (Bldg) 44,500 | | | | | | | | | | | | | | | | |
| | | | | | | | | | | Appraised Land Value (Bldg) 328,900 | | | | | | | | | | | | | | | | |
| | | | | | | | | | | Special Land Value 0 | | | | | | | | | | | | | | | | |
| | | | | | | | | | | Total Appraised Parcel Value 1,109,600 | | | | | | | | | | | | | | | | |
| | | | | | | | | | | Valuation Method C | | | | | | | | | | | | | | | | |
| | | | | | | | | | | Total Appraised Parcel Value 1,109,600 | | | | | | | | | | | | | | | | |
| BUILDING PERMIT RECORD | | | | | | | | | | VISIT / CHANGE HISTORY | | | | | | | | | | | | | | | | |
| Permit Id | Issue Date | Type | Description | Amount | Insp Date | % Comp | Date Comp | Comments | | Date | Id | Type | Is | Cd | Purpost/Result | | | | | | | | | | | |
| | | | | | | | | | | | | | | | | | | | | | | | | | | |
| LAND LINE VALUATION SECTION | | | | | | | | | | | | | | | | | | | | | | | | | | |
| B | Use Code | Description | Zone | LA | Land Units | Unit Price | Size Adj | AC Disc | Site Index | Cond. | Nbhd. | Nbhd. Adj | Notes | Location Adjustmen | Adj Unit P | Land Value | | | | | | | | | | |
| | | | | | | | | | | | | | | | | | | | | | | | | | | |
| Total Card Land Units | | | | | Parcel Total Land Area | | | | | Total Land Value | | | | | | | | | | | | | | | | |

