

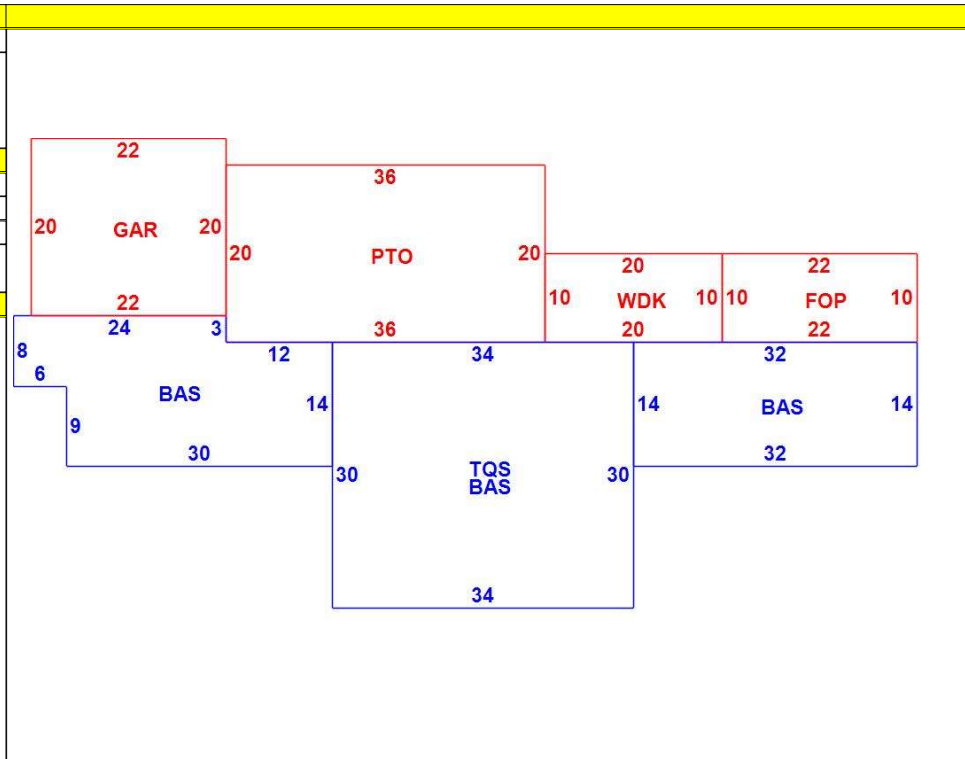

CONSTRUCTION DETAIL			CONSTRUCTION DETAIL (CONTINUED)		
Element	Cd	Description	Element	Cd	Description
Style	04	Cape Cod			
Model	01	Residential			
Grade:	C+	Average Plus			
Stories	2	2 Stories			
Exterior Wall 1	14	Wood Shingle			
Exterior Wall 2					
RooF Structure	03	Gable/Hip			
RooF Cover	03	Asph/F Gls/Cmp			
Interior Wall 1	05	Drywall			
Interior Wall 2					
Interior Floor 1	12	Hardwood			
Interior Floor 2	14	Carpet			
Heat Fuel	03	Gas			
Heat Type	05	Hot Water			
AC Type	03	Central			
Bedrooms	04	4 Bedrooms			
Full Baths	4				
Half Baths	1				
Extra Fixtures					
Total Rooms	8	8 Rooms			
Bath Style					
Kitchen Style					
Occupancy					
Usrflid 105	2				
Accessory Apt					
Foundation Alt	10	Brick Ftgs			
Rms Prts					
Bath Split	41	4 Full-1 Half			
			<b>CONDO DATA</b>		
			Parcel Id	C	Owne 0.0
			Adjust Type Code Description Factor%		
			Condo Flr		
			Condo Unit		
			<b>COST / MARKET VALUATION</b>		
			Building Value New		692,775
			Year Built		1900
			Effective Year Built		1979
			Depreciation Code		A
			Remodel Rating		
			Year Remodeled		
			Depreciation %		31
			Functional Obsol		0
			External Obsol		0
			Trend Factor		1
			Condition		
			Condition %		
			Percent Good		69
			RCNLD		478,000
			Dep % Ovr		
			Dep Ovr Comment		
			Misc Imp Ovr		
			Misc Imp Ovr Comment		
			Cost to Cure Ovr		
			Cost to Cure Ovr Comment		



OB - OUTBUILDING & YARD ITEMS(L) / XF - BUILDING EXTRA FEATURES(B)										
Code	Description	L/B	Units	Unit Price	Yr Blt	Cond. Cd	% Gd	Grade	Grade Adj.	Appr. Value
FPL2	Fireplace 1.5 s	B	4	6000.00	1979		69		0.00	16,600
SPL1	Pool-Concrete	L	760	100.00	1988		38	00	1.00	27,000
WDC	Wood Decking	L	200	20.00	1986		34		0.00	1,600
PAT1	Patio- Average	L	720	5.89	1986		67		0.00	2,700
FOP	Open Porch-ro	B	220	55.00	1979		69		0.00	6,600
GAR	Attached Gara	B	440	40.00	1979		69		0.00	11,800
FPLG	Gas Fireplace-	B	1	2500.00	1979		69		0.00	1,700
PATC	Conc Pavers	L	892	15.46	1988		69		0.00	8,700

BUILDING SUB-AREA SUMMARY SECTION						
Code	Description	Living Area	Floor Area	Eff Area	Unit Cost	Undeprec Value
BAS	First Floor	1,990	1,990	1,990	261.13	519,647
FOP	Open Porch	0	220	0	0.00	0
GAR	Attached Garage	0	440	0	0.00	0
PTO	Patio	0	720	0	0.00	0
TQS	Three Quarter Story	663	1,020	663	169.73	173,129
WDK	Wood Deck	0	200	0	0.00	0
Ttl Gross Liv / Lease Area		2,653	4,590	2,653		692,776





