

| CURRENT OWNER | | TOPO | UTILITIES | STRT / ROAD | LOCATION | CURRENT ASSESSMENT | | | | 801 FY2024 BARNSTABLE, MA VISION | |
|--|--|-------------|----------------|-------------------|--------------|--------------------|------|-----------|-----------|--|-----------|
| LLOYD, TANGLEY C TR TANGLEY C LLOYD AMENDED REV T PO BOX 336 HYANNISPORT MA 02647 | | 1 Level | 2 Public Water | 1 Paved | 1 Excel View | Description | Code | Assessed | Assessed | | |
| | | | 4 Gas | | | RESIDENTL | 1010 | 2,718,800 | 2,718,800 | | |
| | | | 6 Septic | | | RES LAND | 1010 | 2,958,900 | 2,958,900 | | |
| SUPPLEMENTAL DATA | | | | | | Total | | | | 5,677,700 | 5,677,700 |
| Alt Prcl ID | | Split Zonin | | Plan Ref. | | | | | | | |
| BID Parcel | | ResExpt Q | | Land Ct# 12327-A | | | | | | | |
| #DL 1 850-A | | | | #SR | | | | | | | |
| #DL 2 | | | | Life Estate | | | | | | | |
| GIS ID F_982920_2692419 | | | | PP STATU A:Active | | | | | | | |
| | | | | Assoc Pid# | | | | | | | |

| RECORD OF OWNERSHIP | | BK-VOL/PAGE | SALE DATE | Q/U | V/I | SALE PRIC | VC | PREVIOUS ASSESSMENTS (HISTORY) | | | | | | | | |
|-------------------------|---------|-------------|------------|-----|-----|-----------|----|--------------------------------|------|-----------|------|-----------|-----------|-------|--|-----------|
| LLOYD, TANGLEY C TR | C227589 | 0 | 09-17-2021 | U | I | 1 | 1F | Year | Code | Assessed | Year | Code | Assessed | | | |
| LLOYD, TANGLEY CAMPBELL | D114330 | 0 | 06-30-2010 | U | I | 0 | 1 | 2023 | 1010 | 2,125,000 | 2022 | 1010 | 1,962,900 | | | |
| DELANEY, TANGLEY L | D490330 | 0 | 09-01-1989 | U | I | 1 | 1F | | 1010 | 2,373,400 | | 1010 | 1,992,500 | | | |
| QUINN, TANGLEY L | C72443 | 0 | 11-17-1977 | U | V | 0 | | | | | | 1010 | 77,800 | | | |
| Total | | | | | | | | 4,498,400 | | Total | | 3,955,400 | | Total | | 3,704,700 |

| EXEMPTIONS | | | OTHER ASSESSMENTS | | | | This signature acknowledges a visit by a Data Collector or Assessor | | | | | | | | | | | |
|------------|------|-------------|-------------------|------|-------------|--------|---|----------|--|--|--|--|--|--|--|--|--|--|
| Year | Code | Description | Amount | Code | Description | Number | Amount | Comm Int | | | | | | | | | | |
| | | | | | | | | | | | | | | | | | | |
| Total | | | 0.00 | | | | | | | | | | | | | | | |

| ASSESSING NEIGHBORHOOD | | | | |
|------------------------|-----------|---|---------|-------|
| Nbhd | Nbhd Name | B | Tracing | Batch |
| 0121 | | | | HYAN |

| NOTES | | | | | | | | | | | | | |
|-------|--|--|--|--|--|--|--|--|--|--|--|--|--|
| | | | | | | | | | | | | | |

| BUILDING PERMIT RECORD | | | | | | | | | VISIT / CHANGE HISTORY | | | | | |
|------------------------|------------|------|---------------|---------|------------|--------|------------|-------------------------|------------------------|----|------|----|----|-----------------------|
| Permit Id | Issue Date | Type | Description | Amount | Insp Date | % Comp | Date Comp | Comments | Date | Id | Type | Is | Cd | Purpost/Result |
| 201207367 | 12-14-2012 | RE | Remodel | 175,000 | 06-06-2013 | 100 | 06-30-2014 | REMOD 3 BTHS-UPDATE KIT | 05-27-2020 | WD | | | FR | Field Review |
| 201107121 | 01-13-2012 | OT | Other | 110,000 | 06-06-2013 | 100 | 06-30-2014 | FIN 2ND FLR OVR GAR | 02-15-2018 | SR | 02 | | 03 | Cycl Insp Comp |
| 81022 | 12-03-2004 | NR | New Roof | 12,000 | 06-30-2005 | 100 | 06-30-2005 | REROOF | 12-05-2017 | MD | 22 | | 22 | Change of Address |
| 69685 | 06-24-2003 | PH | Pool Heater | | 04-29-2013 | 100 | 06-30-2013 | POOL HTR | 07-26-2016 | JR | 03 | | 16 | In Office Review |
| 67436 | 03-12-2003 | SP | Swimming Pool | 35,000 | 06-17-2004 | 100 | 01-01-2004 | GUNITE POOL W SPA | 09-04-2014 | MW | 02 | | 02 | Bldg Permit Completed |
| | | | | | | | | | 06-12-2013 | RB | 03 | | 13 | CALL BACK |
| | | | | | | | | | 05-13-2013 | RB | 03 | | 13 | CALL BACK |

| LAND LINE VALUATION SECTION | | | | | | | | | | | | | | | | | |
|-----------------------------|----------|----------------|------|----|------------|------------|------------------------|---------|------------|-------|-------|-----------|------------------|--------------------|------------|------------|-----------|
| B | Use Code | Description | Zone | LA | Land Units | Unit Price | Size Adj | AC Disc | Site Index | Cond. | Nbhd. | Nbhd. Adj | Notes | Location Adjustmen | Adj Unit P | Land Value | |
| 1 | 1010 | Single Fam M-0 | RF-1 | 4 | 0.860 | AC | 176,344.00 | 1.14768 | 1.0000 | 5 | 1.00 | 0121 | 17.000 | | 1.0000 | 3,440,577 | 2,958,900 |
| Total Card Land Units | | | | | 0.86 | AC | Parcel Total Land Area | | | | | 0.86 | Total Land Value | | | 2,958,900 | |

| CONSTRUCTION DETAIL | | | | | | CONSTRUCTION DETAIL (CONTINUED) | | | | | |
|---------------------|----|----------------|--|--|--|---------------------------------|------|-------------|--|-----------|-----|
| Element | Cd | Description | | | | Element | Cd | Description | | | |
| Style | 07 | Modern/Contemp | | | | | | | | | |
| Model | 01 | Residential | | | | | | | | | |
| Grade: | X | Exceptional | | | | | | | | | |
| Stories | 2 | 2 Stories | | | | | | | | | |
| Exterior Wall 1 | 08 | Wood on Sheath | | | | | | | | | |
| Exterior Wall 2 | | | | | | CONDO DATA | | | | | |
| Roof Structure | 03 | Gable/Hip | | | | Parcel Id | | C | | Owne | 0.0 |
| Roof Cover | 10 | Wood Shingle | | | | | | B | | S | |
| Interior Wall 1 | 05 | Drywall | | | | Adjust Type | Code | Description | | Factor% | |
| Interior Wall 2 | | | | | | Condo Flr | | | | | |
| Interior Floor 1 | 09 | Pine/Soft Wood | | | | Condo Unit | | | | | |
| Interior Floor 2 | 12 | Hardwood | | | | COST / MARKET VALUATION | | | | | |
| Heat Fuel | 03 | Gas | | | | Building Value New | | | | 2,892,523 | |
| Heat Type | 04 | Hot Air | | | | Year Built | | | | 1984 | |
| AC Type | 03 | Central | | | | Effective Year Built | | | | 1998 | |
| Bedrooms | 05 | 5 Bedrooms | | | | Depreciation Code | | | | A | |
| Full Baths | 6 | | | | | Remodel Rating | | | | | |
| Half Baths | 1 | | | | | Year Remodeled | | | | | |
| Extra Fixtures | | | | | | Depreciation % | | | | 16 | |
| Total Rooms | 8 | 8 Rooms | | | | Functional Obsol | | | | 0 | |
| Bath Style | | | | | | External Obsol | | | | 0 | |
| Kitchen Style | | | | | | Trend Factor | | | | 1 | |
| Occupancy | | | | | | Condition | | | | | |
| Usrflid 105 | | | | | | Condition % | | | | | |
| Accessory Apt | | | | | | Percent Good | | | | 84 | |
| Foundation Alt | 01 | Poured Conc. | | | | RCNLND | | | | 2,429,700 | |
| Rms Prts | | | | | | Dep % Ovr | | | | | |
| Bath Split | 61 | 6 Full-1 Half | | | | Dep Ovr Comment | | | | | |
| | | | | | | Misc Imp Ovr | | | | | |
| | | | | | | Misc Imp Ovr Comment | | | | | |
| | | | | | | Cost to Cure Ovr | | | | | |
| | | | | | | Cost to Cure Ovr Comment | | | | | |

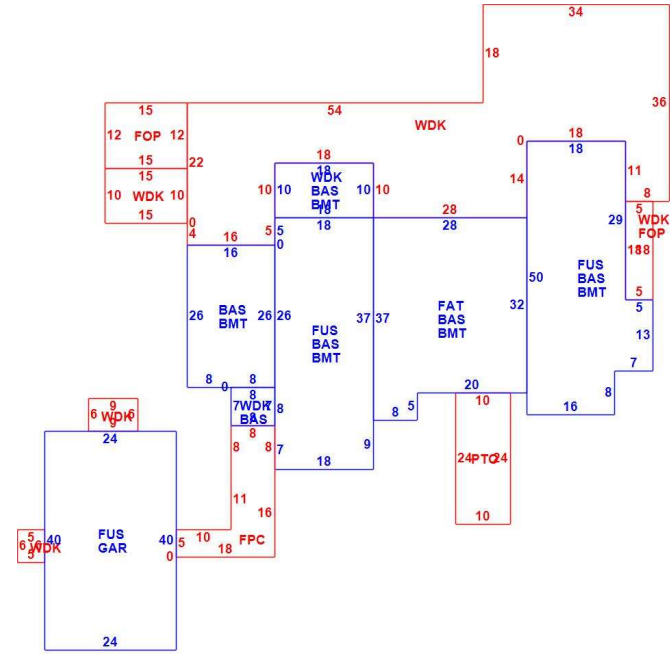

11/12/2014

| CURRENT OWNER | | TOPO | UTILITIES | STRT / ROAD | LOCATION | CURRENT ASSESSMENT | | | |
|--|--|---------|----------------|-------------|--------------|--------------------|------|-----------|-----------|
| LLOYD, TANGLEY C TR TANGLEY C LLOYD AMENDED REV T PO BOX 336 HYANNISPORT MA 02647 | | 1 Level | 2 Public Water | 1 Paved | 1 Excel View | Description | Code | Assessed | Assessed |
| | | | 4 Gas | | | RESIDNTL | 1010 | 2,718,800 | 2,718,800 |
| | | | 6 Septic | | | RES LAND | 1010 | 2,958,900 | 2,958,900 |
| SUPPLEMENTAL DATA | | | | | | | | | |
| Alt Prcl ID | | | | | Plan Ref. | | | | |
| Split Zonin | | | | | Land Ct# | 12327-A | | | |
| BID Parcel | | | | | #SR | | | | |
| ResExpt Q | | | | | Life Estate | | | | |
| #DL 1 850-A | | | | | PP STATU | A:Active | | | |
| #DL 2 | | | | | Assoc Pid# | | | | |
| GIS ID F_982920_2692419 | | | | | | | | | |
| | | | | | | Total | | 5,677,700 | 5,677,700 |

801
FY2024
BARNSTABLE, MA

VISION

| RECORD OF OWNERSHIP | | | | | | | BK-VOL/PAGE | SALE DATE | Q/U | V/I | SALE PRIC | VC | PREVIOUS ASSESSMENTS (HISTORY) | | | | | | | | | |
|---------------------|--|--|--|--|--|--|-------------|-----------|-----|-----|-----------|----|--------------------------------|-------|------|-----------|-------|------|-----------|-------|------|-----------|
| | | | | | | | | | | | | | | Year | Code | Assessed | Year | Code | Assessed | Year | Code | Assessed |
| | | | | | | | | | | | | | | 2023 | 1010 | 2,125,000 | 2022 | 1010 | 1,962,900 | 2021 | 1010 | 1,634,400 |
| | | | | | | | | | | | | | | | 1010 | 2,373,400 | | 1010 | 1,992,500 | | 1010 | 1,992,500 |
| | | | | | | | | | | | | | | | | | | | | | | 77,800 |
| | | | | | | | | | | | | | | Total | | 4,498,400 | Total | | 3,955,400 | Total | | 3,704,700 |

| EXEMPTIONS | | | | OTHER ASSESSMENTS | | | | This signature acknowledges a visit by a Data Collector or Assessor | | | | |
|------------|------|-------------|--------|-------------------|-------------|--------|--------|---|--|--|--|--|
| Year | Code | Description | Amount | Code | Description | Number | Amount | Comm Int | | | | |
| | | | | | | | | | | | | |
| Total | | | | | | | | | | | | |

| ASSESSING NEIGHBORHOOD | | | | | |
|------------------------|-----------|---|---------|-------|--|
| Nbhd | Nbhd Name | B | Tracing | Batch | |
| 0121 | | | | HYAN | |

| NOTES | | | | | | APPRAISED VALUE SUMMARY | | | | | |
|-------|--|--|--|--|--|-------------------------------|--|--|--|--|-----------|
| | | | | | | Appraised Bldg. Value (Card) | | | | | 2,429,700 |
| | | | | | | Appraised Xf (B) Value (Bldg) | | | | | 211,300 |
| | | | | | | Appraised Ob (B) Value (Bldg) | | | | | 77,800 |
| | | | | | | Appraised Land Value (Bldg) | | | | | 2,958,900 |
| | | | | | | Special Land Value | | | | | 0 |
| | | | | | | Total Appraised Parcel Value | | | | | 5,677,700 |
| | | | | | | Valuation Method | | | | | C |
| | | | | | | Total Appraised Parcel Value | | | | | 5,677,700 |

| BUILDING PERMIT RECORD | | | | | | | | | | | VISIT / CHANGE HISTORY | | | | | |
|------------------------|------------|------|-------------|--------|-----------|--------|-----------|----------|--|--|------------------------|----|------|----|----|----------------|
| Permit Id | Issue Date | Type | Description | Amount | Insp Date | % Comp | Date Comp | Comments | | | Date | Id | Type | Is | Cd | Purpost/Result |
| | | | | | | | | | | | | | | | | |

| LAND LINE VALUATION SECTION | | | | | | | | | | | | | | | | | | |
|-----------------------------|----------|-------------|------|----|------------------------|------------|----------|---------|------------|------------------|-------|-----------|-------|--|--|--------------------|------------|------------|
| B | Use Code | Description | Zone | LA | Land Units | Unit Price | Size Adj | AC Disc | Site Index | Cond. | Nbhd. | Nbhd. Adj | Notes | | | Location Adjustmen | Adj Unit P | Land Value |
| | | | | | | | | | | | | | | | | | | |
| Total Card Land Units | | | | | Parcel Total Land Area | | | | | Total Land Value | | | | | | | | |

| CONSTRUCTION DETAIL | | | | | | CONSTRUCTION DETAIL (CONTINUED) | | | | | |
|---|---------------|----------------|------------|------------|-----------|---------------------------------|------|-------------|------------|-------------|-----|
| Element | Cd | Description | | | | Element | Cd | Description | | | |
| Style | 07 | Modern/Contemp | | | | | | | | | |
| Model | 01 | Residential | | | | | | | | | |
| Grade: | X | Exceptional | | | | | | | | | |
| Stories | 2 | 2 Stories | | | | | | | | | |
| Exterior Wall 1 | 08 | Wood on Sheath | | | | CONDO DATA | | | | | |
| Exterior Wall 2 | | | | | | Parcel Id | | C | | Ownr | 0.0 |
| Roof Structure | 03 | Gable/Hip | | | | | | | B | | S |
| Roof Cover | 10 | Wood Shingle | | | | Adjust Type | Code | Description | | Factor% | |
| Interior Wall 1 | 05 | Drywall | | | | Condo Flr | | | | | |
| Interior Wall 2 | | | | | | Condo Unit | | | | | |
| Interior Floor 1 | 09 | Pine/Soft Wood | | | | COST / MARKET VALUATION | | | | | |
| Interior Floor 2 | 12 | Hardwood | | | | Building Value New | | | | | |
| Heat Fuel | 03 | Gas | | | | Year Built | | | | | |
| Heat Type | 04 | Hot Air | | | | Effective Year Built | | | | | |
| AC Type | 03 | Central | | | | Depreciation Code | | | | | |
| Bedrooms | 05 | 5 Bedrooms | | | | Remodel Rating | | | | | |
| Full Baths | 6 | | | | | Year Remodeled | | | | | |
| Half Baths | 1 | | | | | Depreciation % | | | | | |
| Extra Fixtures | | | | | | Functional Obsol | | | | | |
| Total Rooms | 8 | 8 Rooms | | | | External Obsol | | | | | |
| Bath Style | | | | | | Trend Factor | | | | | |
| Kitchen Style | | | | | | Condition | | | | | |
| Occupancy | | | | | | Condition % | | | | | |
| Usrflid 105 | | | | | | Percent Good | | | | | |
| Accessory Apt | | | | | | RCNLD | | | | | |
| Foundation Alt | 01 | Poured Conc. | | | | Dep % Ovr | | | | | |
| Rms Prts | | | | | | Dep Ovr Comment | | | | | |
| Bath Split | 61 | 6 Full-1 Half | | | | Misc Imp Ovr | | | | | |
| | | | | | | Misc Imp Ovr Comment | | | | | |
| | | | | | | Cost to Cure Ovr | | | | | |
| | | | | | | Cost to Cure Ovr Comment | | | | | |
| OB - OUTBUILDING & YARD ITEMS(L) / XF - BUILDING EXTRA FEATURES(B) | | | | | | | | | | | |
| Code | Description | L/B | Units | Unit Price | Yr Blt | Cond. Cd | % Gd | Grade | Grade Adj. | Appr. Value | |
| PATC | Conc Pavers | L | 240 | 15.46 | 2005 | | 86 | | 0.00 | 3,400 | |
| FOPC | Open Prch-roo | B | 242 | 55.00 | 2000 | | 84 | | 0.00 | 7,900 | |
| BUILDING SUB-AREA SUMMARY SECTION | | | | | | | | | | | |
| Code | Description | Living Area | Floor Area | Eff Area | Unit Cost | Undeprec Value | | | | | |
| | | | | | | | | | | | |
| Ttl Gross Liv / Lease Area | | | | | | | | | | | |