

| CURRENT OWNER | | TOPO | UTILITIES | STRT / ROAD | LOCATION | CURRENT ASSESSMENT | | | | 801 FY2024 BARNSTABLE, MA VISION |
|---|--|---------|----------------|---|----------|--------------------|------|-----------|-----------|--|
| CARBERRY, JOHN V & MARY A TRS MARY ANNA & JOHN V CARBERRY N 56 WOODCLIFF ROAD WELLESLEY HIL MA 02481 | | 1 Level | 6 Septic | 1 Paved | | Description | Code | Assessed | Assessed | |
| | | | 4 Gas | | | RESIDNTL | 1010 | 619,100 | 619,100 | |
| | | | 2 Public Water | | | RES LAND | 1010 | 1,104,200 | 1,104,200 | |
| SUPPLEMENTAL DATA | | | | | | | | | | |
| Alt Prcl ID Split Zonin BID Parcel ResExpt Q #DL 1 #DL 2 GIS ID F_982612_2693714 | | | | Plan Ref. Land Ct# #SR Life Estate PP STATU Assoc Pid# | | Total | | 1,723,300 | 1,723,300 | |

| RECORD OF OWNERSHIP | | BK-VOL/PAGE | SALE DATE | Q/U | V/I | SALE PRIC | VC | PREVIOUS ASSESSMENTS (HISTORY) | | | | | |
|-----------------------------------|--|-------------|------------|-----|-----|-----------|----|--------------------------------|------|-----------|-------|------|-----------|
| CARBERRY, JOHN V & MARY A TRS | | 32997 0286 | 06-18-2020 | U | I | 100 | 1F | Year | Code | Assessed | Year | Code | Assessed |
| CARBERRY, JOHN V & MARY A | | 8622 0041 | 06-15-1993 | Q | I | 385,000 | U | 2023 | 1010 | 526,800 | 2022 | 1010 | 429,100 |
| CHAPLIN, JAMES C IV & CAROLE | | 8622 0039 | 06-15-1993 | U | I | 1 | A | | 1010 | 890,700 | | 1010 | 785,500 |
| CHAPLIN, GRETCHEN M B & JAMES & C | | 6052 0017 | 12-07-1987 | U | I | 1 | A | Total | | 1,417,500 | Total | | 1,214,600 |
| | | | | | | | | Total | | 1,173,800 | Total | | 1,173,800 |

| EXEMPTIONS | | | OTHER ASSESSMENTS | | | | APPRAISED VALUE SUMMARY | | | | | |
|------------|------|-------------|-------------------|------|-------------|--------|-------------------------|--------------------------------------|---|--|--|--|
| Year | Code | Description | Amount | Code | Description | Number | Amount | Comm Int | This signature acknowledges a visit by a Data Collector or Assessor | | | |
| | | | | | | | | | Appraised Bldg. Value (Card) 570,100 | | | |
| Total | | | 0.00 | | | | | Appraised Xf (B) Value (Bldg) 40,400 | | | | |

| ASSESSING NEIGHBORHOOD | | | |
|------------------------|-----------|---|------------|
| Nbhd | Nbhd Name | B | Tracing |
| 0116 | | | Batch HYAN |

| NOTES | | | | | | | | | | |
|------------------------------|--|--|--|--|--|--|--|-----------|--|--|
| | | | | | | | | | | |
| Total Appraised Parcel Value | | | | | | | | 1,723,300 | | |

| BUILDING PERMIT RECORD | | | | | | | | | VISIT / CHANGE HISTORY | | | | | |
|------------------------|------------|------|-------------|---------|------------|--------|------------|-----------|------------------------|----|------|----|----|----------------------------|
| Permit Id | Issue Date | Type | Description | Amount | Insp Date | % Comp | Date Comp | Comments | Date | Id | Type | Is | Cd | Purpost/Result |
| 200706160 | 10-19-2007 | RE | Remodel | 150,000 | 04-18-2008 | 100 | 06-30-2008 | INTERIOR | 05-27-2020 | WD | | | FR | Field Review |
| 18924 | 10-30-1996 | RE | Remodel | 1,000 | 08-25-1997 | 100 | 01-01-1997 | install c | 10-23-2017 | SR | 02 | | 03 | Cycl Insp Comp |
| B36589 | 04-01-1994 | WD | Wood Deck | 5,000 | 01-15-1995 | 100 | | HP DECK | 04-25-2008 | JG | 03 | | 16 | In Office Review |
| | | | | | | | | | 04-18-2008 | MK | 01 | | 00 | Meas/Listed-Interior Acces |
| | | | | | | | | | 10-24-2000 | MF | 01 | | 00 | Meas/Listed-Interior Acces |
| | | | | | | | | | 08-25-1997 | LK | 01 | | 00 | Meas/Listed-Interior Acces |

| LAND LINE VALUATION SECTION | | | | | | | | | | | | | | | | |
|-----------------------------|----------|----------------|------|----|------------|------------|------------------------|---------|------------|-------|-------|-----------|------------------|--------------------|------------|------------|
| B | Use Code | Description | Zone | LA | Land Units | Unit Price | Size Adj | AC Disc | Site Index | Cond. | Nbhd. | Nbhd. Adj | Notes | Location Adjustmen | Adj Unit P | Land Value |
| 1 | 1010 | Single Fam M-0 | RF-1 | 4 | 0.450 AC | 176,344.00 | 1.95982 | 1.0000 | 5 | 1.00 | 0116 | 7.100 | | 1.0000 | 2,453,773 | 1,104,200 |
| Total Card Land Units | | | | | 0.45 | AC | Parcel Total Land Area | | | | | 0.45 | Total Land Value | | | 1,104,200 |

| CONSTRUCTION DETAIL | | | CONSTRUCTION DETAIL (CONTINUED) | | |
|---------------------|----|----------------|---------------------------------|----|-------------|
| Element | Cd | Description | Element | Cd | Description |
| Style | 03 | Colonial | | | |
| Model | 01 | Residential | | | |
| Grade: | C+ | Average Plus | | | |
| Stories | 2 | 2 Stories | | | |
| Exterior Wall 1 | 14 | Wood Shingle | | | |
| Exterior Wall 2 | | | | | |
| RooF Structure | 07 | Gambrel | | | |
| RooF Cover | 03 | Asph/F Gls/Cmp | | | |
| Interior Wall 1 | 03 | Plastered | | | |
| Interior Wall 2 | | | | | |
| Interior Floor 1 | 12 | Hardwood | | | |
| Interior Floor 2 | | | | | |
| Heat Fuel | 02 | Oil | | | |
| Heat Type | 06 | Steam | | | |
| AC Type | 03 | Central | | | |
| Bedrooms | 05 | 5 Bedrooms | | | |
| Full Baths | 3 | | | | |
| Half Baths | 1 | | | | |
| Extra Fixtures | | | | | |
| Total Rooms | 9 | 9 Rooms | | | |
| Bath Style | | | | | |
| Kitchen Style | | | | | |
| Occupancy | | | | | |
| Usrflid 105 | | | | | |
| Accessory Apt | | | | | |
| Foundation Alt | 02 | Conc. Block | | | |
| Rms Prts | | | | | |
| Bath Split | 31 | 3 Full-1 Half | | | |

| CONDO DATA | | | | |
|-------------|------|-------------|---------|----------|
| Parcel Id | | C | | Owne 0.0 |
| | | | B | S |
| Adjust Type | Code | Description | Factor% | |
| Condo Flr | | | | |
| Condo Unit | | | | |

| COST / MARKET VALUATION | |
|--------------------------|---------|
| Building Value New | 740,409 |
| Year Built | 1930 |
| Effective Year Built | 1989 |
| Depreciation Code | VG |
| Remodel Rating | |
| Year Remodeled | |
| Depreciation % | 23 |
| Functional Obsol | 0 |
| External Obsol | 0 |
| Trend Factor | 1 |
| Condition | |
| Condition % | |
| Percent Good | 77 |
| RCNLD | 570,100 |
| Dep % Ovr | |
| Dep Ovr Comment | |
| Misc Imp Ovr | |
| Misc Imp Ovr Comment | |
| Cost to Cure Ovr | |
| Cost to Cure Ovr Comment | |

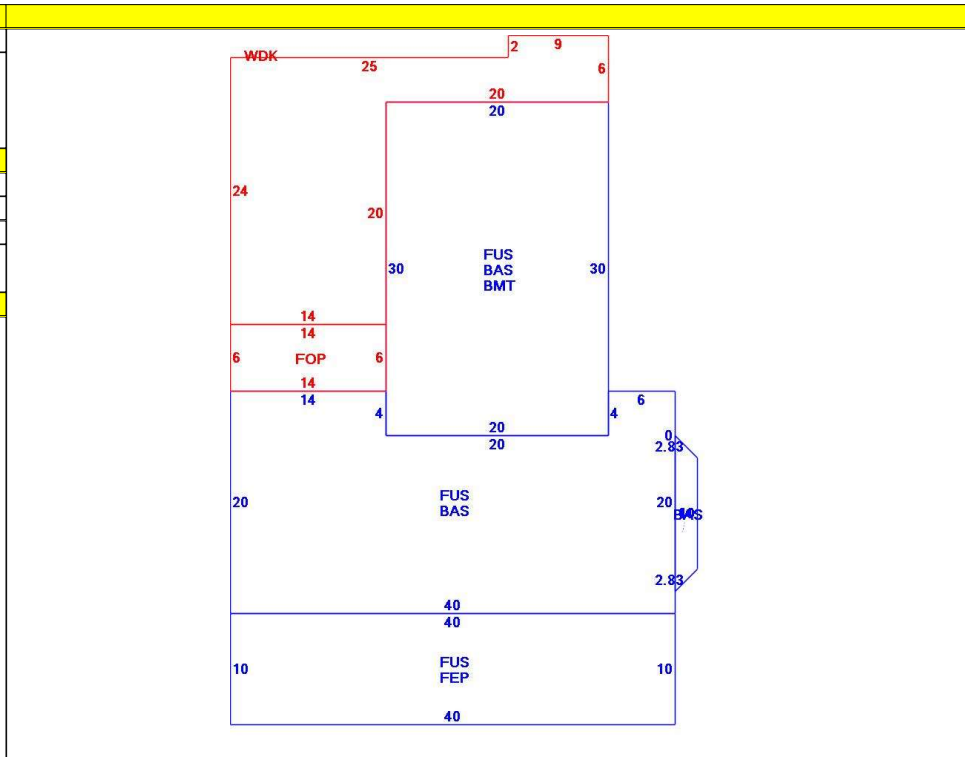

| OB - OUTBUILDING & YARD ITEMS(L) / XF - BUILDING EXTRA FEATURES(B) | | | | | | | | | | |
|--|-----------------|-----|-------|------------|--------|----------|------|-------|------------|-------------|
| Code | Description | L/B | Units | Unit Price | Yr Blt | Cond. Cd | % Gd | Grade | Grade Adj. | Appr. Value |
| FPL3 | Fireplace 2 sto | B | 1 | 7000.00 | 1989 | | 77 | | 0.00 | 5,400 |
| FGR3 | Garage-Good- | L | 264 | 60.00 | 1940 | | 21 | 00 | 1.00 | 3,300 |
| WDC | Wood Decking | L | 434 | 20.00 | 2001 | | 64 | | 0.00 | 5,300 |
| FOP | Open Porch-ro | B | 84 | 55.00 | 1989 | | 77 | | 0.00 | 3,800 |
| FEP | Enclosed porc | B | 400 | 70.00 | 1989 | | 77 | | 0.00 | 16,500 |
| BMT | Basement-Unfi | B | 600 | 26.01 | 1989 | | 77 | | 0.00 | 14,700 |

| BUILDING SUB-AREA SUMMARY SECTION | | | | | | |
|-----------------------------------|----------------|-------------|------------|----------|-----------|----------------|
| Code | Description | Living Area | Floor Area | Eff Area | Unit Cost | Undeprec Value |
| BAS | First Floor | 1,344 | 1,344 | 1,344 | 241.65 | 324,775 |
| BMT | Basement Area | 0 | 600 | 0 | 0.00 | 0 |
| FEP | Enclosed Porch | 0 | 400 | 0 | 0.00 | 0 |
| FOP | Open Porch | 0 | 84 | 0 | 0.00 | 0 |
| FUS | Upper Story | 1,720 | 1,720 | 1,720 | 241.65 | 415,635 |
| WDK | Wood Deck | 0 | 434 | 0 | 0.00 | 0 |
| Ttl Gross Liv / Lease Area | | 3,064 | 4,582 | 3,064 | | 740,410 |

