

CURRENT OWNER		TOPO		UTILITIES		STRT / ROAD		LOCATION		CURRENT ASSESSMENT			
HANEY, WILLIAM M III 61 LINCOLN ROAD WAYLAND MA 01778		1	Level	2	Public Water	1	Paved			Description	Code	Assessed	Assessed
				4	Gas					RESIDENTL	1010	584,100	584,100
				6	Septic					RES LAND	1010	1,489,500	1,489,500
SUPPLEMENTAL DATA													
Alt Prcl ID Split Zonin BID Parcel ResExpt Q #DL 1 LOT 3 #DL 2 GIS ID F_946841_2685180					Plan Ref. Land Ct# 9216-D #SR Life Estate PP STATU Assoc Pid#					Total 2,073,600 2,073,600			

801
FY2024
BARNSTABLE, MA

VISION

RECORD OF OWNERSHIP		BK-VOL/PAGE		SALE DATE		Q/U	V/I	SALE PRIC	VC	PREVIOUS ASSESSMENTS (HISTORY)					
HANEY, WILLIAM M III	C196912	0	04-26-2012	U	I	1	1			Year	Code	Assessed	Year	Code	Assessed
HANEY, WILLIAM & GILSON, ANNE	C137151	0	05-12-1995	Q	I	382,500	U			2023	1010	495,700	2022	1010	402,100
CHAIKOVSKY, MARIANNA TR	C115983	0	11-10-1988	U	I	1	A				1010	1,172,600		1010	878,900
BEREZNICKI, IVAN & CHAIKOVSKY, MAR	C112613	0	10-30-1987	Q	I	345,000	U							1010	2,500
GRIFFIN, JAMES JR K	C84362	0	01-21-1981	U		0				Total 1,668,300		Total 1,281,000		Total 1,267,800	

EXEMPTIONS			OTHER ASSESSMENTS					
Year	Code	Description	Amount	Code	Description	Number	Amount	Comm Int
Total			0.00					

This signature acknowledges a visit by a Data Collector or Assessor

ASSESSING NEIGHBORHOOD				
Nbhd	Nbhd Name	B	Tracing	Batch
0117				COTUIT

APPRaised VALUE SUMMARY		
Appraised Bldg. Value (Card)		546,100
Appraised Xf (B) Value (Bldg)		35,500
Appraised Ob (B) Value (Bldg)		2,500
Appraised Land Value (Bldg)		1,489,500
Special Land Value		0
Total Appraised Parcel Value		2,073,600
Valuation Method		C
Total Appraised Parcel Value		2,073,600

BUILDING PERMIT RECORD								VISIT / CHANGE HISTORY						
Permit Id	Issue Date	Type	Description	Amount	Insp Date	% Comp	Date Comp	Comments	Date	Id	Type	Is	Cd	Purpost/Result
201401963	04-11-2014	IN	Insulation	6,700	06-30-2014	100	06-30-2014	IN / WEATHERIZATION, WOO	05-17-2022	CK	02		03	Cycl Insp Comp
34195	10-21-1998	AD	Addition	225,000	06-01-1999	100	06-30-2000		06-09-2020	WD			FR	Field Review
B33631	03-01-1990	AD	Addition	100,000	01-15-1992	100	06-30-1992	CO ADD'N	07-01-2013	RB	03		02	Bldg Permit Completed
B32428	11-01-1988	WD	Wood Deck	16,000	01-15-1989	100	06-30-1989	CO DECK	06-02-2005	PT	02		01	Meas/Est
									04-19-2000	PT	01		00	Meas/Listed-Interior Acces
									04-13-2000	PT	02		01	Meas/Est
									06-01-1999	AM	02		02	Bldg Permit Completed

LAND LINE VALUATION SECTION																	
B	Use Code	Description	Zone	LA	Land Units	Unit Price	Size Adj	AC Disc	Site Index	Cond.	Nbhd.	Nbhd. Adj	Notes	Location Adjustmen	Adj Unit P	Land Value	
1	1010	Single Fam M-0	RF	2	0.390	AC 176,344.00	2.23277	1.0000	5	1.00	0117	9.700			1.0000	3,819,258	1,489,500
Total Card Land Units					0.39	AC	Parcel Total Land Area					0.39	Total Land Value				1,489,500

CONSTRUCTION DETAIL			CONSTRUCTION DETAIL (CONTINUED)		
Element	Cd	Description	Element	Cd	Description
Style	03	Colonial			
Model	01	Residential			
Grade:	C+	Average Plus			
Stories	2	2 Stories			
Exterior Wall 1	14	Wood Shingle			
Exterior Wall 2					
RooF Structure	03	Gable/Hip			
RooF Cover	03	Asph/F Gls/Cmp			
Interior Wall 1	05	Drywall			
Interior Wall 2					
Interior Floor 1	12	Hardwood			
Interior Floor 2					
Heat Fuel	03	Gas			
Heat Type	04	Hot Air			
AC Type	03	Central			
Bedrooms	06	6 Bedrooms			
Full Baths	3				
Half Baths	1				
Extra Fixtures					
Total Rooms	10	10 Rooms			
Bath Style					
Kitchen Style					
Occupancy					
UsrflD 105					
Accessory Apt					
Foundation Alt	04	Brick Walls			
Rms Prts					
Bath Split	31	3 Full-1 Half			

CONDO DATA				
Parcel Id		C	Owne	0.0
Adjust Type	Code	Description	Factor%	
Condo Flr				
Condo Unit				

COST / MARKET VALUATION	
Building Value New	791,423
Year Built	1880
Effective Year Built	1979
Depreciation Code	A
Remodel Rating	
Year Remodeled	
Depreciation %	31
Functional Obsol	0
External Obsol	0
Trend Factor	1
Condition	
Condition %	
Percent Good	69
RCNLD	546,100
Dep % Ovr	
Dep Ovr Comment	
Misc Imp Ovr	
Misc Imp Ovr Comment	
Cost to Cure Ovr	
Cost to Cure Ovr Comment	

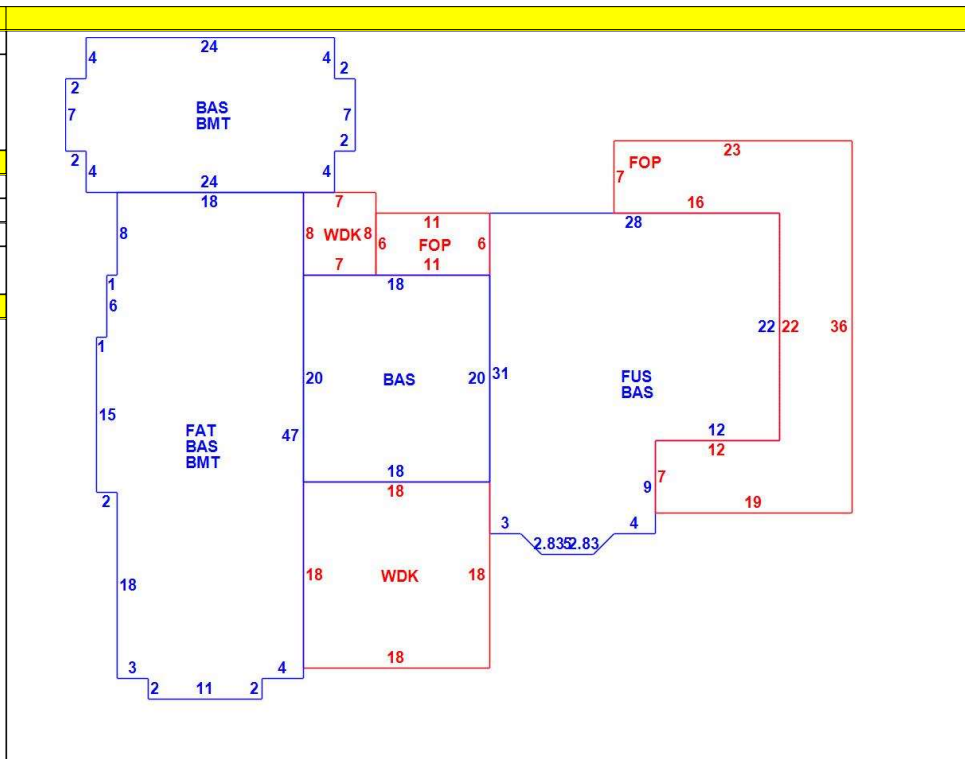

OB - OUTBUILDING & YARD ITEMS(L) / XF - BUILDING EXTRA FEATURES(B)										
Code	Description	L/B	Units	Unit Price	Yr Blt	Cond. Cd	% Gd	Grade	Grade Adj.	Appr. Value
WDC	Wood Decking	L	380	20.00	1986		34		0.00	2,500
FOP	Open Porch-ro	B	514	55.00	1979		69		0.00	13,600
BMT	Basement-Unfi	B	1,292	26.01	1979		69		0.00	21,900

BUILDING SUB-AREA SUMMARY SECTION						
Code	Description	Living Area	Floor Area	Eff Area	Unit Cost	Undeprec Value
BAS	First Floor	2,426	2,426	2,426	237.24	575,537
BMT	Basement Area	0	1,292	0	0.00	0
FAT	Attic, Finished	136	904	136	35.69	32,264
FOP	Open Porch	0	514	0	0.00	0
FUS	Upper Story	774	774	774	237.24	183,621
WDK	Wood Deck	0	380	0	0.00	0
Ttl Gross Liv / Lease Area		3,336	6,290	3,336		791,422

