

| CURRENT OWNER | | TOPO | UTILITIES | STRT / ROAD | LOCATION | CURRENT ASSESSMENT | | | | |
|--|--|------|-----------|--|----------|--------------------|------|-----------|-----------|---------------------------------|
| KENNEDY, EDWARD M JR & SHRIVE EDWARD M KENNEDY JR TRUST FO C/O PARK AGENCY INC 330 MADISON AVENUE SUITE 2303 NEW YORK NY 10017 | | | | | | Description | Code | Assessed | Assessed | 801 FY2024 BARNSTABLE, MA |
| | | | | | | RESIDENTL | 1010 | 1,693,800 | 1,693,800 | |
| | | | | | | RES LAND | 1010 | 2,078,800 | 2,078,800 | VISION |
| SUPPLEMENTAL DATA | | | | | | Total | | | | |
| Alt Prcl ID Split Zonin BID Parcel ResExpt Q #DL 1 PARCEL B #DL 2 GIS ID F_983318_2692740 | | | | Plan Ref. 622/63 Land Ct# #SR Life Estate PP STATU Assoc Pid# | | | | 3,772,600 | 3,772,600 | |

| RECORD OF OWNERSHIP | | BK-VOL/PAGE | SALE DATE | Q/U | V/I | SALE PRIC | VC | PREVIOUS ASSESSMENTS (HISTORY) | | | | | | | | | |
|-----------------------------------|--|-------------|------------|-----|-----|-----------|----|--------------------------------|------|-----------|------|-----------|------------|-------|------|-----------|--|
| KENNEDY, EDWARD M JR & SHRIVER, T | | 34491 037 | 09-21-2021 | U | I | 10 | 1F | Year | Code | Assessed | Year | Code | Assessed V | Year | Code | Assessed | |
| KENNEDY, EDWARD M JR | | 34419 104 | 08-27-2021 | U | I | 10 | 1F | 2023 | 1010 | 1,433,400 | 2022 | 1010 | 1,179,000 | 2021 | 1010 | 948,700 | |
| FORD, MICHAEL D TR | | 24817 0303 | 09-10-2010 | U | I | 0 | 1 | | 1010 | 2,677,300 | | 1010 | 1,370,700 | | 1010 | 1,370,700 | |
| FORD, MICHAEL D TR | | 22909 0314 | 05-15-2008 | U | I | 1 | 1F | | | | | | | | 1010 | 23,100 | |
| FORD, MICHAEL D TR | | 18686 0228 | 06-07-2004 | U | I | 3,000,000 | 1A | | | | | | | | | | |
| Total | | | | | | | | 4,110,700 | | Total | | 2,549,700 | | Total | | 2,342,500 | |

| EXEMPTIONS | | | OTHER ASSESSMENTS | | | | | |
|------------|------|-------------|-------------------|------|-------------|--------|--------|----------|
| Year | Code | Description | Amount | Code | Description | Number | Amount | Comm Int |
| Total | | | 0.00 | | | | | |

| ASSESSING NEIGHBORHOOD | | | |
|------------------------|-----------|---|---------------|
| Nbhd | Nbhd Name | B | Tracing |
| 0119 | | | Batch HYAN |

| NOTES | | | |
|---|--|--|-----------|
| This signature acknowledges a visit by a Data Collector or Assessor | | | |
| APPRAISED VALUE SUMMARY | | | |
| Appraised Bldg. Value (Card) | | | 1,609,500 |
| Appraised Xf (B) Value (Bldg) | | | 61,200 |
| Appraised Ob (B) Value (Bldg) | | | 23,100 |
| Appraised Land Value (Bldg) | | | 2,078,800 |
| Special Land Value | | | 0 |
| Total Appraised Parcel Value | | | 3,772,600 |
| Valuation Method | | | C |
| Total Appraised Parcel Value | | | 3,772,600 |

| BUILDING PERMIT RECORD | | | | | | | | | VISIT / CHANGE HISTORY | | | | | |
|------------------------|------------|------|----------------|---------|------------|--------|------------|-------------------------|------------------------|----|------|----|----|-----------------------|
| Permit Id | Issue Date | Type | Description | Amount | Insp Date | % Comp | Date Comp | Comments | Date | Id | Type | Is | Cd | Purpost/Result |
| 201202739 | 06-11-2012 | RA | Remodel-Additi | 500,000 | 07-03-2013 | 100 | 06-30-2013 | ADD 18X19 OBSERVATION R | 05-27-2020 | WD | | | FR | Field Review |
| 201105090 | 09-21-2011 | NW | New Windows | 40,000 | 06-30-2012 | 100 | 06-30-2012 | RESIDE-3 NW DRS-38 NW W | 10-23-2017 | SR | 02 | | 03 | Cycl Insp Comp |
| 201101239 | 03-17-2011 | RE | Remodel | 30,000 | 07-03-2013 | 100 | 06-30-2013 | KIT,BTH,LAUNDRY REMOD- | 11-04-2015 | AL | 03 | | 16 | In Office Review |
| 200801814 | 04-07-2008 | DE | Demolish | 14,000 | 07-17-2008 | 100 | 06-30-2008 | DEMO ACCESSORY | 07-24-2013 | RB | 03 | | 02 | Bldg Permit Completed |
| | | | | | | | | | 04-07-2011 | RB | 03 | | 16 | In Office Review |
| | | | | | | | | | 04-23-2010 | JR | 03 | | 16 | In Office Review |
| | | | | | | | | | 07-17-2008 | JG | 03 | | 16 | In Office Review |

| LAND LINE VALUATION SECTION | | | | | | | | | | | | | | | | |
|-----------------------------|----------|----------------|------|----|------------|------------|------------------------|---------|------------|-------|-------|-----------|------------------|--------------------|------------|------------|
| B | Use Code | Description | Zone | LA | Land Units | Unit Price | Size Adj | AC Disc | Site Index | Cond. | Nbhd. | Nbhd. Adj | Notes | Location Adjustmen | Adj Unit P | Land Value |
| 1 | 1010 | Single Fam M-0 | RF-1 | 4 | 0.810 AC | 176,344.00 | 1.21279 | 1.0000 | 5 | 1.00 | 0119 | 12.000 | | 1.0000 | 2,566,422 | 2,078,800 |
| Total Card Land Units | | | | | 0.81 | AC | Parcel Total Land Area | | | | | 0.81 | Total Land Value | | | 2,078,800 |

| CONSTRUCTION DETAIL | | | CONSTRUCTION DETAIL (CONTINUED) | | |
|---------------------|------|----------------|---------------------------------|----|-------------|
| Element | Cd | Description | Element | Cd | Description |
| Style | 06 | Conventional | | | |
| Model | 01 | Residential | | | |
| Grade: | A | Luxury | | | |
| Stories | 1.75 | 1 3/4 Stories | | | |
| Exterior Wall 1 | 14 | Wood Shingle | | | |
| Exterior Wall 2 | | | | | |
| RooF Structure | 03 | Gable/Hip | | | |
| RooF Cover | 03 | Asph/F Gls/Cmp | | | |
| Interior Wall 1 | 03 | Plastered | | | |
| Interior Wall 2 | | | | | |
| Interior Floor 1 | 12 | Hardwood | | | |
| Interior Floor 2 | | | | | |
| Heat Fuel | 03 | Gas | | | |
| Heat Type | 04 | Hot Air | | | |
| AC Type | 03 | Central | | | |
| Bedrooms | 09 | 9 Bedrooms | | | |
| Full Baths | 6 | | | | |
| Half Baths | 1 | | | | |
| Extra Fixtures | | | | | |
| Total Rooms | 13 | | | | |
| Bath Style | | | | | |
| Kitchen Style | | | | | |
| Occupancy | | | | | |
| Usrflid 105 | | | | | |
| Accessory Apt | | | | | |
| Foundation Alt | 04 | Brick Walls | | | |
| Rms Prts | | | | | |
| Bath Split | 61 | 6 Full-1 Half | | | |

| CONDO DATA | | | | |
|-------------|------|-------------|---------|----------|
| Parcel Id | | C | | Owne 0.0 |
| Adjust Type | Code | Description | Factor% | |
| Condo Flr | | | | |
| Condo Unit | | | | |

| COST / MARKET VALUATION | | |
|--------------------------|--|-----------|
| Building Value New | | 1,916,022 |
| Year Built | | 1925 |
| Effective Year Built | | 1999 |
| Depreciation Code | | E |
| Remodel Rating | | |
| Year Remodeled | | |
| Depreciation % | | 16 |
| Functional Obsol | | 0 |
| External Obsol | | 0 |
| Trend Factor | | 1 |
| Condition | | |
| Condition % | | |
| Percent Good | | 84 |
| RCNLD | | 1,609,500 |
| Dep % Ovr | | |
| Dep Ovr Comment | | |
| Misc Imp Ovr | | |
| Misc Imp Ovr Comment | | |
| Cost to Cure Ovr | | |
| Cost to Cure Ovr Comment | | |

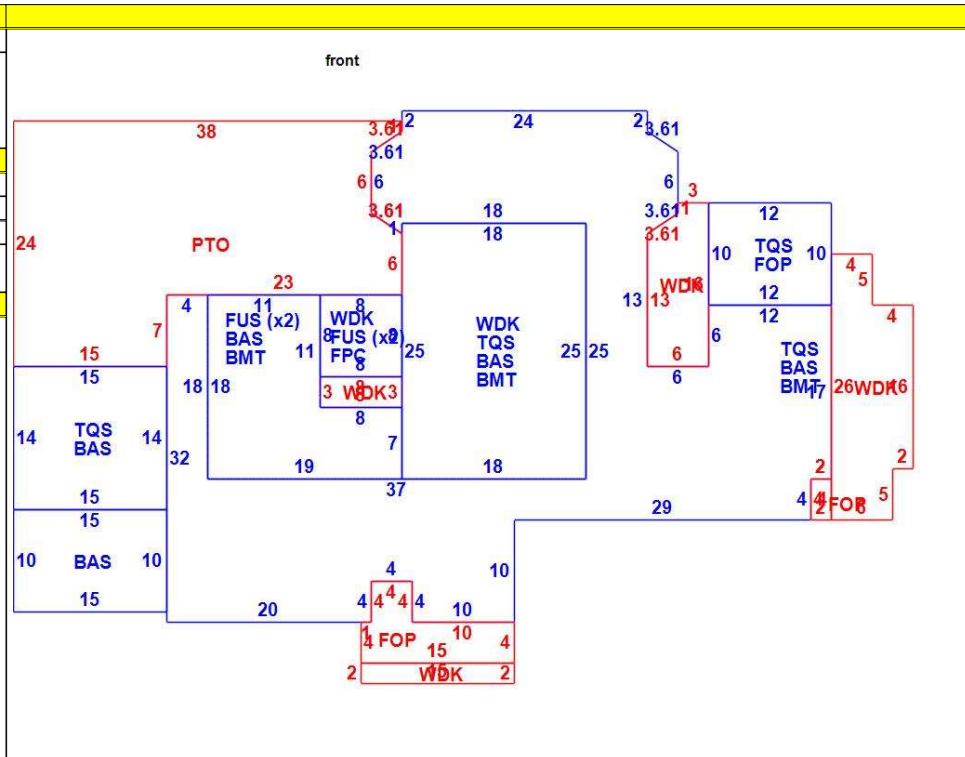

| OB - OUTBUILDING & YARD ITEMS(L) / XF - BUILDING EXTRA FEATURES(B) | | | | | | | | | | |
|--|-----------------|-----|-------|------------|--------|----------|------|-------|------------|-------------|
| Code | Description | L/B | Units | Unit Price | Yr Blt | Cond. Cd | % Gd | Grade | Grade Adj. | Appr. Value |
| FPL3 | Fireplace 2 sto | B | 2 | 7000.00 | 1999 | | 84 | | 0.00 | 11,800 |
| WDC | Wood Decking | L | 538 | 20.00 | 2012 | | 86 | | 0.00 | 8,600 |
| PAT1 | Patio- Average | L | 727 | 5.89 | 1996 | | 77 | | 0.00 | 3,100 |
| FOP | Open Porch-ro | B | 204 | 55.00 | 1999 | | 84 | | 0.00 | 7,600 |
| BMT | Basement-Unfi | B | 2,084 | 26.01 | 1999 | | 84 | | 0.00 | 38,900 |
| FOPC | Open Prch-roo | B | 64 | 55.00 | 1999 | | 84 | | 0.00 | 2,900 |
| WDC | Wood Deck w/ | L | 298 | 18.00 | 2012 | | 86 | | 0.00 | 4,600 |
| SHD3 | Shed-High Qu | L | 144 | 25.00 | 1997 | | 56 | | 0.00 | 2,000 |
| FOPG | Open Prch-rf-c | L | 70 | 49.37 | 1997 | | 78 | A | 1.58 | 4,800 |

| BUILDING SUB-AREA SUMMARY SECTION | | | | | | |
|-----------------------------------|------------------------|-------------|------------|----------|-----------|----------------|
| Code | Description | Living Area | Floor Area | Eff Area | Unit Cost | Undeprec Value |
| BAS | First Floor | 2,444 | 2,444 | 2,444 | 427.30 | 1,044,326 |
| BMT | Basement Area | 0 | 2,084 | 0 | 0.00 | 0 |
| FOP | Open Porch | 0 | 204 | 0 | 0.00 | 0 |
| FPC | Open Porch Conc. Floor | 0 | 64 | 0 | 0.00 | 0 |
| FUS | Upper Story | 636 | 636 | 636 | 427.30 | 271,764 |
| PTO | Patio | 0 | 727 | 0 | 0.00 | 0 |
| TQS | Three Quarter Story | 1,404 | 2,160 | 1,404 | 277.75 | 599,932 |
| WDK | Wood Deck | 0 | 836 | 0 | 0.00 | 0 |
| Ttl Gross Liv / Lease Area | | 4,484 | 9,155 | 4,484 | | 1,916,022 |

