

CURRENT OWNER		TOPO	UTILITIES	STRT / ROAD	LOCATION	CURRENT ASSESSMENT				801 FY2024 BARNSTABLE, MA VISION							
ROONEY, DOUGLAS M JR & POTTEB 356 SCUDDER AVE HYANNIS MA 02601		1 Level	2 Public Water	1 Paved		Description	Code	Assessed	Assessed			RESIDNTL 1010 349,300 RES LAND 1010 161,900					
			4 Gas														
			6 Septic														
SUPPLEMENTAL DATA						Total		511,200	511,200								
Alt Prcl ID		Split Zonin		Plan Ref. 525/20													
BID Parcel				Land Ct#													
ResExpt Q YES:				#SR													
#DL 1 LOT 2				Life Estate													
#DL 2				PP STATU													
GIS ID F_983320_2695885				Assoc Pid#													
RECORD OF OWNERSHIP		BK-VOL/PAGE	SALE DATE	Q/U	V/I	SALE PRIC	VC	PREVIOUS ASSESSMENTS (HISTORY)									
ROONEY, DOUGLAS M JR & POTTEBAU		29653 0196	05-16-2016	Q	I	274,500	00	Year	Code	Assessed	Year	Code	Assessed				
BEARISTO, ROBERT W		20850 0280	03-24-2006	Q	I	296,500	00	2023	1010	295,900	2022	1010	250,700				
FBP REALTY LLC		13905 0082	06-05-2001	U	I	100	1		1010	160,000		1010	113,700				
PAPPAS, FRED A B		8033 0004	05-22-1992	U	I	95,000	1					1010	7,200				
RHODES, FRANK B		7771 0326	11-26-1991	U	I	100,000	1L										
								Total		455,900	Total		364,400				
								Total			Total		311,000				
EXEMPTIONS			OTHER ASSESSMENTS					This signature acknowledges a visit by a Data Collector or Assessor									
Year	Code	Description	Amount	Code	Description	Number	Amount	Comm Int									
2023	5C	RESIDENTIAL EXEMPTION	0.00														
Total			0.00														
ASSESSING NEIGHBORHOOD																	
Nbhd	Nbhd Name		B		Tracing			Batch									
0106								HYAN									
NOTES																	
BUILDING PERMIT RECORD								VISIT / CHANGE HISTORY									
Permit Id	Issue Date	Type	Description	Amount	Insp Date	% Comp	Date Comp	Comments	Date	Id	Type	Is	Cd	Purpost/Result			
B35172	06-01-1992	AD	Addition	5,000	01-15-1993	100		HY REMOD'	12-20-2022	JO			16	In Office Review			
B35171	06-01-1992	AD	Addition	20,000	01-15-1993	100		HY REMOD'	08-11-2021	BM	22		22	Change of Address			
									05-26-2020	WD			FR	Field Review			
									06-10-2016	JR	03		20	Sale Review			
									04-05-2016	NF	03		16	In Office Review			
									01-23-2015	SR	02		14	Cyclical Inspection			
									02-08-2002	PT	01		00	Meas/Listed-Interior Acces			
LAND LINE VALUATION SECTION																	
B	Use Code	Description	Zone	LA	Land Units	Unit Price	Size Adj	AC Disc	Site Index	Cond.	Nbhd.	Nbhd. Adj	Notes	Location Adjustmen	Adj Unit P	Land Value	
1	1010	Single Fam M-0	RB	4	0.180 AC	176,344.00	4.43465	1.0000	5	1.00	0106	1.150		1.0000	899,336.7	161,900	
Total Card Land Units					0.18 AC	Parcel Total Land Area					0.18	Total Land Value					161,900

CONSTRUCTION DETAIL			CONSTRUCTION DETAIL (CONTINUED)		
Element	Cd	Description	Element	Cd	Description
Style	01	Ranch			
Model	01	Residential			
Grade:	C+	Average Plus			
Stories	1	1 Story			
Exterior Wall 1	14	Wood Shingle			
Exterior Wall 2	11	Clapboard			
Roof Structure	03	Gable/Hip			
Roof Cover	03	Asph/F Gls/Cmp			
Interior Wall 1	05	Drywall			
Interior Wall 2					
Interior Floor 1	14	Carpet			
Interior Floor 2					
Heat Fuel	03	Gas			
Heat Type	05	Hot Water			
AC Type	01	None			
Bedrooms	03	3 Bedrooms			
Full Baths	2				
Half Baths	0				
Extra Fixtures					
Total Rooms	5	5 Rooms			
Bath Style					
Kitchen Style					
Occupancy					
Usrflid 105					
Accessory Apt					
Foundation Alt	02	Conc. Block			
Rms Prts					
Bath Split	20	2 Full-0 Half			

CONDO DATA			
Parcel Id		C	Ownr 0.0
		B	S
Adjust Type	Code	Description	Factor%
Condo Flr			
Condo Unit			

COST / MARKET VALUATION	
Building Value New	377,671
Year Built	1900
Effective Year Built	2005
Depreciation Code	E
Remodel Rating	
Year Remodeled	
Depreciation %	11
Functional Obsol	0
External Obsol	0
Trend Factor	1
Condition	
Condition %	
Percent Good	89
RCNLD	336,100
Dep % Ovr	
Dep Ovr Comment	
Misc Imp Ovr	
Misc Imp Ovr Comment	
Cost to Cure Ovr	
Cost to Cure Ovr Comment	

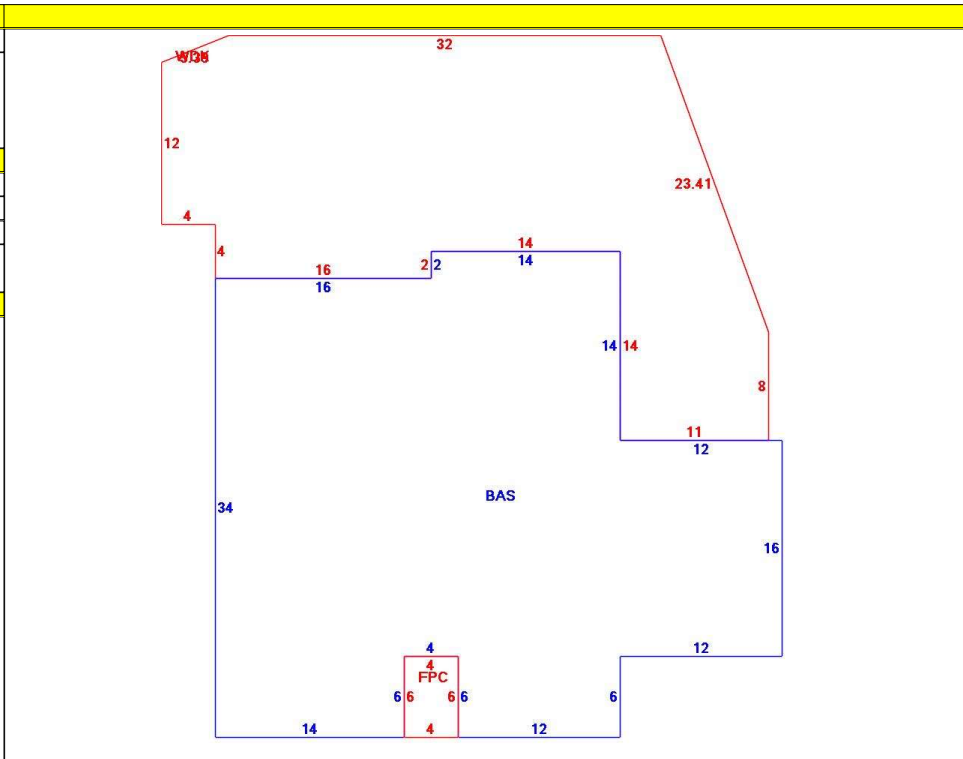

OB - OUTBUILDING & YARD ITEMS(L) / XF - BUILDING EXTRA FEATURES(B)										
Code	Description	L/B	Units	Unit Price	Yr Blt	Cond. Cd	% Gd	Grade	Grade Adj.	Appr. Value
WDC	Wood Decking	L	805	20.00	1986		34		0.00	5,000
FOPC	Open Prch-roo	B	24	55.00	2005		89		0.00	1,500
FPL1	Fireplace 1 sto	B	1	5000.00	2005		89		0.00	4,500
SHED	Shed	L	120	18.00	2019		100		0.00	2,200

BUILDING SUB-AREA SUMMARY SECTION						
Code	Description	Living Area	Floor Area	Eff Area	Unit Cost	Undeprec Value
BAS	First Floor	1,216	1,216	1,216	310.59	377,671
FPC	Open Porch Conc. Floor	0	24	0	0.00	0
WDK	Wood Deck	0	805	0	0.00	0
Ttl Gross Liv / Lease Area		1,216	2,045	1,216		377,671

