

CURRENT OWNER		TOPO	UTILITIES	STRT / ROAD	LOCATION	CURRENT ASSESSMENT				801 FY2024 BARNSTABLE, MA	
TAYLOR, JOHN R & JUDITH R TRS TAYLOR NOB HILL REALTY TRUST 33 NOB HILL RD HYANNIS PORT MA 02647		1 Level	2 Public Water	3 Unpaved		Description	Code	Assessed	Assessed		
			4 Gas			RESIDNTL	1010	544,400	544,400		
			6 Septic			RES LAND	1010	469,900	469,900		
SUPPLEMENTAL DATA						Total				1,014,300	1,014,300
Alt Prcl ID		Split Zonin		Plan Ref. 111/93							
BID Parcel		ResExpt Q		Land Ct#							
#DL 1		LOTS 42A & 44A		#SR							
#DL 2				Life Estate							
GIS ID		F_984256_2695024		PP STATU							
				Assoc Pid#							

VISION

RECORD OF OWNERSHIP		BK-VOL/PAGE	SALE DATE	Q/U	V/I	SALE PRIC	VC	PREVIOUS ASSESSMENTS (HISTORY)								
TAYLOR, JOHN R & JUDITH R TRS		13277 0344	10-03-2000	U	I	100	1F	Year	Code	Assessed	Year	Code	Assessed	Year	Code	Assessed
TAYLOR, JOHN R & JUDITH R		9511 0176	01-15-1995	Q	I	259,000	U	2023	1010	465,900	2022	1010	399,700	2021	1010	321,900
KETTLEWELL, JOHN D		8766 0118	09-15-1993	Q	I	163,500	U		1010	330,800		1010	280,700		1010	255,200
JANSEN, LESTER S & SHAPIRO, ROBER		7724 0050	10-15-1991	U	I	1	A								1010	3,500
COHEN, MORRIS		3189 0339	11-10-1980	U		0		Total		796,700	Total		680,400	Total		580,600

EXEMPTIONS			OTHER ASSESSMENTS				This signature acknowledges a visit by a Data Collector or Assessor							
Year	Code	Description	Amount	Code	Description	Number	Amount	Comm	Int					
Total			0.00											

ASSESSING NEIGHBORHOOD				APPRAISED VALUE SUMMARY					
Nbhd	Nbhd Name	B	Tracing	Batch					
0110				HYAN					

NOTES													APPRAISED VALUE SUMMARY						
													Appraised Bldg. Value (Card)						493,300
													Appraised Xf (B) Value (Bldg)						47,600
													Appraised Ob (B) Value (Bldg)						3,500
													Appraised Land Value (Bldg)						469,900
													Special Land Value						0
													Total Appraised Parcel Value						1,014,300
													Valuation Method						C
													Total Appraised Parcel Value						1,014,300

BUILDING PERMIT RECORD										VISIT / CHANGE HISTORY					
Permit Id	Issue Date	Type	Description	Amount	Insp Date	% Comp	Date Comp	Comments		Date	Id	Type	Is	Cd	Purpost/Result
										05-26-2020	WD			FR	Field Review
										10-05-2017	SR	01		03	Cycl Insp Comp
										08-09-2010	NF	03		16	In Office Review
										02-20-2002	PT	01		00	Meas/Listed-Interior Acces
										10-15-1988	ME	02		01	Meas/Est

LAND LINE VALUATION SECTION																	
B	Use Code	Description	Zone	LA	Land Units	Unit Price	Size Adj	AC Disc	Site Index	Cond.	Nbhd.	Nbhd. Adj	Notes	Location Adjustmen	Adj Unit P	Land Value	
1	1010	Single Fam M-0	RF-1	4	0.330 AC	176,344.00	2.60499	1.0000	5	1.00	0110	3.100		1.0000	1,424,065	469,900	
Total Card Land Units					0.33 AC	Parcel Total Land Area					0.33	Total Land Value					469,900

CONSTRUCTION DETAIL			CONSTRUCTION DETAIL (CONTINUED)		
Element	Cd	Description	Element	Cd	Description
Style	01	Ranch			
Model	01	Residential			
Grade:	C+	Average Plus			
Stories	1	1 Story			
Exterior Wall 1	11	Clapboard			
Exterior Wall 2					
RooF Structure	03	Gable/Hip			
RooF Cover	03	Asph/F Gls/Cmp			
Interior Wall 1	05	Drywall			
Interior Wall 2					
Interior Floor 1	14	Carpet			
Interior Floor 2					
Heat Fuel	03	Gas			
Heat Type	05	Hot Water			
AC Type	03	Central			
Bedrooms	03	3 Bedrooms			
Full Baths	2				
Half Baths	0				
Extra Fixtures					
Total Rooms	7	7 Rooms			
Bath Style					
Kitchen Style					
Occupancy					
Usrflid 105					
Accessory Apt					
Foundation Alt	01	Poured Conc.			
Rms Prts					
Bath Split	20	2 Full-0 Half			

CONDO DATA			
Parcel Id		C	Ownr 0.0
Adjust Type	Code	Description	Factor%
Condo Flr			
Condo Unit			

COST / MARKET VALUATION	
Building Value New	640,592
Year Built	1966
Effective Year Built	1989
Depreciation Code	A
Remodel Rating	
Year Remodeled	
Depreciation %	23
Functional Obsol	0
External Obsol	0
Trend Factor	1
Condition	
Condition %	
Percent Good	77
RCNLD	493,300
Dep % Ovr	
Dep Ovr Comment	
Misc Imp Ovr	
Misc Imp Ovr Comment	
Cost to Cure Ovr	
Cost to Cure Ovr Comment	

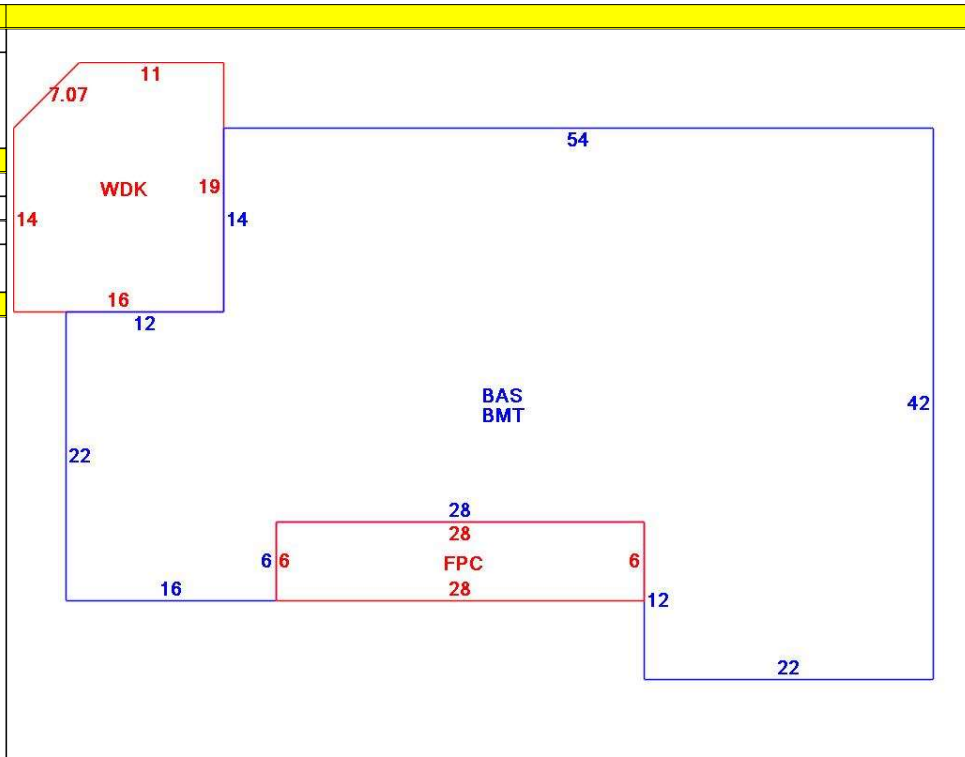

OB - OUTBUILDING & YARD ITEMS(L) / XF - BUILDING EXTRA FEATURES(B)										
Code	Description	L/B	Units	Unit Price	Yr Blt	Cond. Cd	% Gd	Grade	Grade Adj.	Appr. Value
FPL1	Fireplace 1 sto	B	1	5000.00	1991		77		0.00	3,900
BGAR	Bsmt Garage	B	1	2326.00	1991		77		0.00	1,800
FOPC	Open Prch-roo	B	168	55.00	1991		77		0.00	5,100
BMT	Basement-Unfi	B	2,172	26.01	1991		77		0.00	36,800
WDC	Wood Decking	L	292	20.00	1999		60		0.00	3,500

BUILDING SUB-AREA SUMMARY SECTION						
Code	Description	Living Area	Floor Area	Eff Area	Unit Cost	Undeprec Value
BAS	First Floor	2,172	2,172	2,172	294.93	640,592
BMT	Basement Area	0	2,172	0	0.00	0
FPC	Open Porch Conc. Floor	0	168	0	0.00	0
WDC	Wood Deck	0	292	0	0.00	0
Ttl Gross Liv / Lease Area		2,172	4,804	2,172		640,592

