

CURRENT OWNER		TOPO	UTILITIES	STRT / ROAD	LOCATION	CURRENT ASSESSMENT				801 FY2024 BARNSTABLE, MA VISION	
HAYDEN,ROBERT F JR&KNISS, ELIZ HAYDEN REAL ESTATE TRUST PO BOX 496 COTUIT MA 02635		1 Level	2 Public Water	1 Paved	1 Marginal View	Description	Code	Assessed	Assessed		
			4 Gas			RESIDNTL	1010	260,700	260,700		
			6 Septic			RES LAND	1010	877,600	877,600		
SUPPLEMENTAL DATA						Total				1,138,300	1,138,300
Alt Prcl ID		Split Zonin		Plan Ref. 300/32							
BID Parcel		ResExpt Q		Land Ct#							
#DL 1 LOT B		#DL 2		Life Estate							
GIS ID F_947025_2685794		Assoc Pid#									

RECORD OF OWNERSHIP		BK-VOL/PAGE	SALE DATE	Q/U	V/I	SALE PRIC	VC	PREVIOUS ASSESSMENTS (HISTORY)								
HAYDEN,ROBERT F JR&KNISS, ELIZABE		18644 0015	05-27-2004	U	I	1	1F	Year	Code	Assessed	Year	Code	Assessed			
HAYDEN, ROBERT F JR & KNISS, ELIZA		2448 0207	12-30-1976	U		0		2023	1010	224,600	2022	1010	247,700			
HAYDEN, ROBERT F & ELIZABETH C		1539 0172	03-25-1967	U	I	0			1010	797,800		1010	646,400			
											2021	1010	198,700			
												1010	692,600			
												1010	9,700			
								Total		1,022,400	Total		894,100	Total		901,000

EXEMPTIONS			OTHER ASSESSMENTS				This signature acknowledges a visit by a Data Collector or Assessor					
Year	Code	Description	Amount	Code	Description	Number	Amount	Comm Int				
Total			0.00									

ASSESSING NEIGHBORHOOD				APPRAISED VALUE SUMMARY				
Nbhd	Nbhd Name	B	Tracing	Batch				
0115				COTUIT				
NOTES				Appraised Bldg. Value (Card)				227,000
				Appraised Xf (B) Value (Bldg)				24,400
				Appraised Ob (B) Value (Bldg)				9,300
				Appraised Land Value (Bldg)				877,600
				Special Land Value				0
				Total Appraised Parcel Value				1,138,300
				Valuation Method				C
				Total Appraised Parcel Value				1,138,300

BUILDING PERMIT RECORD									VISIT / CHANGE HISTORY					
Permit Id	Issue Date	Type	Description	Amount	Insp Date	% Comp	Date Comp	Comments	Date	Id	Type	Is	Cd	Purpost/Result
B17808	07-01-1975	AD	Addition	0	01-15-1977	100	12-31-1977	CO ADD'N	08-18-2022	SR	02		03	Cycl Insp Comp
									06-09-2020	WD			FR	Field Review
									02-04-2020	CK	02		03	Cycl Insp Comp
									07-01-2013	RB	03		02	Bldg Permit Completed
									03-25-2010	JR	03		15	Abatement Review
									12-23-2008	JR	03		16	In Office Review
									05-08-2007	KLP	03		16	In Office Review

LAND LINE VALUATION SECTION																
B	Use Code	Description	Zone	LA	Land Units	Unit Price	Size Adj	AC Disc	Site Index	Cond.	Nbhd.	Nbhd. Adj	Notes	Location Adjustmen	Adj Unit P	Land Value
1	1010	Single Fam M-0	RF	2	0.150 AC	176,344.00	5.18399	1.0000	5	1.00	0115	6.400		1.0000	5,850,670	877,600
Total Card Land Units					0.15	AC	Parcel Total Land Area					0.15	Total Land Value			877,600

CONSTRUCTION DETAIL			CONSTRUCTION DETAIL (CONTINUED)		
Element	Cd	Description	Element	Cd	Description
Style	01	Ranch			
Model	01	Residential			
Grade:	C	Average			
Stories	1	1 Story			
Exterior Wall 1	16	Stucco on Wood			
Exterior Wall 2	14	Wood Shingle			
Roof Structure	03	Gable/Hip			
Roof Cover	03	Asph/F Gls/Cmp			
Interior Wall 1	05	Drywall			
Interior Wall 2					
Interior Floor 1	12	Hardwood			
Interior Floor 2					
Heat Fuel	03	Gas			
Heat Type	04	Hot Air			
AC Type	03	Central			
Bedrooms	02	2 Bedrooms			
Full Baths	2				
Half Baths	0				
Extra Fixtures					
Total Rooms	5	5 Rooms			
Bath Style					
Kitchen Style					
Occupancy					
Usrflid 105					
Accessory Apt					
Foundation Alt	02	Conc. Block			
Rms Prts					
Bath Split	20	2 Full-0 Half			

CONDO DATA			
Parcel Id		C	Owne 0.0
Adjust Type	Code	Description	Factor%
Condo Flr			
Condo Unit			

COST / MARKET VALUATION	
Building Value New	329,046
Year Built	1930
Effective Year Built	1979
Depreciation Code	A
Remodel Rating	
Year Remodeled	
Depreciation %	31
Functional Obsol	0
External Obsol	0
Trend Factor	1
Condition	
Condition %	
Percent Good	69
RCNLD	227,000
Dep % Ovr	
Dep Ovr Comment	
Misc Imp Ovr	
Misc Imp Ovr Comment	
Cost to Cure Ovr	
Cost to Cure Ovr Comment	

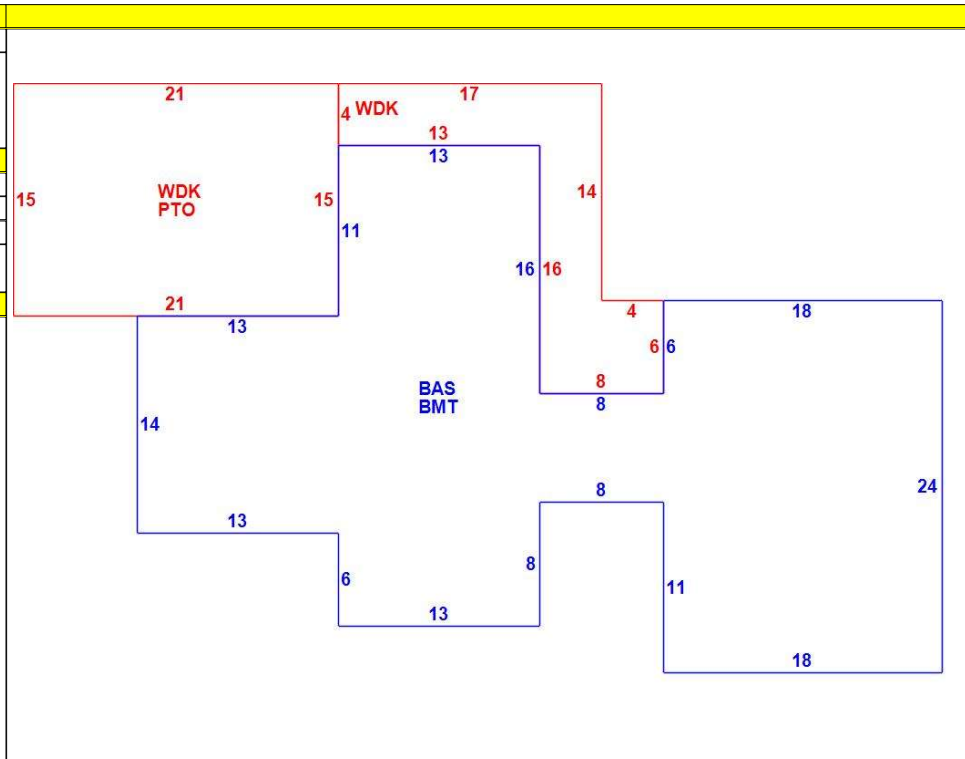

OB - OUTBUILDING & YARD ITEMS(L) / XF - BUILDING EXTRA FEATURES(B)										
Code	Description	L/B	Units	Unit Price	Yr Blt	Cond. Cd	% Gd	Grade	Grade Adj.	Appr. Value
FPL1	Fireplace 1 sto	B	1	5000.00	1979		69		0.00	3,500
BFA	Bsmt Fin-Avg	B	144	17.36	1979		69		0.00	1,700
WDC	Wood Decking	L	471	20.00	1986		34		0.00	3,000
PATF	Flagstone Pav	L	315	30.00	1986		67		0.00	6,300
BMT	Basement-Unfi	B	1,073	26.01	1979		69		0.00	19,200

BUILDING SUB-AREA SUMMARY SECTION						
Code	Description	Living Area	Floor Area	Eff Area	Unit Cost	Undeprec Value
BAS	First Floor	1,073	1,073	1,073	306.66	329,046
BMT	Basement Area	0	1,073	0	0.00	0
PTO	Patio	0	315	0	0.00	0
WDK	Wood Deck	0	471	0	0.00	0
Ttl Gross Liv / Lease Area		1,073	2,932	1,073		329,046

