

CURRENT OWNER		TOPO	UTILITIES	STRT / ROAD	LOCATION	CURRENT ASSESSMENT					
BARIGHT, RICHARD S & CARLEEN S RICHARD S BARIGHT LIVING TRUST PO BOX 483  TIVOLI NY 12583						Description	Code	Assessed	Assessed	801  FY2024 BARNSTABLE, MA  <h1>VISION</h1>	
						RESIDNTL	1020	479,400	479,400		
SUPPLEMENTAL DATA						Total					
Alt Prcl ID		Split Zonin RB;RF-1		Plan Ref. Land Ct# 20984-B-1							
#DL 1 UNIT 1		#DL 2		Life Estate PP STATU VIE PARCEL TO							
GIS ID F_985112_2695172		Assoc Pid#									

RECORD OF OWNERSHIP		BK-VOL/PAGE	SALE DATE	Q/U	V/I	SALE PRICE	VC	PREVIOUS ASSESSMENTS (HISTORY)								
BARIGHT, RICHARD S & CARLEEN S TRS	C97-1	0	07-09-2014	U	I	10	1A	Year	Code	Assessed	Year	Code	Assessed	Year	Code	Assessed
BARIGHT, RICHARD S & CARLEEN S	C97-0	0	08-30-2007	Q	I	410,000	00	2023	1020	467,400	2022	1020	404,400	2021	1020	351,300
FULLER, TIMOTHY	C97-0	0	10-02-2000	Q	I	159,900	00								1020	8,300
CURRIER, LAURELIE	C97-0	0	10-30-1996	U	I	1	1A									
CURRIER, DONALD G & LAURELIE W	C97-0	0	01-15-1996	U	I	107,500	1									
Total								467,400		Total		404,400		Total		359,600

EXEMPTIONS			OTHER ASSESSMENTS					
Year	Code	Description	Amount	Code	Description	Number	Amount	Comm Int
Total			0.00					

ASSESSING NEIGHBORHOOD				
Nbhd	Nbhd Name	B	Tracing	Batch
0001				HYAN

  

APPRAISED VALUE SUMMARY	
Appraised Bldg. Value (Card)	465,200
Appraised Xf (B) Value (Bldg)	3,900
Appraised Ob (B) Value (Bldg)	10,300
Appraised Land Value (Bldg)	0
Special Land Value	0
Total Appraised Parcel Value	479,400
Valuation Method	C
Total Appraised Parcel Value	479,400

BUILDING PERMIT RECORD										VISIT / CHANGE HISTORY					
Permit Id	Issue Date	Type	Description	Amount	Insp Date	% Comp	Date Comp	Comments		Date	Id	Type	Is	Cd	Purpost/Result
200707214	11-26-2007	RE	Remodel	10,300		100		INTERIOR		05-25-2023	TR	03		16	In Office Review
B35825	04-01-1993	WD	Wood Deck	1,700	01-15-1994	100		HP DECK		05-26-2020	WD			FR	Field Review
										03-21-2019	SR	02		03	Cycl Insp Comp
										08-25-2008	JG	03		16	In Office Review

LAND LINE VALUATION SECTION																		
B	Use Code	Description	Zone	Dist	Land Type	Land Units	Unit Price	Size Adj	Site Index	Cond.	Nbhd.	Nbhd. Adj	Notes	Location Adjustmen	Adj Unit P	Land Value		
1	102U	Condominium M	SPLI	4		0 SF	0.00	1.00000	5	1.00	0001	1.000		0.0000	0	0		
Total Card Land Units						0 SF	Parcel Total Land Area						0.00	Total Land Value				0

CONSTRUCTION DETAIL			CONSTRUCTION DETAIL (CONTINUED)		
Element	Cd	Description	Element	Cd	Description
Style	55	Condominium			
Model	05	Res Condo			
Bedrm Func	C	Average			
Stories	1	1 Story			
Occupancy	0				
Interior Wall 1	05	Drywall			
Interior Wall 2					
Interior Floor 1	11	Ceram Clay Til			
Interior Floor 2	12	Hardwood			
Heat Fuel	03	Gas			
Heat Type	04	Hot Air			
AC Type	03	Central			
Bedrooms	01	1 Bedroom			
Full Baths	1	1 Full			
Half Baths	0				
Extra Fixtures					
Total Rooms	2	2 Rooms			
Bath Style					
Kitchen Style					
Master Deed L	581				
Bath Split	10	1 Full-0 Half			
Foundation	02	Conc. Block			
AC Type Alt					
Sewer Occupan					
<b>CONDO DATA</b>					
Parcel Id	104271	C 0570	Ownr	4.7	
	HARBOR VILLAGE	B 1	S 1		
Adjust Type	Code	Description	Factor%		
Condo Flr			100		
Condo Unit	MKT0	MKT0	100		
<b>COST / MARKET VALUATION</b>					
Building Value New		604,161			
Year Built		1952			
Effective Year Built		1990			
Depreciation Code		A			
Remodel Rating					
Year Remodeled		23			
Depreciation %		0			
Functional Obsol		0			
External Obsol		0			
Trend Factor		1			
Condition					
Condition %		77			
Percent Good		465,200			
Cns Sect Rcnld					
Dep % Ovr					
Dep Ovr Comment					
Misc Imp Ovr					
Misc Imp Ovr Comment					
Cost to Cure Ovr					
Cost to Cure Ovr Comment					

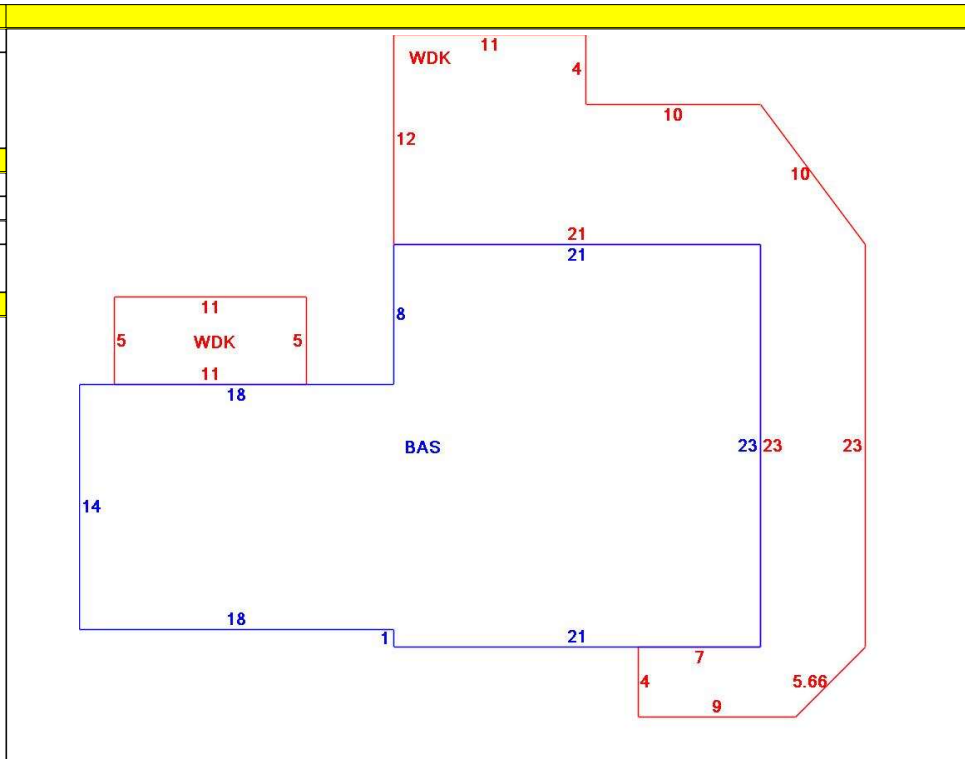

OB - OUTBUILDING & YARD ITEMS(L) / XF - BUILDING EXTRA FEATURES(B)										
Code	Description	L/B	Units	Unit Price	Yr Blt	Cond. Cd	% Gd	Grade	Grade Adj.	Appr. Value
FPL1	Fireplace 1 sto	B	1	5000.00	1991		77		0.00	3,900
WDC	Deck comp w	L	418	28.00	2000		62		0.00	7,000
WDC	Deck composit	L	55	24.00	2000		62		0.00	2,200
SHED	Shed	L	100	18.00	2000		62		0.00	1,100

BUILDING SUB-AREA SUMMARY SECTION							
Code	Description	Living Area	Floor Area	Eff Area	Unit Cost	Undeprec Value	
BAS	First Floor	735	735	735	821.99	604,161	
WDK	Wood Deck	0	473	0	0.00	0	
Ttl Gross Liv / Lease Area		735	1,208	735		604,161	

