

CURRENT OWNER		TOPO	UTILITIES	STRT / ROAD	LOCATION	CURRENT ASSESSMENT												
MILNE, LOUISA B & JOHN K TRS CASSIOPEIA REALTY TRUST 71 WOODFORD STREET PORTLAND ME 04103						Description	Code	Assessed	Assessed									
						RESIDNTL	1020	505,900	505,900									
SUPPLEMENTAL DATA																		
Alt Prcl ID			Plan Ref.															
Split Zonin RB;RF-1			Land Ct# 20984-B-1															
BID Parcel			#SR															
ResExpt Q			Life Estate															
#DL 1 UNIT 12			PP STATU															
#DL 2																		
GIS ID F_985112_2695172			Assoc Pid#															
						Total		505,900	505,900									
RECORD OF OWNERSHIP		BK-VOL/PAGE	SALE DATE	Q/U	V/I	SALE PRICE	VC	PREVIOUS ASSESSMENTS (HISTORY)										
MILNE, LOUISA B & JOHN K TRS		C97-1 0	09-30-2016	U	I	100	1F	Year	Code	Assessed	Year	Code	Assessed V	Year	Code	Assessed		
MILNE, JOHN K & LOUISA B		C97-1 0	07-15-1994	Q	I	85,000	U	2023	1020	500,600	2022	1020	432,700	2021	1020	381,300		
BENGEN, BARBARA S		C97-1 0	04-15-1987	Q	I	155,000	U								1020	3,100		
TOSCANO, ELIZABETH M		C97 0	05-07-1981	Q	I	85,000	U											
						Total		500,600	Total		432,700	Total		384,400				
EXEMPTIONS			OTHER ASSESSMENTS				This signature acknowledges a visit by a Data Collector or Assessor											
Year	Code	Description	Amount	Code	Description	Number											Amount	Comm Int
Total			0.00															
ASSESSING NEIGHBORHOOD						APPRAISED VALUE SUMMARY Appraised Bldg. Value (Card) 494,800 Appraised Xf (B) Value (Bldg) 7,000 Appraised Ob (B) Value (Bldg) 4,100 Appraised Land Value (Bldg) 0 Special Land Value 0 Total Appraised Parcel Value 505,900 Valuation Method C Total Appraised Parcel Value 505,900												
Nbhd	Nbhd Name		B		Tracing											Batch		
0001							HYAN											
NOTES																		
BUILDING PERMIT RECORD								VISIT / CHANGE HISTORY										
Permit Id	Issue Date	Type	Description	Amount	Insp Date	% Comp	Date Comp	Comments	Date	Id	Type	Is	Cd	Purpost/Result				
BLDR-21-12 B33051	09-24-2021 07-01-1989	880 AD	Alt-Int work-Res Addition	2,738 12,500	01-15-1991	100 100		Insulation and Weatherization HP ADD'N	05-25-2023 05-26-2020 08-12-2019 03-21-2019 03-23-2015 01-24-2013	TR WD CK SR TP TP	03 22 02 03 03		16 FR 22 03 16 16	In Office Review Field Review Change of Address Cycl Insp Comp In Office Review In Office Review				
LAND LINE VALUATION SECTION																		
B	Use Code	Description	Zone	Dist	Land Type	Land Units	Unit Price	Size Adj	Site Index	Cond.	Nbhd.	Nbhd. Adj	Notes	Location Adjustmen	Adj Unit P	Land Value		
1	102U	Condominium M	SPLI	4		0 SF	0.00	1.00000	5	1.00	0001	1.000		0.0000	0	0		
Total Card Land Units						0 SF	Parcel Total Land Area						0.00	Total Land Value				0

801
 FY2024
 BARNSTABLE, MA
VISION

CONSTRUCTION DETAIL			CONSTRUCTION DETAIL (CONTINUED)		
Element	Cd	Description	Element	Cd	Description
Style	55	Condominium			
Model	05	Res Condo			
Bedrm Func	C	Average			
Stories	1	1 Story			
Occupancy	0				
Interior Wall 1	04	Plywood Panel			
Interior Wall 2	05	Drywall			
Interior Floor 1	14	Carpet			
Interior Floor 2	09	Pine/Soft Wood			
Heat Fuel	03	Gas			
Heat Type	04	Hot Air			
AC Type	03	Central			
Bedrooms	02	2 Bedrooms			
Full Baths	1	1 Full			
Half Baths	1				
Extra Fixtures					
Total Rooms	4	4 Rooms			
Bath Style					
Kitchen Style					
Master Deed L	794				
Bath Split	11	1 Full-1 Half			
Foundation	02	Conc. Block			
AC Type Alt					
Sewer Occupan					
CONDO DATA					
Parcel Id	104271	C 0570	Owne	4.7	
	HARBOR VILLAGE	B 1	S 1		
Adjust Type	Code	Description	Factor%		
Condo Flr			100		
Condo Unit	MKT0	MKT0	100		
COST / MARKET VALUATION					
Building Value New		634,340			
Year Built		1957			
Effective Year Built		1991			
Depreciation Code		A			
Remodel Rating					
Year Remodeled					
Depreciation %		22			
Functional Obsol		0			
External Obsol		0			
Trend Factor		1			
Condition					
Condition %					
Percent Good		78			
Cns Sect Rcnld		494,800			
Dep % Ovr					
Dep Ovr Comment					
Misc Imp Ovr					
Misc Imp Ovr Comment					
Cost to Cure Ovr					
Cost to Cure Ovr Comment					

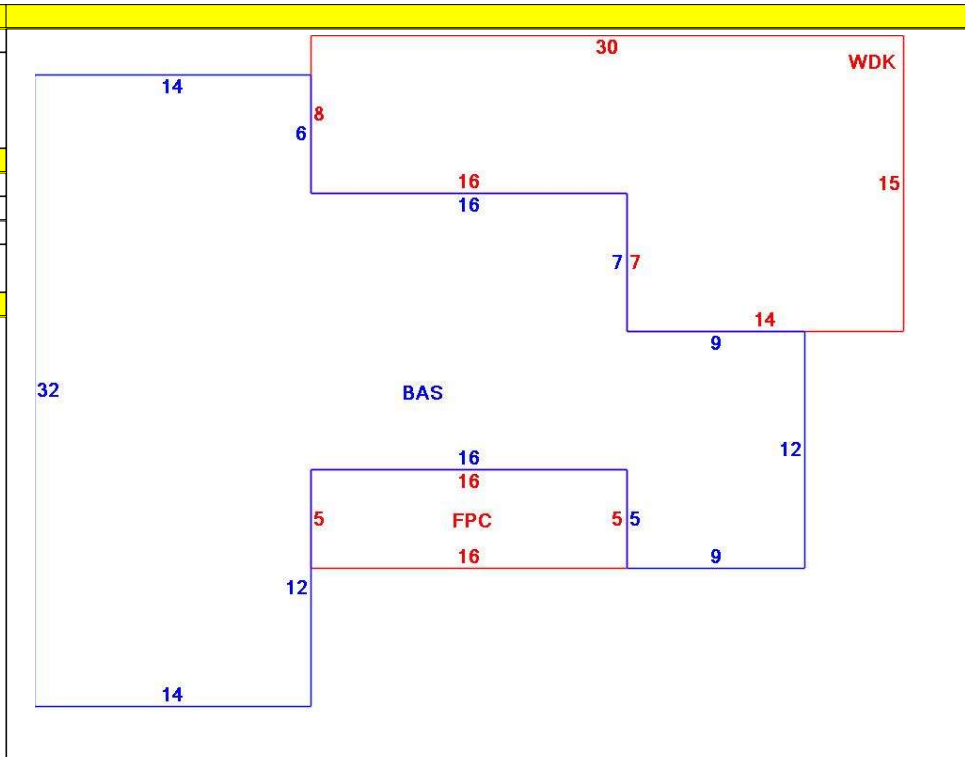

OB - OUTBUILDING & YARD ITEMS(L) / XF - BUILDING EXTRA FEATURES(B)										
Code	Description	L/B	Units	Unit Price	Yr Blt	Cond. Cd	% Gd	Grade	Grade Adj.	Appr. Value
FPL1	Fireplace 1 sto	B	1	5000.00	1993		78		0.00	3,900
WDC	Wood Decking	L	338	20.00	2000		62		0.00	4,100
FOPC	Open Prch-roo	B	80	55.00	1993		78		0.00	3,100

BUILDING SUB-AREA SUMMARY SECTION						
Code	Description	Living Area	Floor Area	Eff Area	Unit Cost	Undeprec Value
BAS	First Floor	780	780	780	813.26	634,340
FPC	Open Porch Conc. Floor	0	80	0	0.00	0
WDK	Wood Deck	0	338	0	0.00	0
Ttl Gross Liv / Lease Area		780	1,198	780		634,340

