

CURRENT OWNER		TOPO	UTILITIES	STRT / ROAD	LOCATION	CURRENT ASSESSMENT			
URREJOLA, CARMEN GLORIA & GAR  65 BRIARWOOD AVENUE  HYANNIS MA 02601		1 Level	2 Public Water	1 Paved		Description	Code	Assessed	Assessed
			4 Gas			RESIDNTL	1010	263,500	263,500
			6 Septic			RES LAND	1010	172,800	172,800
<b>SUPPLEMENTAL DATA</b>						Total 436,300 436,300			
Alt Prcl ID Split Zonin BID Parcel ResExpt Q #DL 1 LOT 19 #DL 2 GIS ID F_983732_2696966				Plan Ref. 38/91 Land Ct# #SR Life Estate PP STATU Assoc Pid#					

801  
 FY2024  
 BARNSTABLE, MA  
**VISION**

RECORD OF OWNERSHIP		BK-VOL/PAGE	SALE DATE	Q/U	V/I	SALE PRIC	VC	PREVIOUS ASSESSMENTS (HISTORY)					
URREJOLA, CARMEN GLORIA & GARCE		29065 0316	08-10-2015	Q	I	245,000	00	Year	Code	Assessed	Year	Code	Assessed
FINNERAN, MELISSA & SEAN TRS		26984 0058	12-27-2012	U	I	0	1A	2023	1010	223,000	2022	1010	188,800
FINNERAN, MELISSA TR		26984 0057	12-27-2012	U	I	0	1F		1010	170,800		1010	121,400
MICHAUD, EDWARD&DORIS & FINNERA		21158 0019	07-05-2006	U	I	1	1A					1010	4,600
FINNERAN, SEAN & MELISSA		20898 0086	04-07-2006	U	I	1	1A	Total		393,800	Total		310,200
								Total			Total		271,400

EXEMPTIONS			OTHER ASSESSMENTS					
Year	Code	Description	Amount	Code	Description	Number	Amount	Comm Int
Total			0.00					

This signature acknowledges a visit by a Data Collector or Assessor

ASSESSING NEIGHBORHOOD			
Nbhd	Nbhd Name	B	Tracing
0106			Batch HYAN

NOTES			

APPRAISED VALUE SUMMARY	
Appraised Bldg. Value (Card)	254,800
Appraised Xf (B) Value (Bldg)	4,100
Appraised Ob (B) Value (Bldg)	4,600
Appraised Land Value (Bldg)	172,800
Special Land Value	0
Total Appraised Parcel Value	436,300
Valuation Method	C
Total Appraised Parcel Value	436,300

BUILDING PERMIT RECORD								VISIT / CHANGE HISTORY						
Permit Id	Issue Date	Type	Description	Amount	Insp Date	% Comp	Date Comp	Comments	Date	Id	Type	Is	Cd	Purpost/Result
19-3518	10-18-2019	835	Sid/Wind/Roof/	3,500		100		REROOF	05-26-2020	WD			FR	Field Review
19-3194	09-27-2019	835	Sid/Wind/Roof/	3,500		100		Re- shingle	01-26-2018	SR	01		03	Cycl Insp Comp
16812	07-25-1996	AD	Addition	3,100	08-12-1997	100	01-01-1997		06-10-2016	JR	03		20	Sale Review
									10-18-2004	PT	02		01	Meas/Est
									02-12-2002	PT	01		00	Meas/Listed-Interior Acces
									08-12-1997	LK	02		01	Meas/Est
									06-15-1988	ME	02		01	Meas/Est

LAND LINE VALUATION SECTION																	
B	Use Code	Description	Zone	LA	Land Units	Unit Price	Size Adj	AC Disc	Site Index	Cond.	Nbhd.	Nbhd. Adj	Notes	Location Adjustmen	Adj Unit P	Land Value	
1	1010	Single Fam M-0	RB	4	0.290 AC	176,344.00	2.93869	1.0000	5	1.00	0106	1.150		1.0000	595,954.5	172,800	
Total Card Land Units					0.29 AC	Parcel Total Land Area					0.29	Total Land Value					172,800

CONSTRUCTION DETAIL			CONSTRUCTION DETAIL (CONTINUED)		
Element	Cd	Description	Element	Cd	Description
Style	01	Ranch			
Model	01	Residential			
Grade:	C	Average			
Stories	1	1 Story			
Exterior Wall 1	14	Wood Shingle			
Exterior Wall 2					
Roof Structure	03	Gable/Hip			
Roof Cover	03	Asph/F Gls/Cmp			
Interior Wall 1	05	Drywall			
Interior Wall 2					
Interior Floor 1	12	Hardwood			
Interior Floor 2					
Heat Fuel	03	Gas			
Heat Type	04	Hot Air			
AC Type	03	Central			
Bedrooms	02	2 Bedrooms			
Full Baths	1				
Half Baths	0				
Extra Fixtures					
Total Rooms	4	4 Rooms			
Bath Style					
Kitchen Style					
Occupancy					
Usrflid 105					
Accessory Apt					
Foundation Alt	02	Conc. Block			
Rms Prts					
Bath Split	10	1 Full-0 Half			
			<b>CONDO DATA</b>		
			Parcel Id	C	Owne 0.0
				B	S
			Adjust Type	Code	Description
			Condo Flr		Factor%
			Condo Unit		
			<b>COST / MARKET VALUATION</b>		
			Building Value New		314,625
			Year Built		1956
			Effective Year Built		1994
			Depreciation Code		VG
			Remodel Rating		
			Year Remodeled		
			Depreciation %		19
			Functional Obsol		0
			External Obsol		0
			Trend Factor		1
			Condition		
			Condition %		
			Percent Good		81
			RCNLD		254,800
			Dep % Ovr		
			Dep Ovr Comment		
			Misc Imp Ovr		
			Misc Imp Ovr Comment		
			Cost to Cure Ovr		
			Cost to Cure Ovr Comment		

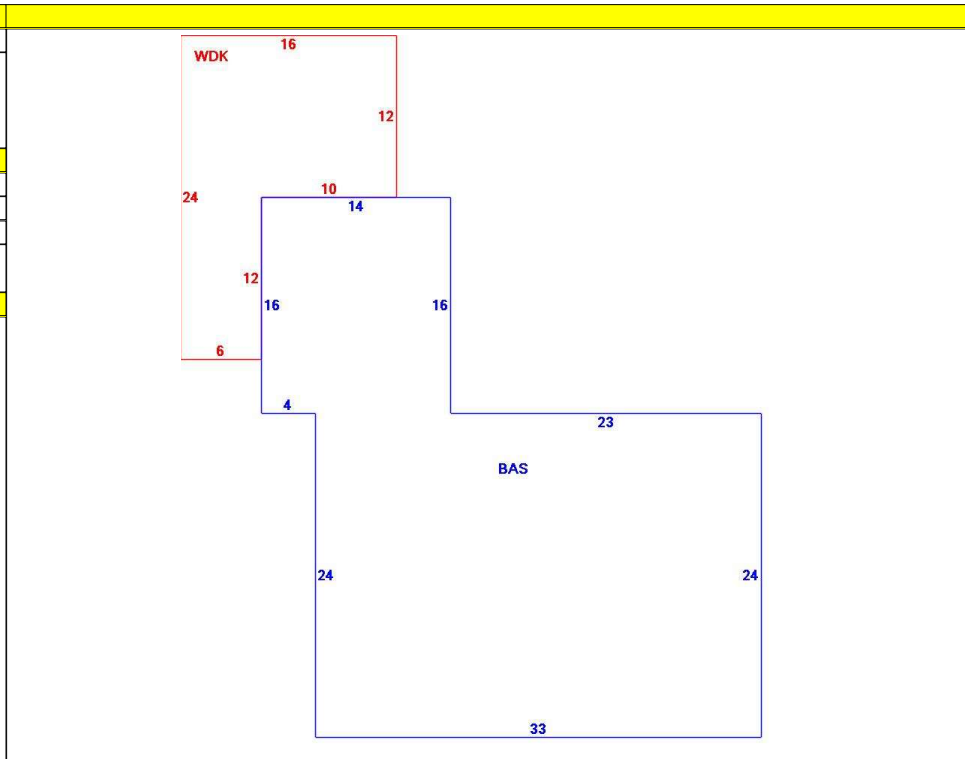

OB - OUTBUILDING & YARD ITEMS(L) / XF - BUILDING EXTRA FEATURES(B)										
Code	Description	L/B	Units	Unit Price	Yr Blt	Cond. Cd	% Gd	Grade	Grade Adj.	Appr. Value
FPL1	Fireplace 1 sto	B	1	5000.00	1996		81		0.00	4,100
WDC	Wood Decking	L	264	20.00	1992		46		0.00	2,600
SHED	Shed	L	120	18.00	1993		48		0.00	1,000
SHED	Shed	L	120	18.00	1993		48		0.00	1,000

BUILDING SUB-AREA SUMMARY SECTION						
Code	Description	Living Area	Floor Area	Eff Area	Unit Cost	Undeprec Value
BAS	First Floor	1,016	1,016	1,016	309.67	314,625
WDC	Wood Deck	0	264	0	0.00	0
Ttl Gross Liv / Lease Area		1,016	1,280	1,016		314,625

