

CURRENT OWNER		TOPO	UTILITIES	STRT / ROAD	LOCATION	CURRENT ASSESSMENT				801 FY2024 BARNSTABLE, MA VISION							
WHITCOMB, LINDA						Description	Code	Assessed	Assessed								
88 GREENWOOD AVENUE		SUPPLEMENTAL DATA				RESIDNTL	1010	467,500	467,500								
HYANNIS MA 02601		Alt Prcl ID Split Zonin BID Parcel ResExpt Q #DL 1 LOT 10 #DL 2 GIS ID F_984311_2697183				RES LAND	1010	168,700	168,700								
						Total		636,200	636,200								
RECORD OF OWNERSHIP		BK-VOL/PAGE	SALE DATE	Q/U	V/I	SALE PRIC	VC	PREVIOUS ASSESSMENTS (HISTORY)									
WHITCOMB, LINDA		33242 0148	09-09-2020	U	I	1	1F	Year	Code	Assessed	Year	Code	Assessed				
WHITCOMB, CHARLES A JR & LINDA		31423 0305	07-25-2018	U	I	1	1F	2023	1010	403,200	2022	1010	348,800				
WHITCOMB, LINDA MARIE CARA DONN		16588 0020	03-17-2003	U	I	0	1F		1010	166,700		1010	118,500				
MARKARIAN, LINDA M		12368 0310	06-28-1999	U	I	1	1A					1010	6,200				
MARKARIAN, CHARLES J ET AL		5784 0222	06-15-1987	U	I	1	A	Total		569,900	Total		467,300				
		Total						Total		406,200	Total		406,200				
EXEMPTIONS			OTHER ASSESSMENTS				This signature acknowledges a visit by a Data Collector or Assessor										
Year	Code	Description	Amount	Code	Description	Number	Amount	Comm Int									
Total		0.00															
ASSESSING NEIGHBORHOOD																	
Nbhd		Nbhd Name		B		Tracing		Batch									
0106								HYAN									
NOTES																	
BUILDING PERMIT RECORD																	
Permit Id	Issue Date	Type	Description	Amount	Insp Date	% Comp	Date Comp	Comments	Date	Id	Type	Is	Cd	Purpost/Result			
B26681	07-01-1984	DW	Dwelling	23,152	01-15-1986	100	12-31-1986	HY	05-26-2020	WD			FR	Field Review			
									10-05-2017	SR	02		03	Cycl Insp Comp			
									07-19-2002	PT	02		01	Meas/Est			
									06-15-1988	ML	01		00	Meas/Listed-Interior Acces			
LAND LINE VALUATION SECTION																	
B	Use Code	Description	Zone	LA	Land Units	Unit Price	Size Adj	AC Disc	Site Index	Cond.	Nbhd.	Nbhd. Adj	Notes	Location Adjustmen	Adj Unit P	Land Value	
1	1010	Single Fam M-0	RB	4	0.230 AC	176,344.00	3.61599	1.0000	5	1.00	0106	1.150		1.0000	733,308.8	168,700	
Total Card Land Units					0.23 AC	Parcel Total Land Area					0.23	Total Land Value					168,700

CONSTRUCTION DETAIL			CONSTRUCTION DETAIL (CONTINUED)		
Element	Cd	Description	Element	Cd	Description
Style	01	Ranch			
Model	01	Residential			
Grade:	C	Average			
Stories	1	1 Story			
Exterior Wall 1	14	Wood Shingle			
Exterior Wall 2	11	Clapboard			
RooF Structure	03	Gable/Hip			
RooF Cover	03	Asph/F Gls/Cmp			
Interior Wall 1	03	Plastered			
Interior Wall 2					
Interior Floor 1	12	Hardwood			
Interior Floor 2					
Heat Fuel	02	Oil			
Heat Type	05	Hot Water			
AC Type	01	None			
Bedrooms	03	3 Bedrooms			
Full Baths	2				
Half Baths	1				
Extra Fixtures					
Total Rooms	6	6 Rooms			
Bath Style					
Kitchen Style					
Occupancy					
Usrflid 105					
Accessory Apt					
Foundation Alt	01	Poured Conc.			
Rms Prts					
Bath Split	21	2 Full-1 Half			

CONDO DATA			
Parcel Id	C	Owne	0.0
Adjust Type	Code	Description	Factor%
Condo Flr			
Condo Unit			

COST / MARKET VALUATION	
Building Value New	481,958
Year Built	1984
Effective Year Built	1998
Depreciation Code	A
Remodel Rating	
Year Remodeled	
Depreciation %	16
Functional Obsol	0
External Obsol	0
Trend Factor	1
Condition	
Condition %	
Percent Good	84
RCNLD	404,800
Dep % Ovr	
Dep Ovr Comment	
Misc Imp Ovr	
Misc Imp Ovr Comment	
Cost to Cure Ovr	
Cost to Cure Ovr Comment	

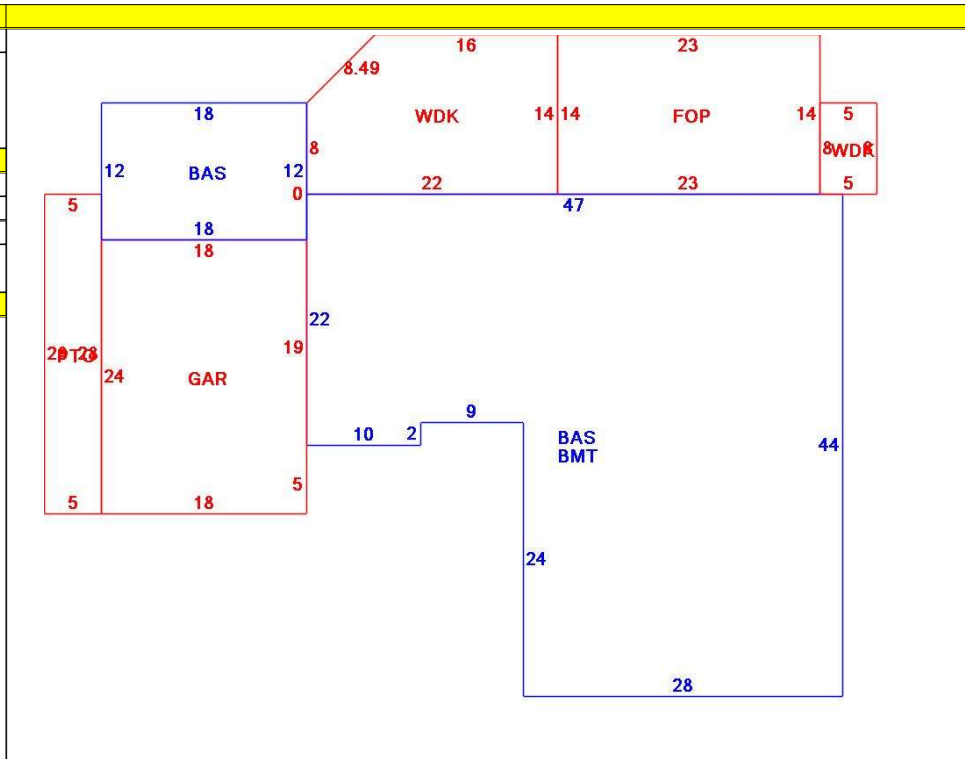

OB - OUTBUILDING & YARD ITEMS(L) / XF - BUILDING EXTRA FEATURES(B)										
Code	Description	L/B	Units	Unit Price	Yr Blt	Cond. Cd	% Gd	Grade	Grade Adj.	Appr. Value
WDC	Wood Deck w/	L	290	18.00	1999		60		0.00	3,200
FOP	Open Porch-ro	B	322	55.00	2000		84		0.00	10,600
GAR	Attached Gara	B	432	40.00	2000		84		0.00	14,200
BMT	Basement-Unfi	B	1,632	26.01	2000		84		0.00	31,700
WDC	Wood Deck w/	L	24	18.00	1999		60		0.00	1,000
PAT1	Patio- Average	L	140	5.89	1992		46		0.00	400
SHED	Shed	L	120	18.00	2007		76		0.00	1,600

BUILDING SUB-AREA SUMMARY SECTION						
Code	Description	Living Area	Floor Area	Eff Area	Unit Cost	Undeprec Value
BAS	First Floor	1,848	1,848	1,848	260.80	481,958
BMT	Basement Area	0	1,632	0	0.00	0
FOP	Open Porch	0	322	0	0.00	0
GAR	Attached Garage	0	432	0	0.00	0
PTO	Patio	0	140	0	0.00	0
WDK	Wood Deck	0	330	0	0.00	0
Ttl Gross Liv / Lease Area		1,848	4,704	1,848		481,958

