

CURRENT OWNER		TOPO		UTILITIES		STRT / ROAD		LOCATION		CURRENT ASSESSMENT				801 FY2024 BARNSTABLE, MA  <b>VISION</b>					
LOUD, YVONNE M  353 MITCHELL'S WAY  HYANNIS MA 02601		1	Level	6	Septic	1	Paved			Description	Code	Assessed	Assessed			RESIDNTL RES LAND	1010 1010	197,800 131,000	197,800 131,000
				4	Gas														
				2	Public Water														
<b>SUPPLEMENTAL DATA</b>										Total				328,800	328,800				
Alt Prcl ID		Split Zonin		Plan Ref. 76/25		Land Ct#													
BID Parcel		ResExpt Q		#SR		Life Estate		PP STATU											
#DL 1 LOT 25		#DL 2		Assoc Pid#															
GIS ID F_982874_2700909																			
RECORD OF OWNERSHIP				BK-VOL/PAGE		SALE DATE		Q/U V/I		SALE PRIC		VC		PREVIOUS ASSESSMENTS (HISTORY)					
LOUD, YVONNE M				33109	0057	07-28-2020	Q	I	269,000	00	Year	Code	Assessed	Year	Code	Assessed	Year	Code	Assessed
FERGUSON, JAY M & HEATHER A				30525	0318	05-31-2017	Q	I	227,000	00	2023	1010	167,200	2022	1010	141,400	2021	1010	105,300
RODRIGUEZ, OMAR J & JENN R E				24736	0017	08-06-2010	Q	I	197,500	00		1010	125,700		1010	93,100		1010	88,200
RICHARD, JEREMY & HEIDI P				17756	0256	10-06-2003	Q	I	165,000	00								1010	5,500
JACKSON, JAMES				7717	0006	10-18-1991	U	I	30,000	1A									
				Total						292,900		Total		234,500		Total		199,000	
EXEMPTIONS				OTHER ASSESSMENTS				This signature acknowledges a visit by a Data Collector or Assessor											
Year	Code	Description		Amount		Code	Description	Number	Amount	Comm Int									
				Total		0.00													
ASSESSING NEIGHBORHOOD												APPRAISED VALUE SUMMARY							
Nbhd		Nbhd Name		B		Tracing		Batch		Appraised Bldg. Value (Card)				192,300					
0104								HYAN		Appraised Xf (B) Value (Bldg)				0					
												Appraised Ob (B) Value (Bldg)				5,500			
												Appraised Land Value (Bldg)				131,000			
												Special Land Value				0			
												Total Appraised Parcel Value				328,800			
												Valuation Method				C			
												Total Appraised Parcel Value				328,800			
BUILDING PERMIT RECORD												VISIT / CHANGE HISTORY							
Permit Id	Issue Date	Type	Description	Amount	Insp Date	% Comp	Date Comp	Comments				Date	Id	Type	Is	Cd	Purpost/Result		
18-132	01-19-2018	822	Insulation	2,444		100		Air Sealing & Weatherization				05-01-2020	WD			FR	Field Review		
												04-25-2018	MS	03		16	In Office Review		
												04-22-2015	JR	03		03	Cycl Insp Comp		
												04-01-2015	SR	02		14	Cyclical Inspection		
												05-15-2012	JR	03		20	Sale Review		
												03-27-2008	PT	02		14	Cyclical Inspection		
												02-24-2004	PT	02		01	Meas/Est		
LAND LINE VALUATION SECTION																			
B	Use Code	Description	Zone	LA	Land Units	Unit Price	Size Adj	AC Disc	Site Index	Cond.	Nbhd.	Nbhd. Adj	Notes		Location Adjustmen		Adj Unit P	Land Value	
1	1010	Single Fam M-0	RB	4	0.220	AC	176,344.00	3.75053	1.0000	5	1.00	0104	0.900			1.0000	595,249.1	131,000	
Total Card Land Units					0.22	AC	Parcel Total Land Area					0.22	Total Land Value					131,000	

CONSTRUCTION DETAIL			CONSTRUCTION DETAIL (CONTINUED)		
Element	Cd	Description	Element	Cd	Description
Style	01	Ranch			
Model	01	Residential			
Grade:	C	Average			
Stories	1	1 Story			
Exterior Wall 1	14	Wood Shingle			
Exterior Wall 2					
Roof Structure	03	Gable/Hip			
Roof Cover	03	Asph/F Gls/Cmp			
Interior Wall 1	05	Drywall			
Interior Wall 2					
Interior Floor 1	12	Hardwood			
Interior Floor 2					
Heat Fuel	02	Oil			
Heat Type	05	Hot Water			
AC Type	03	Central			
Bedrooms	02	2 Bedrooms			
Full Baths	1				
Half Baths	0				
Extra Fixtures					
Total Rooms	4	4 Rooms			
Bath Style					
Kitchen Style					
Occupancy					
Usrflid 105					
Accessory Apt					
Foundation Alt	09	Blk/Pour Ftgs			
Rms Prts					
Bath Split	10	1 Full-0 Half			

CONDO DATA				
Parcel Id		C	Owne	0.0
Adjust Type	Code	Description	Factor%	
Condo Flr				
Condo Unit				

COST / MARKET VALUATION	
Building Value New	263,446
Year Built	1940
Effective Year Built	1984
Depreciation Code	G
Remodel Rating	
Year Remodeled	
Depreciation %	27
Functional Obsol	0
External Obsol	0
Trend Factor	1
Condition	
Condition %	
Percent Good	73
RCNLD	192,300
Dep % Ovr	
Dep Ovr Comment	
Misc Imp Ovr	
Misc Imp Ovr Comment	
Cost to Cure Ovr	
Cost to Cure Ovr Comment	

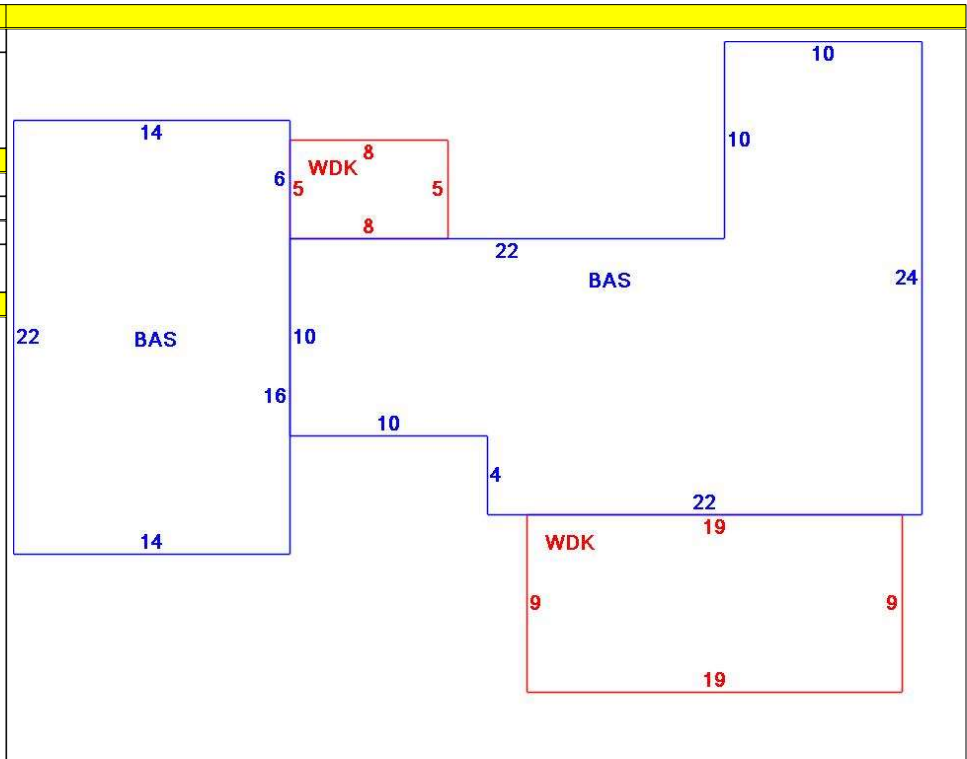

**OB - OUTBUILDING & YARD ITEMS(L) / XF - BUILDING EXTRA FEATURES(B)**

Code	Description	L/B	Units	Unit Price	Yr Blt	Cond. Cd	% Gd	Grade	Grade Adj.	Appr. Value
WDC	Wood Deck w/	L	217	18.00	2015		92		0.00	4,100
SHED	Shed	L	80	18.00	2019		100		0.00	1,400

**BUILDING SUB-AREA SUMMARY SECTION**

Code	Description	Living Area	Floor Area	Eff Area	Unit Cost	Undeprec Value
BAS	First Floor	816	816	816	322.85	263,446
WDK	Wood Deck	0	211	0	0.00	0
Ttl Gross Liv / Lease Area		816	1,027	816		263,446

