

CURRENT OWNER		TOPO	UTILITIES	STRT / ROAD	LOCATION	CURRENT ASSESSMENT			
LIMA, LEANDRO 220 COMPASS CIRCLE HYANNIS MA 02601		1 Level	6 Septic	1 Paved		Description	Code	Assessed	Assessed
			4 Gas			RESIDNTL	1010	467,200	467,200
			2 Public Water			RES LAND	1010	135,000	135,000
SUPPLEMENTAL DATA						Total			
		Alt Prcl ID Split Zonin BID Parcel ResExpt Q #DL 1 LOT 11 #DL 2 BLOCK 8 GIS ID F_983805_2701154			Plan Ref. Land Ct# 14034-H (SH 2) #SR Life Estate PP STATU Assoc Pid#		602,200		602,200

801
 FY2024
 BARNSTABLE, MA

VISION

RECORD OF OWNERSHIP		BK-VOL/PAGE	SALE DATE	Q/U	V/I	SALE PRIC	VC	PREVIOUS ASSESSMENTS (HISTORY)								
LIMA, LEANDRO	C209540	0	05-16-2016	Q	I	295,305	00	Year	Code	Assessed	Year	Code	Assessed	Year	Code	Assessed
COOPER, BONNIE MARIE TR	C205350	0	01-05-2015	U	I	1	1F	2023	1010	397,200	2022	1010	327,000	2021	1010	294,700
COOPER, BONNIE M	C189200	0	08-04-2009	U	I	1	1F		1010	129,500		1010	95,900		1010	90,900
COOPER, JOHN F & BONNIE M	C125490	0	01-15-1992	U	I	1	A								1010	4,500
COOPER, JOHN F & BONNIE M	C47577	0	12-31-1969	Q		4,700	U	Total		526,700	Total		422,900	Total		390,100

EXEMPTIONS				OTHER ASSESSMENTS			
Year	Code	Description	Amount	Code	Description	Number	Amount
2018	N5C	NO RESIDENTIAL EXEMPTION	0.00				
Total			0.00				

This signature acknowledges a visit by a Data Collector or Assessor

ASSESSING NEIGHBORHOOD			
Nbhd	Nbhd Name	B	Tracing
0104			Batch HYAN

NOTES			

APPRAISED VALUE SUMMARY	
Appraised Bldg. Value (Card)	432,700
Appraised Xf (B) Value (Bldg)	30,000
Appraised Ob (B) Value (Bldg)	4,500
Appraised Land Value (Bldg)	135,000
Special Land Value	0
Total Appraised Parcel Value	602,200
Valuation Method	C
Total Appraised Parcel Value	602,200

BUILDING PERMIT RECORD						VISIT / CHANGE HISTORY								
Permit Id	Issue Date	Type	Description	Amount	Insp Date	% Comp	Date Comp	Comments	Date	Id	Type	Is	Cd	Purpost/Result
									05-01-2020	WD			FR	Field Review
									09-11-2017	SR	02		03	Cycl Insp Comp
									03-12-2001	SM	01		00	Meas/Listed-Interior Acces
									10-15-1987	ML	01		00	Meas/Listed-Interior Acces

LAND LINE VALUATION SECTION																	
B	Use Code	Description	Zone	LA	Land Units	Unit Price	Size Adj	AC Disc	Site Index	Cond.	Nbhd.	Nbhd. Adj	Notes	Location Adjustmen	Adj Unit P	Land Value	
1	1010	Single Fam M-0	RB	4	0.280 AC	176,344.00	3.03702	1.0000	5	1.00	0104	0.900		1.0000	482,001.0	135,000	
Total Card Land Units					0.28 AC	Parcel Total Land Area					0.28	Total Land Value					135,000

CONSTRUCTION DETAIL			CONSTRUCTION DETAIL (CONTINUED)		
Element	Cd	Description	Element	Cd	Description
Style	03	Colonial			
Model	01	Residential			
Grade:	C	Average			
Stories	2	2 Stories			
Exterior Wall 1	14	Wood Shingle			
Exterior Wall 2	11	Clapboard			
RooF Structure	07	Gambrel			
RooF Cover	10	Wood Shingle			
Interior Wall 1	05	Drywall			
Interior Wall 2					
Interior Floor 1	14	Carpet			
Interior Floor 2	12	Hardwood			
Heat Fuel	03	Gas			
Heat Type	05	Hot Water			
AC Type	01	None			
Bedrooms	05	5 Bedrooms			
Full Baths	2				
Half Baths	0				
Extra Fixtures					
Total Rooms	9	9 Rooms			
Bath Style					
Kitchen Style					
Occupancy					
Usrflid 105					
Accessory Apt					
Foundation Alt	01	Poured Conc.			
Rms Prts					
Bath Split	20	2 Full-0 Half			

CONDO DATA				
Parcel Id		C	Ownr	0.0
Adjust Type	Code	Description	Factor%	
Condo Flr				
Condo Unit				

COST / MARKET VALUATION	
Building Value New	527,705
Year Built	1970
Effective Year Built	1996
Depreciation Code	G
Remodel Rating	
Year Remodeled	
Depreciation %	18
Functional Obsol	0
External Obsol	0
Trend Factor	1
Condition	
Condition %	
Percent Good	82
RCNLD	432,700
Dep % Ovr	
Dep Ovr Comment	
Misc Imp Ovr	
Misc Imp Ovr Comment	
Cost to Cure Ovr	
Cost to Cure Ovr Comment	

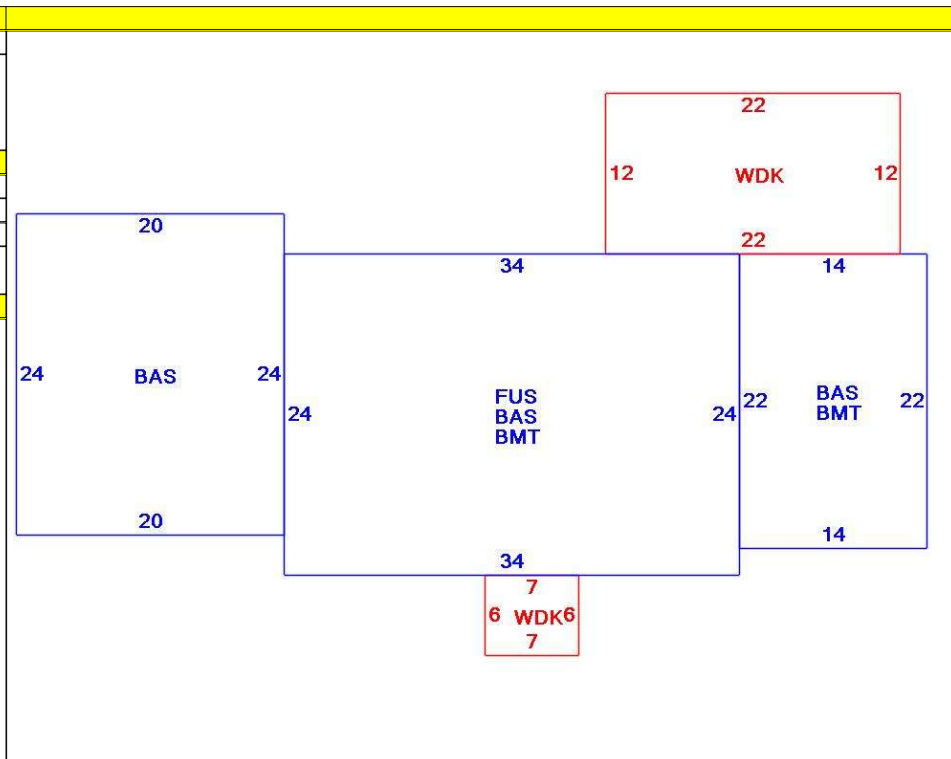

OB - OUTBUILDING & YARD ITEMS(L) / XF - BUILDING EXTRA FEATURES(B)										
Code	Description	L/B	Units	Unit Price	Yr Blt	Cond. Cd	% Gd	Grade	Grade Adj.	Appr. Value
FPL2	Fireplace 1.5 s	B	1	6000.00	1998		82		0.00	4,900
FPO	Ext FP Openin	B	1	2000.00	1998		82		0.00	1,600
WDC	Wood Decking	L	264	20.00	1995		52		0.00	2,900
BMT	Basement-Unfi	B	1,124	26.01	1998		82		0.00	23,500
WDC	Wood Decking	L	42	20.00	1999		60		0.00	1,600

BUILDING SUB-AREA SUMMARY SECTION						
Code	Description	Living Area	Floor Area	Eff Area	Unit Cost	Undeprec Value
BAS	First Floor	1,604	1,604	1,604	218.06	349,768
BMT	Basement Area	0	1,124	0	0.00	0
FUS	Upper Story	816	816	816	218.06	177,937
WDK	Wood Deck	0	306	0	0.00	0
Ttl Gross Liv / Lease Area		2,420	3,850	2,420		527,705

