

CURRENT OWNER		TOPO	UTILITIES	STRT / ROAD	LOCATION	CURRENT ASSESSMENT				801 FY2024 BARNSTABLE, MA  <b>VISION</b>	
BONTOS, LEAH  16 GEORGE STREET  HYANNIS MA 02601		1 Level	2 Public Water	1 Paved		Description	Code	Assessed	Assessed		
			4 Gas			RESIDNTL	1010	358,600	358,600		
			6 Septic			RES LAND	1010	135,000	135,000		
<b>SUPPLEMENTAL DATA</b>						Total				493,600	493,600
Alt Prcl ID Split Zonin BID Parcel ResExpt Q YES: #DL 1 LOT 2 #DL 2 BLK 3 GIS ID F_984470_2702251				Plan Ref. Land Ct# 14034-H #SR Life Estate PP STATU Assoc Pid#							

RECORD OF OWNERSHIP		BK-VOL/PAGE	SALE DATE	Q/U	V/I	SALE PRIC	VC	PREVIOUS ASSESSMENTS (HISTORY)								
BONTOS, LEAH		C172670	0	04-15-2004	Q	I	284,000	00	Year	Code	Assessed	Year	Code	Assessed		
DANIELS, E ANN		C145350	0	08-01-1997	Q	I	77,000	00	2023	1010	307,600	2022	1010	268,100		
REILLY, KATHLEEN, EXECUTRIX		#D69803	0	06-26-1997			0			1010	129,500		1010	95,900		
THOMPSON, EILEEN I		#D49431	0	11-02-1989	U	I	1	A					1010	3,400		
THOMPSON, ROBERT E & EILEEN I		C45828	0	06-17-1969	U		0		Total		437,100	Total		364,000	Total	307,400

EXEMPTIONS				OTHER ASSESSMENTS				This signature acknowledges a visit by a Data Collector or Assessor								
Year	Code	Description	Amount	Code	Description	Number	Amount	Comm Int								
2010	5C	RESIDENTIAL EXEMPTION	0.00													
Total			0.00													

ASSESSING NEIGHBORHOOD				APPRAISED VALUE SUMMARY			
Nbhd	Nbhd Name	B	Tracing	Batch			
0104				HYAN	Appraised Bldg. Value (Card)	320,300	
					Appraised Xf (B) Value (Bldg)	34,900	
					Appraised Ob (B) Value (Bldg)	3,400	
					Appraised Land Value (Bldg)	135,000	
					Special Land Value	0	
					Total Appraised Parcel Value	493,600	
					Valuation Method	C	
					Total Appraised Parcel Value	493,600	

NOTES										VISIT / CHANGE HISTORY					
										Date	Id	Type	Is	Cd	Purpost/Result
										05-01-2020	WD			FR	Field Review
										03-26-2015	SR	02		14	Cyclical Inspection
										02-10-2010	MA	22		22	Change of Address
										10-26-2004	GB			03	Cycl Insp Comp
										08-06-2004	PT	02		01	Meas/Est
										04-02-2001	MF	02		05	Measur/New UC Under C
										03-08-2001	PT	01		00	Meas/Listed-Interior Acces

BUILDING PERMIT RECORD										LAND LINE VALUATION SECTION					
Permit Id	Issue Date	Type	Description	Amount	Insp Date	% Comp	Date Comp	Comments		Date	Id	Type	Is	Cd	Purpost/Result
44498	03-03-2000	AD	Addition	21,000	04-02-2001	100	01-01-2001			05-01-2020	WD			FR	Field Review

B	Use Code	Description	Zone	LA	Land Units	Unit Price	Size Adj	AC Disc	Site Index	Cond.	Nbhd.	Nbhd. Adj	Notes	Location Adjustmen	Adj Unit P	Land Value	
1	1010	Single Fam M-0	RB	4	0.280	AC	176,344.00	3.03702	1.0000	5	1.00	0104	0.900		1.0000	482,001.0	135,000
Total Card Land Units					0.28	AC	Parcel Total Land Area					0.28	Total Land Value			135,000	

CONSTRUCTION DETAIL			CONSTRUCTION DETAIL (CONTINUED)		
Element	Cd	Description	Element	Cd	Description
Style	01	Ranch			
Model	01	Residential			
Grade:	C	Average			
Stories	1	1 Story			
Exterior Wall 1	14	Wood Shingle			
Exterior Wall 2	11	Clapboard			
RooF Structure	03	Gable/Hip			
RooF Cover	03	Asph/F Gls/Cmp			
Interior Wall 1	05	Drywall			
Interior Wall 2					
Interior Floor 1	14	Carpet			
Interior Floor 2					
Heat Fuel	02	Oil			
Heat Type	05	Hot Water			
AC Type	01	None			
Bedrooms	03	3 Bedrooms			
Full Baths	2				
Half Baths	0				
Extra Fixtures					
Total Rooms	8	8 Rooms			
Bath Style					
Kitchen Style					
Occupancy					
Usrflid 105					
Accessory Apt					
Foundation Alt	01	Poured Conc.			
Rms Prts					
Bath Split	20	2 Full-0 Half			

CONDO DATA			
Parcel Id		C	Owne 0.0
Adjust Type	Code	Description	Factor%
Condo Flr			
Condo Unit			

COST / MARKET VALUATION		
Building Value New		421,411
Year Built		1964
Effective Year Built		1988
Depreciation Code		A
Remodel Rating		
Year Remodeled		
Depreciation %		24
Functional Obsol		0
External Obsol		0
Trend Factor		1
Condition		
Condition %		
Percent Good		76
RCNLD		320,300
Dep % Ovr		
Dep Ovr Comment		
Misc Imp Ovr		
Misc Imp Ovr Comment		
Cost to Cure Ovr		
Cost to Cure Ovr Comment		

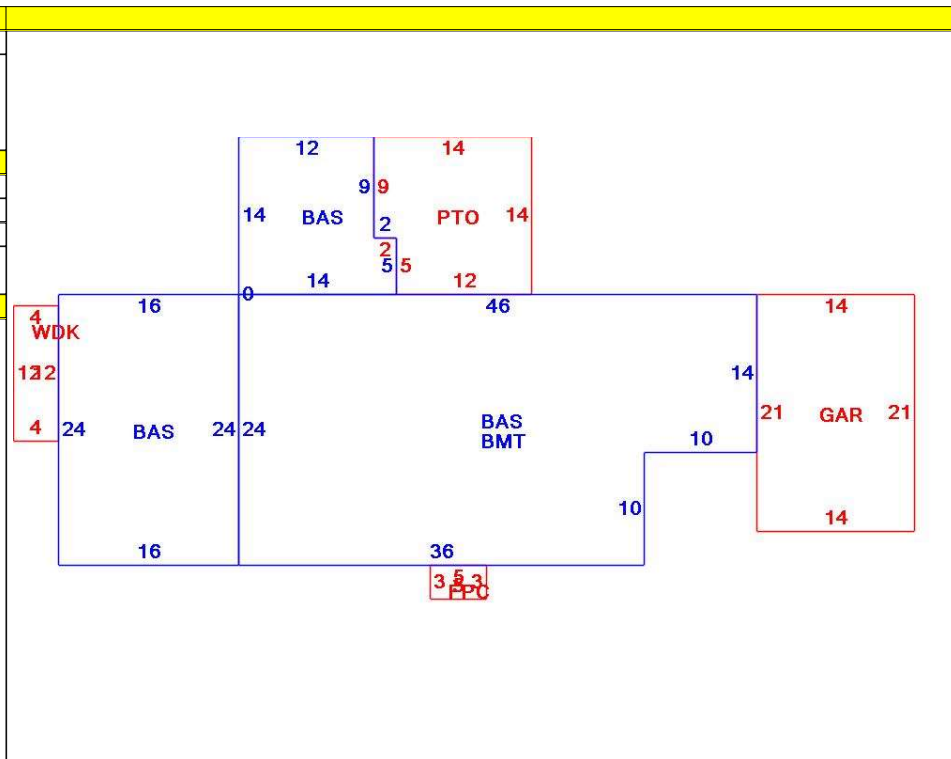

OB - OUTBUILDING & YARD ITEMS(L) / XF - BUILDING EXTRA FEATURES(B)										
Code	Description	L/B	Units	Unit Price	Yr Blt	Cond. Cd	% Gd	Grade	Grade Adj.	Appr. Value
FPL1	Fireplace 1 sto	B	1	5000.00	1990		76		0.00	3,800
PAT1	Patio- Average	L	186	5.89	1994		75		0.00	900
GAR	Attached Gara	B	294	40.00	1990		76		0.00	10,000
BMT	Basement-Unfi	B	1,004	26.01	1990		76		0.00	20,200
FOPC	Open Prch-roo	B	15	55.00	1990		76		0.00	900
WDC	Wood Decking	L	48	20.00	2015		92		0.00	2,500

BUILDING SUB-AREA SUMMARY SECTION						
Code	Description	Living Area	Floor Area	Eff Area	Unit Cost	Undeprec Value
BAS	First Floor	1,566	1,566	1,566	269.10	421,411
BMT	Basement Area	0	1,004	0	0.00	0
FPC	Open Porch Conc. Floor	0	15	0	0.00	0
GAR	Attached Garage	0	294	0	0.00	0
PTO	Patio	0	186	0	0.00	0
WDK	Wood Deck	0	48	0	0.00	0
Ttl Gross Liv / Lease Area		1,566	3,113	1,566		421,411

