

CURRENT OWNER		TOPO	UTILITIES	STRT / ROAD	LOCATION	CURRENT ASSESSMENT			
FLYNN, DOUGLAS		1 Level	1 All Public	1 Paved		Description	Code	Assessed	Assessed
385 BEARSES WAY			4 Gas			RESIDNTL	1010	306,100	306,100
HYANNIS MA 02601		SUPPLEMENTAL DATA				RES LAND	1010	134,100	134,100
Alt Prcl ID		Plan Ref. 65/101			801 FY2024 BARNSTABLE, MA <h1 style="text-align: center;">VISION</h1>				
Split Zonin		Land Ct#							
BID Parcel		#SR							
ResExpt Q YES:		Life Estate							
#DL 1		PP STATU			Total 440,200 440,200				
#DL 2		Assoc Pid#							
GIS ID F_984823_2703666									

RECORD OF OWNERSHIP		BK-VOL/PAGE	SALE DATE	Q/U	V/I	SALE PRIC	VC	PREVIOUS ASSESSMENTS (HISTORY)					
FLYNN, DOUGLAS		1707 0089	08-18-1972	U	V	0		Year	Code	Assessed	Year	Code	Assessed
								2023	1010	271,400	2022	1010	227,600
									1010	128,700		1010	95,300
								Total		400,100	Total		322,900
								Total			Total		284,300

EXEMPTIONS				OTHER ASSESSMENTS				This signature acknowledges a visit by a Data Collector or Assessor				
Year	Code	Description	Amount	Code	Description	Number	Amount	Comm Int				
2010	5C	RESIDENTIAL EXEMPTION	0.00									
Total			0.00									

ASSESSING NEIGHBORHOOD				APPRaised VALUE SUMMARY			
Nbhd	Nbhd Name	B	Tracing	Batch			
0104				HYAN	Appraised Bldg. Value (Card)	274,800	
					Appraised Xf (B) Value (Bldg)	31,300	
					Appraised Ob (B) Value (Bldg)	0	
					Appraised Land Value (Bldg)	134,100	
					Special Land Value	0	
					Total Appraised Parcel Value	440,200	
					Valuation Method	C	
					Total Appraised Parcel Value	440,200	

NOTES										VISIT / CHANGE HISTORY					
										Date	Id	Type	Is	Cd	Purpost/Result
										05-26-2021	BM	03		16	In Office Review
										05-04-2020	WD			FR	Field Review
										11-13-2017	SR	02		03	Cycl Insp Comp
										06-20-2014	JR	03		16	In Office Review
										08-05-2004	MF	04		44	Drive by inspection only
										02-28-2001	SM	01		00	Meas/Listed-Interior Acces
										01-15-1989	ME	02		01	Meas/Est

BUILDING PERMIT RECORD										LAND LINE VALUATION SECTION					
Permit Id	Issue Date	Type	Description	Amount	Insp Date	% Comp	Date Comp	Comments							
76476	05-07-2004	NR	New Roof	4,000	08-05-2004	100	01-01-2005								
B29539	06-01-1986	AD	Addition	10,000	01-15-1989	100		HY ADD'N							

B	Use Code	Description	Zone	LA	Land Units	Unit Price	Size Adj	AC Disc	Site Index	Cond.	Nbhd.	Nbhd. Adj	Notes	Location Adjustmen	Adj Unit P	Land Value
1	1010	Single Fam M-0	RB	4	0.250 AC	176,344.00	3.37919	1.0000	5	1.00	0104	0.900		1.0000	536,315.0	134,100
Total Card Land Units					0.25	AC	Parcel Total Land Area					0.25	Total Land Value			134,100

CONSTRUCTION DETAIL			CONSTRUCTION DETAIL (CONTINUED)		
Element	Cd	Description	Element	Cd	Description
Style	04	Cape Cod			
Model	01	Residential			
Grade:	C-	Average Minus			
Stories	1.75	1 3/4 Stories			
Exterior Wall 1	14	Wood Shingle			
Exterior Wall 2	25	Vinyl Siding			
Roof Structure	03	Gable/Hip			
Roof Cover	03	Asph/F Gls/Cmp			
Interior Wall 1	05	Drywall			
Interior Wall 2					
Interior Floor 1	14	Carpet			
Interior Floor 2	05	Vinyl/Asphalt			
Heat Fuel	02	Oil			
Heat Type	09	Typical			
AC Type	01	None			
Bedrooms	03	3 Bedrooms			
Full Baths	1				
Half Baths	0				
Extra Fixtures					
Total Rooms	5	5 Rooms			
Bath Style					
Kitchen Style					
Occupancy					
Usrflid 105					
Accessory Apt					
Foundation Alt	01	Poured Conc.			
Rms Prts					
Bath Split	10	1 Full-0 Half			
			CONDO DATA		
			Parcel Id		C
			Owne 0.0		
			B S		
			Adjust Type	Code	Description
			Condo Flr		
			Condo Unit		
			COST / MARKET VALUATION		
			Building Value New 398,298		
			Year Built 1942		
			Effective Year Built 1979		
			Depreciation Code A		
			Remodel Rating		
			Year Remodeled		
			Depreciation % 31		
			Functional Obsol 0		
			External Obsol 0		
			Trend Factor 1		
			Condition		
			Condition %		
			Percent Good 69		
			RCNLD 274,800		
			Dep % Ovr		
			Dep Ovr Comment		
			Misc Imp Ovr		
			Misc Imp Ovr Comment		
			Cost to Cure Ovr		
			Cost to Cure Ovr Comment		

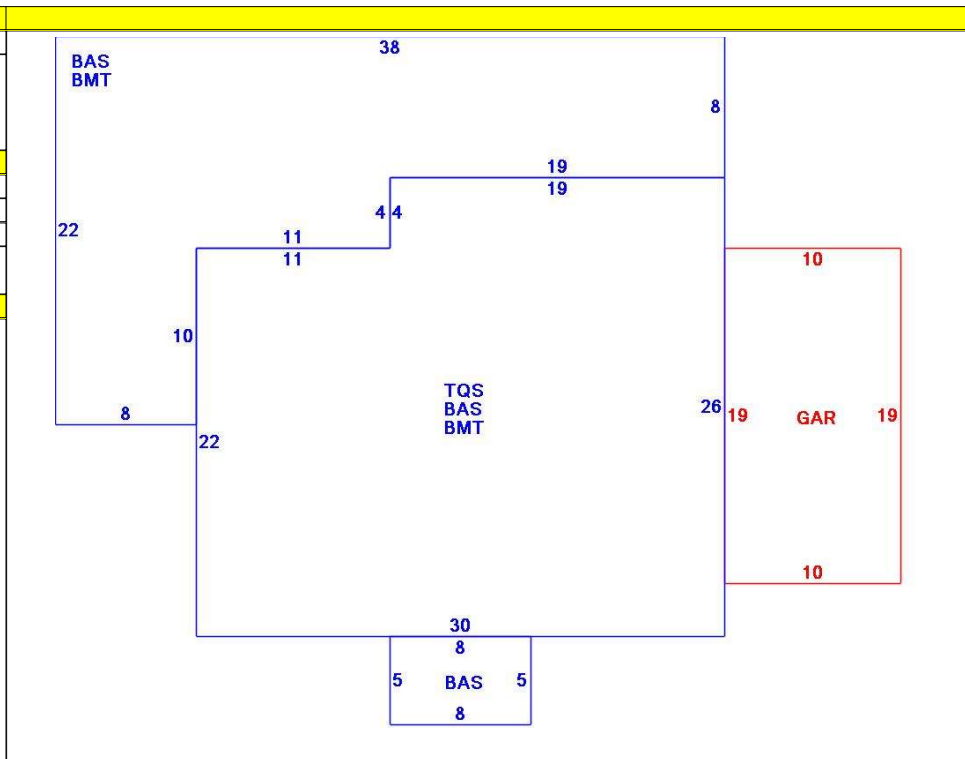

OB - OUTBUILDING & YARD ITEMS(L) / XF - BUILDING EXTRA FEATURES(B)

Code	Description	L/B	Units	Unit Price	Yr Blt	Cond. Cd	% Gd	Grade	Grade Adj.	Appr. Value
FPL2	Fireplace 1.5 s	B	1	6000.00	1979		69		0.00	4,100
GAR	Attached Gara	B	190	40.00	1979		69		0.00	6,600
BMT	Basement-Unfi	B	1,196	26.01	1979		69		0.00	20,600

BUILDING SUB-AREA SUMMARY SECTION

Code	Description	Living Area	Floor Area	Eff Area	Unit Cost	Undeprc Value
BAS	First Floor	1,236	1,236	1,236	232.38	287,221
BMT	Basement Area	0	1,196	0	0.00	0
GAR	Attached Garage	0	190	0	0.00	0
TQS	Three Quarter Story	478	736	478	150.92	111,077
Ttl Gross Liv / Lease Area		1,714	3,358	1,714		398,298

