

CURRENT OWNER				TOPO	UTILITIES	STRT / ROAD	LOCATION	CURRENT ASSESSMENT				
ABASOV, ANAR 122 CENTER STREET # 3 HYANNIS MA 02601				1 Level	6 Septic	1 Paved		Description	Code	Assessed	Assessed	801 FY2024 BARNSTABLE, MA VISION
					4 Gas			RESIDNTL	1010	219,300	219,300	
					2 Public Water			RES LAND	1010	135,300	135,300	
SUPPLEMENTAL DATA								Total		354,600	354,600	
Alt Prcl ID				Split Zonin		Plan Ref. 225/109						
BID Parcel				ResExpt Q		Land Ct#						
#DL 1 LOT 36				#DL 2		Life Estate						
GIS ID F_985005_2702901				Assoc Pid#								

RECORD OF OWNERSHIP				BK-VOL/PAGE	SALE DATE	Q/U	V/I	SALE PRIC	VC	PREVIOUS ASSESSMENTS (HISTORY)							
Year	Code	Assessed	Year	Code	Assessed V	Year	Code	Assessed	Year	Code	Assessed	Year	Code	Assessed			
ABASOV, ANAR	30914	0305	11-21-2017	Q	I	165,000	00		2023	1010	185,200	2022	1010	156,300	2021	1010	119,200
PATALANO, PAUL F & ALEXANDER M	28970	0082	06-26-2015	Q	I	150,000	00			1010	129,800		1010	96,100		1010	91,100
ALWARDT, MARY ELLEN & MCINTYRE, S	28970	0078	06-26-2015	U	I	0	1A								1010	4,600	
ALWARDT, MARY ELLEN TR & MCINTYRE, DOROTHY L	8005	0222	05-15-1992	U	I	1	A										
	P0779A1	0	06-15-1987	U	I	1	A										
Total									315,000		Total		252,400	Total		214,900	

EXEMPTIONS				OTHER ASSESSMENTS			
Year	Code	Description	Amount	Code	Description	Number	Amount
Total			0.00				

ASSESSING NEIGHBORHOOD			
Nbhd	Nbhd Name	B	Tracing
0104			HYAN

NOTES			
This signature acknowledges a visit by a Data Collector or Assessor			
APPRAISED VALUE SUMMARY			
Appraised Bldg. Value (Card)			214,700
Appraised Xf (B) Value (Bldg)			0
Appraised Ob (B) Value (Bldg)			4,600
Appraised Land Value (Bldg)			135,300
Special Land Value			0
Total Appraised Parcel Value			354,600
Valuation Method			C
Total Appraised Parcel Value			354,600

BUILDING PERMIT RECORD								VISIT / CHANGE HISTORY						
Permit Id	Issue Date	Type	Description	Amount	Insp Date	% Comp	Date Comp	Comments	Date	Id	Type	Is	Cd	Purpost/Result
									05-04-2020	WD			FR	Field Review
									10-12-2017	KM	02		03	Cycl Insp Comp
									07-03-2017	TR	22		22	Change of Address
									03-01-2001	SM	01		00	Meas/Listed-Interior Acces
									09-15-1987	ML	01		00	Meas/Listed-Interior Acces

LAND LINE VALUATION SECTION																	
B	Use Code	Description	Zone	LA	Land Units	Unit Price	Size Adj	AC Disc	Site Index	Cond.	Nbhd.	Nbhd. Adj	Notes	Location Adjustmen	Adj Unit P	Land Value	
1	1010	Single Fam M-0	RB	4	0.290	AC	176,344.00	2.93869	1.0000	5	1.00	0104	0.900	MKT ADJ	1.0000	466,394.6	135,300
Total Card Land Units					0.29	AC	Parcel Total Land Area					0.29	Total Land Value			135,300	

CONSTRUCTION DETAIL			CONSTRUCTION DETAIL (CONTINUED)		
Element	Cd	Description	Element	Cd	Description
Style	01	Ranch			
Model	01	Residential			
Grade:	C	Average			
Stories	1	1 Story			
Exterior Wall 1	25	Vinyl Siding			
Exterior Wall 2					
RooF Structure	03	Gable/Hip			
RooF Cover	03	Asph/F Gls/Cmp			
Interior Wall 1	04	Plywood Panel			
Interior Wall 2					
Interior Floor 1	14	Carpet			
Interior Floor 2	11	Ceram Clay Til			
Heat Fuel	03	Gas			
Heat Type	04	Hot Air			
AC Type	01	None			
Bedrooms	03	3 Bedrooms			
Full Baths	1				
Half Baths	0				
Extra Fixtures					
Total Rooms	5	5 Rooms			
Bath Style					
Kitchen Style					
Occupancy					
UsrflD 105					
Accessory Apt					
Foundation Alt	03	Conc. Slab			
Rms Prts					
Bath Split	10	1 Full-0 Half			
			CONDO DATA		
			Parcel Id	C	Ownr 0.0
				B	S
			Adjust Type	Code	Description
			Condo Flr		Factor%
			Condo Unit		
			COST / MARKET VALUATION		
			Building Value New		294,143
			Year Built		1945
			Effective Year Built		1984
			Depreciation Code		G
			Remodel Rating		
			Year Remodeled		
			Depreciation %		27
			Functional Obsol		0
			External Obsol		0
			Trend Factor		1
			Condition		
			Condition %		
			Percent Good		73
			RCNLD		214,700
			Dep % Ovr		
			Dep Ovr Comment		
			Misc Imp Ovr		
			Misc Imp Ovr Comment		
			Cost to Cure Ovr		
			Cost to Cure Ovr Comment		

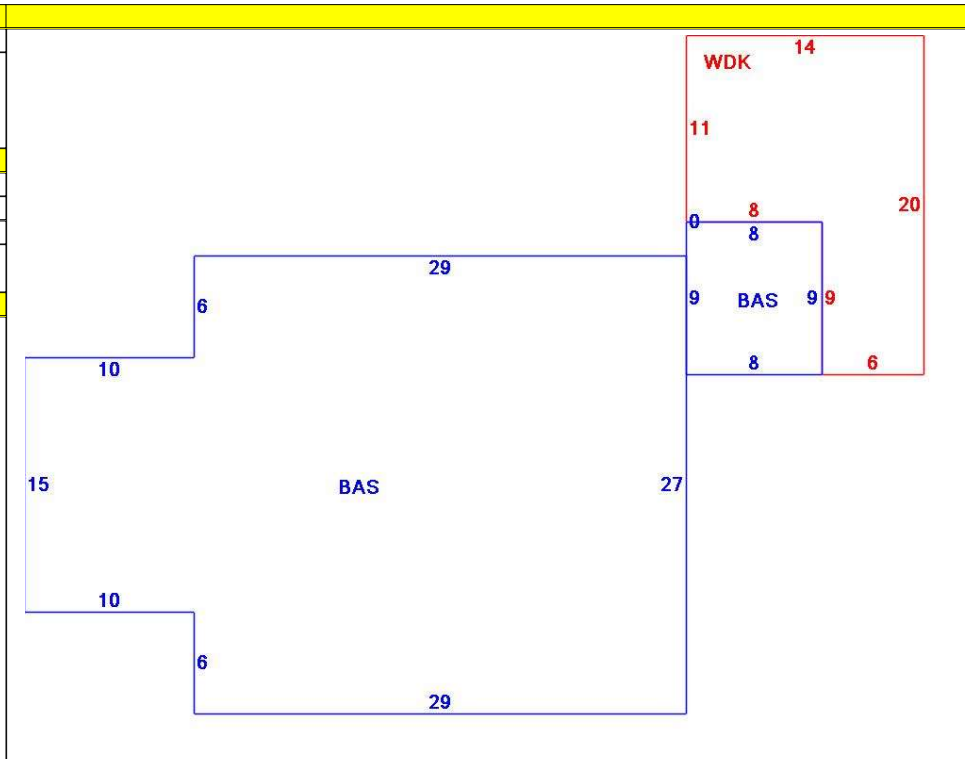

OB - OUTBUILDING & YARD ITEMS(L) / XF - BUILDING EXTRA FEATURES(B)										
Code	Description	L/B	Units	Unit Price	Yr Blt	Cond. Cd	% Gd	Grade	Grade Adj.	Appr. Value
WDC	Wood Decking	L	208	20.00	2017		96		0.00	4,600

BUILDING SUB-AREA SUMMARY SECTION							
Code	Description	Living Area	Floor Area	Eff Area	Unit Cost	Undeprec Value	
BAS	First Floor	1,005	1,005	1,005	292.68	294,143	
WDC	Wood Deck	0	208	0	0.00	0	
Ttl Gross Liv / Lease Area		1,005	1,213	1,005		294,143	

