

CONSTRUCTION DETAIL			CONSTRUCTION DETAIL (CONTINUED)		
Element	Cd	Description	Element	Cd	Description
Style	06	Conventional			
Model	01	Residential			
Grade:	C+	Average Plus			
Stories	1.5	1 1/2 Stories			
Exterior Wall 1	14	Wood Shingle			
Exterior Wall 2	11	Clapboard			
Roof Structure	03	Gable/Hip			
Roof Cover	03	Asph/F Gls/Cmp			
Interior Wall 1	03	Plastered			
Interior Wall 2					
Interior Floor 1	09	Pine/Soft Wood			
Interior Floor 2					
Heat Fuel	03	Gas			
Heat Type	04	Hot Air			
AC Type	01	None			
Bedrooms	04	4 Bedrooms			
Full Baths	2				
Half Baths	1				
Extra Fixtures					
Total Rooms	7	7 Rooms			
Bath Style					
Kitchen Style					
Occupancy					
Usrflid 105					
Accessory Apt					
Foundation Alt	08	Mixed			
Rms Prts					
Bath Split	21	2 Full-1 Half			

CONDO DATA			
Parcel Id		C	Ownr 0.0
Adjust Type	Code	Description	Factor%
Condo Flr			
Condo Unit			

COST / MARKET VALUATION	
Building Value New	557,443
Year Built	1900
Effective Year Built	1979
Depreciation Code	A
Remodel Rating	
Year Remodeled	
Depreciation %	31
Functional Obsol	0
External Obsol	0
Trend Factor	1
Condition	
Condition %	
Percent Good	69
RCNLD	384,600
Dep % Ovr	
Dep Ovr Comment	
Misc Imp Ovr	
Misc Imp Ovr Comment	
Cost to Cure Ovr	
Cost to Cure Ovr Comment	

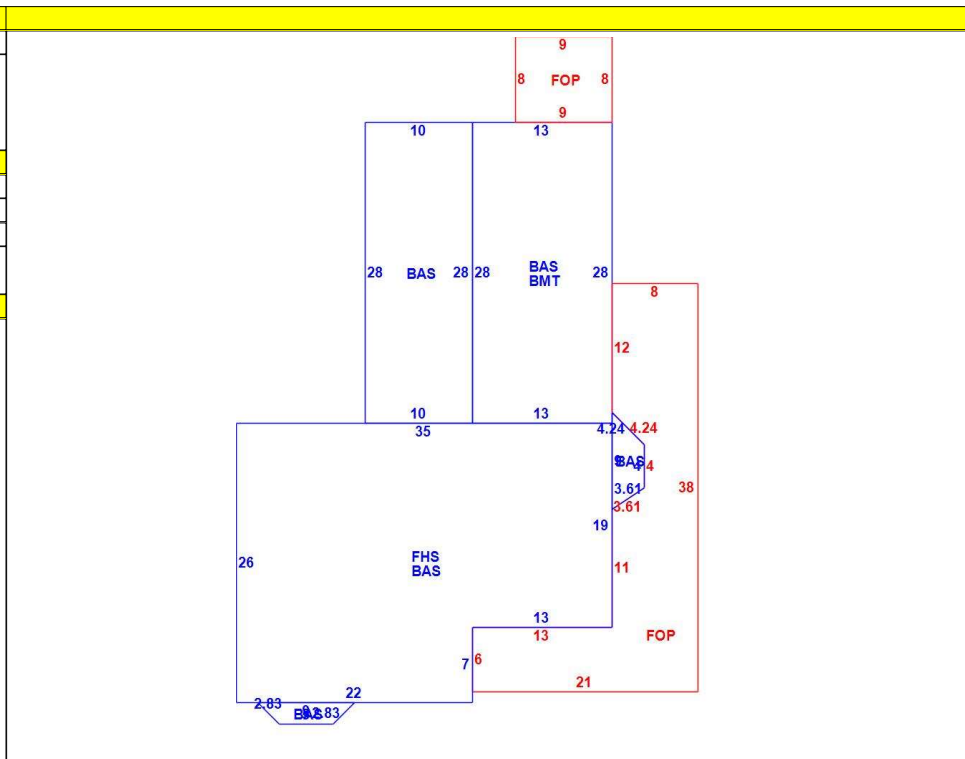

OB - OUTBUILDING & YARD ITEMS(L) / XF - BUILDING EXTRA FEATURES(B)										
Code	Description	L/B	Units	Unit Price	Yr Blt	Cond. Cd	% Gd	Grade	Grade Adj.	Appr. Value
FPL2	Fireplace 1.5 s	B	2	6000.00	1979		69		0.00	8,300
GAR3	Det Gar-w/TQ	L	624	100.00	1986		67	00	1.00	41,800
FOP	Open Porch-ro	B	435	55.00	1979		69		0.00	11,600
BMT	Basement-Unfi	B	364	26.01	1979		69		0.00	9,400

BUILDING SUB-AREA SUMMARY SECTION						
Code	Description	Living Area	Floor Area	Eff Area	Unit Cost	Undeprec Value
BAS	First Floor	1,497	1,497	1,497	292.31	437,594
BMT	Basement Area	0	364	0	0.00	0
FHS	Half Story	410	819	410	146.34	119,849
FOP	Open Porch	0	435	0	0.00	0
Ttl Gross Liv / Lease Area		1,907	3,115	1,907		557,443

