

| CURRENT OWNER | | TOPO | UTILITIES | STRT / ROAD | LOCATION | CURRENT ASSESSMENT | | | |
|---|--|--|----------------|--|----------|-----------------------|------|----------|----------|
| BRYANT, WILLIAM B & KATHLEEN M 2020 BRYANT FAMILY LIVING TRUST 288 CARRIAGE LANE BARNSTABLE MA 02630 | | 2 Above Street | 6 Septic | 1 Paved | | Description | Code | Assessed | Assessed |
| | | | 4 Gas | | | RESIDNTL | 1010 | 446,600 | 446,600 |
| | | | 2 Public Water | | | RES LAND | 1010 | 199,800 | 199,800 |
| SUPPLEMENTAL DATA | | | | | | | | | |
| | | Alt Prcl ID Split Zonin BID Parcel ResExpt Q YES: #DL 1 LOT 49 #DL 2 GIS ID F_984654_2714032 | | Plan Ref. 260/42 Land Ct# #SR Life Estate PP STATU Assoc Pid# | | Total 646,400 646,400 | | | |

801
 FY2024
 BARNSTABLE, MA
VISION

| RECORD OF OWNERSHIP | | BK-VOL/PAGE | SALE DATE | Q/U | V/I | SALE PRIC | VC | PREVIOUS ASSESSMENTS (HISTORY) | | | | | |
|------------------------------------|-------|-------------|------------|-----|-----|-----------|----|--------------------------------|------|----------|-------|------|----------|
| BRYANT, WILLIAM B & KATHLEEN M TRS | 32717 | 0320 | 02-27-2020 | U | I | 10 | 1F | Year | Code | Assessed | Year | Code | Assessed |
| BRYANT, WILLIAM B & KATHLEEN MARG | 30628 | 0003 | 07-14-2017 | Q | I | 390,000 | 00 | 2023 | 1010 | 385,900 | 2022 | 1010 | 334,600 |
| THURBER, KENNETH R & SHARYN L TR | 27394 | 0122 | 05-21-2013 | U | I | 1 | 1F | | 1010 | 197,400 | | 1010 | 140,400 |
| THURBER, KENNETH R & SHARYN L | 11787 | 0156 | 10-26-1998 | Q | I | 185,000 | 00 | | | | | 1010 | 5,300 |
| DEASY, JOHN J & DOROTHY J | 4080 | 0304 | 04-15-1984 | Q | I | 100,000 | U | Total | | 583,300 | Total | | 475,000 |
| | | | | | | | | Total | | 417,500 | Total | | 417,500 |

| EXEMPTIONS | | | | OTHER ASSESSMENTS | | | |
|------------|------|-----------------------|--------|-------------------|-------------|--------|--------|
| Year | Code | Description | Amount | Code | Description | Number | Amount |
| 2022 | 5C | RESIDENTIAL EXEMPTION | 0.00 | | | | |
| Total | | | 0.00 | | | | |

This signature acknowledges a visit by a Data Collector or Assessor

| ASSESSING NEIGHBORHOOD | | | |
|------------------------|-----------|---|---------|
| Nbhd | Nbhd Name | B | Tracing |
| 0106 | | | BARNS |

| APPRAISED VALUE SUMMARY | |
|-------------------------------|---------|
| Appraised Bldg. Value (Card) | 381,900 |
| Appraised Xf (B) Value (Bldg) | 59,400 |
| Appraised Ob (B) Value (Bldg) | 5,300 |
| Appraised Land Value (Bldg) | 199,800 |
| Special Land Value | 0 |
| Total Appraised Parcel Value | 646,400 |
| Valuation Method | C |
| Total Appraised Parcel Value | 646,400 |

| NOTES | | | | | | | |
|-------|--|--|--|--|--|--|--|
| | | | | | | | |

| BUILDING PERMIT RECORD | | | | | | | | VISIT / CHANGE HISTORY | | | | | | | |
|------------------------|--------------------------|------------|---------------------------------|------------|------------|------------|------------|---|--|----------------------------------|----------------------------|----|----------------------------------|--|--|
| Permit Id | Issue Date | Type | Description | Amount | Insp Date | % Comp | Date Comp | Comments | Date | Id | Type | Is | Cd | Purpost/Result | |
| EXPR-22-5 19-664 | 04-27-2022 03-01-2019 | 835 833 | Sid/Wind/Roof/ Shd-Res-under | 4,600 0 | 05-24-2019 | 100 100 | 06-30-2019 | Install 1423 SF of cellulose in 10 X 10 SHED | 02-09-2022 05-07-2020 08-12-2019 08-08-2016 10-15-2013 09-23-2000 | AS DM SR SR SR MF | 03 01 01 01 01 | | 16 FR 02 03 14 00 | In Office Review Field Review Bldg Permit Completed Cycl Insp Comp Cyclical Inspection Meas/Listed-Interior Acces | |

| LAND LINE VALUATION SECTION | | | | | | | | | | | | | | | | | |
|-----------------------------|----------|----------------|------|----|------------|------------|------------------------|---------|------------|-------|-------|-----------|------------------|--------------------|------------|------------|--|
| B | Use Code | Description | Zone | LA | Land Units | Unit Price | Size Adj | AC Disc | Site Index | Cond. | Nbhd. | Nbhd. Adj | Notes | Location Adjustmen | Adj Unit P | Land Value | |
| 1 | 1010 | Single Fam M-0 | RF-1 | 1 | 0.840 AC | 176,344.00 | 1.17279 | 1.0000 | 5 | 1.00 | 0106 | 1.150 | | 1.0000 | 237,835.1 | 199,800 | |
| Total Card Land Units | | | | | 0.84 | AC | Parcel Total Land Area | | | | | 0.84 | Total Land Value | | | 199,800 | |

| CONSTRUCTION DETAIL | | | CONSTRUCTION DETAIL (CONTINUED) | | |
|---------------------|----|----------------|---------------------------------|----|-------------|
| Element | Cd | Description | Element | Cd | Description |
| Style | 01 | Ranch | | | |
| Model | 01 | Residential | | | |
| Grade: | C+ | Average Plus | | | |
| Stories | 1 | 1 Story | | | |
| Exterior Wall 1 | 14 | Wood Shingle | | | |
| Exterior Wall 2 | 25 | Vinyl Siding | | | |
| RooF Structure | 03 | Gable/Hip | | | |
| RooF Cover | 03 | Asph/F Gls/Cmp | | | |
| Interior Wall 1 | 05 | Drywall | | | |
| Interior Wall 2 | | | | | |
| Interior Floor 1 | 14 | Carpet | | | |
| Interior Floor 2 | | | | | |
| Heat Fuel | 03 | Gas | | | |
| Heat Type | 05 | Hot Water | | | |
| AC Type | 03 | Central | | | |
| Bedrooms | 02 | 2 Bedrooms | | | |
| Full Baths | 3 | | | | |
| Half Baths | 0 | | | | |
| Extra Fixtures | | | | | |
| Total Rooms | 5 | 5 Rooms | | | |
| Bath Style | | | | | |
| Kitchen Style | | | | | |
| Occupancy | | | | | |
| Usrflid 105 | | | | | |
| Accessory Apt | | | | | |
| Foundation Alt | 01 | Poured Conc. | | | |
| Rms Prts | | | | | |
| Bath Split | 30 | 3 Full-0 Half | | | |

| CONDO DATA | | | |
|-------------|------|-------------|----------|
| Parcel Id | | C | Ownr 0.0 |
| | | B | S |
| Adjust Type | Code | Description | Factor% |
| Condo Flr | | | |
| Condo Unit | | | |

| COST / MARKET VALUATION | |
|--------------------------|---------|
| Building Value New | 454,673 |
| Year Built | 1984 |
| Effective Year Built | 1998 |
| Depreciation Code | A |
| Remodel Rating | |
| Year Remodeled | |
| Depreciation % | 16 |
| Functional Obsol | 0 |
| External Obsol | 0 |
| Trend Factor | 1 |
| Condition | |
| Condition % | |
| Percent Good | 84 |
| RCNLD | 381,900 |
| Dep % Ovr | |
| Dep Ovr Comment | |
| Misc Imp Ovr | |
| Misc Imp Ovr Comment | |
| Cost to Cure Ovr | |
| Cost to Cure Ovr Comment | |

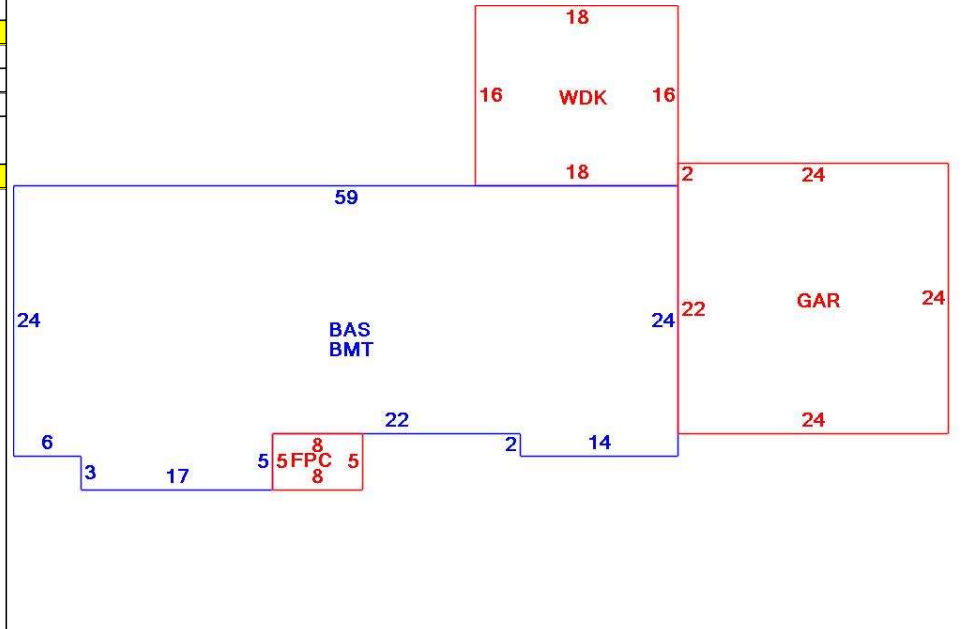

| OB - OUTBUILDING & YARD ITEMS(L) / XF - BUILDING EXTRA FEATURES(B) | | | | | | | | | | |
|--|-----------------|-----|-------|------------|--------|----------|------|-------|------------|-------------|
| Code | Description | L/B | Units | Unit Price | Yr Blt | Cond. Cd | % Gd | Grade | Grade Adj. | Appr. Value |
| FPL1 | Fireplace 1 sto | B | 1 | 5000.00 | 2000 | | 84 | | 0.00 | 4,200 |
| BRR | Bsmt Rec Rm- | B | 1,065 | 8.05 | 2000 | | 84 | | 0.00 | 7,200 |
| WDC | Wood Decking | L | 288 | 20.00 | 1999 | | 60 | | 0.00 | 3,500 |
| FOPC | Open Prch-roo | B | 40 | 55.00 | 2000 | | 84 | | 0.00 | 2,100 |
| GAR | Attached Gara | B | 576 | 40.00 | 2000 | | 84 | | 0.00 | 17,200 |
| BMT | Basement-Unfi | B | 1,423 | 26.01 | 2000 | | 84 | | 0.00 | 28,700 |
| SHED | Shed | L | 100 | 18.00 | 2019 | | 100 | | 0.00 | 1,800 |

| BUILDING SUB-AREA SUMMARY SECTION | | | | | | |
|-----------------------------------|------------------------|-------------|------------|----------|-----------|----------------|
| Code | Description | Living Area | Floor Area | Eff Area | Unit Cost | Undeprec Value |
| BAS | First Floor | 1,423 | 1,423 | 1,423 | 319.52 | 454,673 |
| BMT | Basement Area | 0 | 1,423 | 0 | 0.00 | 0 |
| FPC | Open Porch Conc. Floor | 0 | 40 | 0 | 0.00 | 0 |
| GAR | Attached Garage | 0 | 576 | 0 | 0.00 | 0 |
| WDK | Wood Deck | 0 | 288 | 0 | 0.00 | 0 |
| Ttl Gross Liv / Lease Area | | 1,423 | 3,750 | 1,423 | | 454,673 |

