

| CURRENT OWNER                                                                                                  |  | TOPO    | UTILITIES      | STRT / ROAD                                                                                   | LOCATION | CURRENT ASSESSMENT |      |          |          | 801<br>FY2024<br>BARNSTABLE, MA<br><br><b>VISION</b> |
|----------------------------------------------------------------------------------------------------------------|--|---------|----------------|-----------------------------------------------------------------------------------------------|----------|--------------------|------|----------|----------|------------------------------------------------------|
| FOLEY, WILLIAM F JR & FRANCES D<br>FOLEY FAMILY TRUST<br>PO BOX 1198<br><br>BARNSTABLE MA 02630                |  | 1 Level | 6 Septic       | 1 Paved                                                                                       |          | Description        | Code | Assessed | Assessed |                                                      |
|                                                                                                                |  |         | 4 Gas          |                                                                                               |          | RESIDNTL           | 1010 | 630,200  | 630,200  |                                                      |
|                                                                                                                |  |         | 2 Public Water |                                                                                               |          | RES LAND           | 1010 | 179,600  | 179,600  |                                                      |
| <b>SUPPLEMENTAL DATA</b>                                                                                       |  |         |                |                                                                                               |          | Total              |      |          |          | 809,800                                              |
| Alt Prcl ID<br>Split Zonin<br>BID Parcel<br>ResExpt Q YES:<br>#DL 1 LOT 35<br>#DL 2<br>GIS ID F_984584_2716731 |  |         |                | Plan Ref. 260/42 (SH 2)<br>Land Ct#<br>#SR<br>Life Estate<br>PP STATU D:Deleted<br>Assoc Pid# |          |                    |      |          |          |                                                      |

| RECORD OF OWNERSHIP                |  | BK-VOL/PAGE | SALE DATE  | Q/U | V/I | SALE PRIC | VC | PREVIOUS ASSESSMENTS (HISTORY) |      |          |       |      |          |
|------------------------------------|--|-------------|------------|-----|-----|-----------|----|--------------------------------|------|----------|-------|------|----------|
| FOLEY, WILLIAM F JR & FRANCES D TR |  | 28226 0338  | 06-26-2014 | Q   | I   | 410,000   | 00 | Year                           | Code | Assessed | Year  | Code | Assessed |
| HARDACRE, JOHN J & LYNNE M         |  | 27248 0058  | 03-29-2013 | U   | I   | 260,000   | 1  | 2023                           | 1010 | 540,600  | 2022  | 1010 | 470,300  |
| AUCOIN, JAN EXECUTRIX              |  | 27248 0057  | 03-29-2013 | U   | I   | 0         | 1  |                                | 1010 | 177,500  |       | 1010 | 126,200  |
| KELLY, PAUL F                      |  | 25175 0179  | 01-11-2011 | U   | I   | 1         | 1A |                                |      |          |       | 1010 | 8,900    |
| KELLY, PAUL F                      |  | 25175 0178  | 01-11-2011 | U   | I   | 0         | 1  | Total                          |      | 718,100  | Total |      | 596,500  |
|                                    |  |             |            |     |     |           |    | Total                          |      |          | Total |      | 510,000  |

| EXEMPTIONS |      |                       | OTHER ASSESSMENTS |      |             |        |        | This signature acknowledges a visit by a Data Collector or Assessor |  |  |  |  |  |  |
|------------|------|-----------------------|-------------------|------|-------------|--------|--------|---------------------------------------------------------------------|--|--|--|--|--|--|
| Year       | Code | Description           | Amount            | Code | Description | Number | Amount | Comm Int                                                            |  |  |  |  |  |  |
| 2024       | 5C   | RESIDENTIAL EXEMPTION |                   |      |             |        |        |                                                                     |  |  |  |  |  |  |
| Total      |      |                       | 0.00              |      |             |        |        |                                                                     |  |  |  |  |  |  |

| ASSESSING NEIGHBORHOOD |           |   |         | APPRAISED VALUE SUMMARY |                               |         |  |
|------------------------|-----------|---|---------|-------------------------|-------------------------------|---------|--|
| Nbhd                   | Nbhd Name | B | Tracing | Batch                   |                               |         |  |
| 0106                   |           |   |         | BARNS                   | Appraised Bldg. Value (Card)  | 563,100 |  |
|                        |           |   |         |                         | Appraised Xf (B) Value (Bldg) | 58,200  |  |
|                        |           |   |         |                         | Appraised Ob (B) Value (Bldg) | 8,900   |  |
|                        |           |   |         |                         | Appraised Land Value (Bldg)   | 179,600 |  |
|                        |           |   |         |                         | Special Land Value            | 0       |  |
|                        |           |   |         |                         | Total Appraised Parcel Value  | 809,800 |  |
|                        |           |   |         |                         | Valuation Method              | C       |  |
|                        |           |   |         |                         | Total Appraised Parcel Value  | 809,800 |  |

| NOTES |  |  |  |  |  |  |  |  | VISIT / CHANGE HISTORY |    |      |    |    |                   |
|-------|--|--|--|--|--|--|--|--|------------------------|----|------|----|----|-------------------|
|       |  |  |  |  |  |  |  |  | Date                   | Id | Type | Is | Cd | Purpost/Result    |
|       |  |  |  |  |  |  |  |  | 07-19-2023             | JO | 03   |    | 16 | In Office Review  |
|       |  |  |  |  |  |  |  |  | 03-03-2022             | BM | 22   |    | 22 | Change of Address |
|       |  |  |  |  |  |  |  |  | 05-07-2020             | DM |      |    | FR | Field Review      |
|       |  |  |  |  |  |  |  |  | 08-18-2016             | SR | 02   |    | 03 | Cycl Insp Comp    |
|       |  |  |  |  |  |  |  |  | 10-09-2015             | AL | 22   |    | 22 | Change of Address |
|       |  |  |  |  |  |  |  |  | 08-19-2015             | TP | 03   |    | 16 | In Office Review  |
|       |  |  |  |  |  |  |  |  | 08-05-2015             | JR | 03   |    | 20 | Sale Review       |

| BUILDING PERMIT RECORD |            |      |             |        |            |        |            |                 | LAND LINE VALUATION SECTION |          |                |      |    |            |            |          |         |            |       |       |           |       |                    |            |            |
|------------------------|------------|------|-------------|--------|------------|--------|------------|-----------------|-----------------------------|----------|----------------|------|----|------------|------------|----------|---------|------------|-------|-------|-----------|-------|--------------------|------------|------------|
| Permit Id              | Issue Date | Type | Description | Amount | Insp Date  | % Comp | Date Comp  | Comments        | B                           | Use Code | Description    | Zone | LA | Land Units | Unit Price | Size Adj | AC Disc | Site Index | Cond. | Nbhd. | Nbhd. Adj | Notes | Location Adjustmen | Adj Unit P | Land Value |
| 201100039              | 03-08-2011 | RE   | Remodel     | 75,000 | 01-08-2013 | 100    | 06-30-2011 | REMODEL CEILING | 1                           | 1010     | Single Fam M-0 | RF-2 | 1  | 0.470      | AC         | 1.88432  | 1.0000  | 5          | 1.00  | 0106  | 1.150     |       | 1.0000             | 382,137.4  | 179,600    |
| 33862                  | 10-06-1998 | AD   | Addition    | 25,000 | 06-30-1999 | 100    | 06-30-1999 | GAR 2CAR 20X28  |                             |          |                |      |    |            |            |          |         |            |       |       |           |       |                    |            |            |

| TOTAL SUMMARY         |  |  |  |  |  |  |  |  |  |  |  |      |    |                        |  |  |  |  |  |  |  |  |  |  |  |      |                  |  |  |  |  |  |         |
|-----------------------|--|--|--|--|--|--|--|--|--|--|--|------|----|------------------------|--|--|--|--|--|--|--|--|--|--|--|------|------------------|--|--|--|--|--|---------|
| Total Card Land Units |  |  |  |  |  |  |  |  |  |  |  | 0.47 | AC | Parcel Total Land Area |  |  |  |  |  |  |  |  |  |  |  | 0.47 | Total Land Value |  |  |  |  |  | 179,600 |

| CONSTRUCTION DETAIL |    |                | CONSTRUCTION DETAIL (CONTINUED) |    |             |
|---------------------|----|----------------|---------------------------------|----|-------------|
| Element             | Cd | Description    | Element                         | Cd | Description |
| Style               | 01 | Ranch          |                                 |    |             |
| Model               | 01 | Residential    |                                 |    |             |
| Grade:              | B- | Custom Minus   |                                 |    |             |
| Stories             | 1  | 1 Story        |                                 |    |             |
| Exterior Wall 1     | 14 | Wood Shingle   |                                 |    |             |
| Exterior Wall 2     | 11 | Clapboard      |                                 |    |             |
| RooF Structure      | 03 | Gable/Hip      |                                 |    |             |
| RooF Cover          | 03 | Asph/F Gls/Cmp |                                 |    |             |
| Interior Wall 1     | 05 | Drywall        |                                 |    |             |
| Interior Wall 2     |    |                |                                 |    |             |
| Interior Floor 1    | 12 | Hardwood       |                                 |    |             |
| Interior Floor 2    |    |                |                                 |    |             |
| Heat Fuel           | 03 | Gas            |                                 |    |             |
| Heat Type           | 05 | Hot Water      |                                 |    |             |
| AC Type             | 03 | Central        |                                 |    |             |
| Bedrooms            | 02 | 2 Bedrooms     |                                 |    |             |
| Full Baths          | 2  |                |                                 |    |             |
| Half Baths          | 0  |                |                                 |    |             |
| Extra Fixtures      |    |                |                                 |    |             |
| Total Rooms         | 6  | 6 Rooms        |                                 |    |             |
| Bath Style          |    |                |                                 |    |             |
| Kitchen Style       |    |                |                                 |    |             |
| Occupancy           |    |                |                                 |    |             |
| Usrflid 105         |    |                |                                 |    |             |
| Accessory Apt       |    |                |                                 |    |             |
| Foundation Alt      | 01 | Poured Conc.   |                                 |    |             |
| Rms Prts            |    |                |                                 |    |             |
| Bath Split          | 20 | 2 Full-0 Half  |                                 |    |             |

| CONDO DATA  |      |             |          |
|-------------|------|-------------|----------|
| Parcel Id   |      | C           | Owne 0.0 |
| Adjust Type | Code | Description | Factor%  |
| Condo Flr   |      |             |          |
| Condo Unit  |      |             |          |

| COST / MARKET VALUATION  |  |         |
|--------------------------|--|---------|
| Building Value New       |  | 632,683 |
| Year Built               |  | 1978    |
| Effective Year Built     |  | 2005    |
| Depreciation Code        |  | VG      |
| Remodel Rating           |  |         |
| Year Remodeled           |  |         |
| Depreciation %           |  | 11      |
| Functional Obsol         |  | 0       |
| External Obsol           |  | 0       |
| Trend Factor             |  | 1       |
| Condition                |  |         |
| Condition %              |  |         |
| Percent Good             |  | 89      |
| RCNLD                    |  | 563,100 |
| Dep % Ovr                |  |         |
| Dep Ovr Comment          |  |         |
| Misc Imp Ovr             |  |         |
| Misc Imp Ovr Comment     |  |         |
| Cost to Cure Ovr         |  |         |
| Cost to Cure Ovr Comment |  |         |

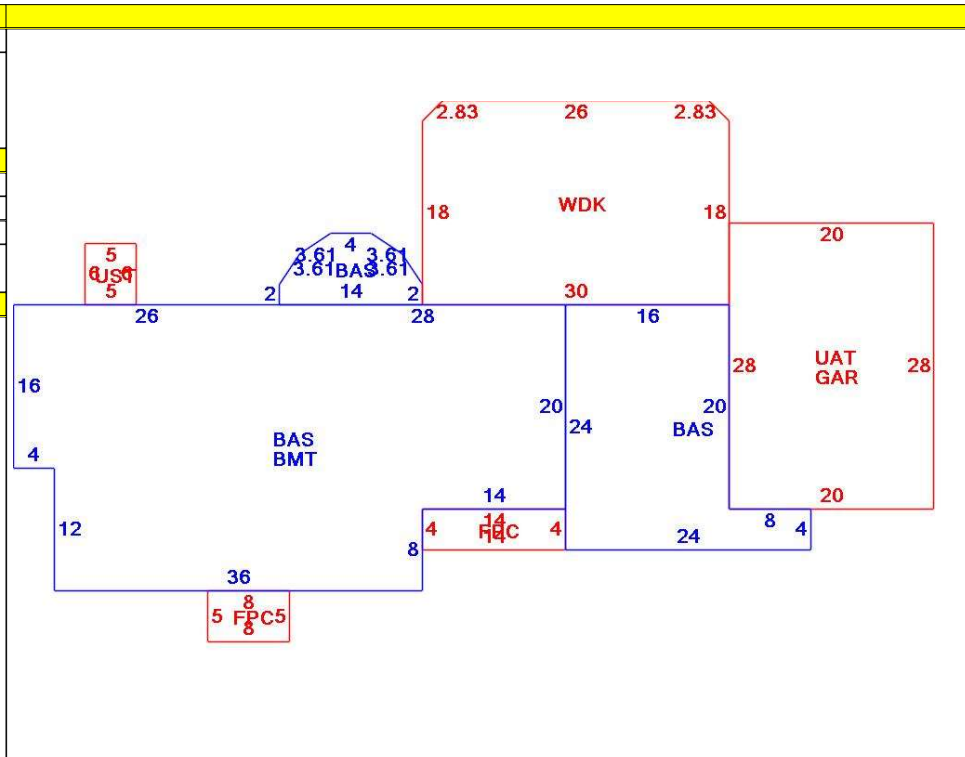

| OB - OUTBUILDING & YARD ITEMS(L) / XF - BUILDING EXTRA FEATURES(B) |                  |     |       |            |        |          |      |       |            |             |
|--------------------------------------------------------------------|------------------|-----|-------|------------|--------|----------|------|-------|------------|-------------|
| Code                                                               | Description      | L/B | Units | Unit Price | Yr Blt | Cond. Cd | % Gd | Grade | Grade Adj. | Appr. Value |
| FPL1                                                               | Fireplace 1 sto  | B   | 1     | 5000.00    | 2007   |          | 89   |       | 0.00       | 4,500       |
| WDC                                                                | Wood Decking     | L   | 596   | 20.00      | 2002   |          | 66   |       | 0.00       | 7,300       |
| FOPC                                                               | Open Prch-roo    | B   | 96    | 55.00      | 2007   |          | 89   |       | 0.00       | 4,000       |
| GAR                                                                | Attached Gara    | B   | 560   | 40.00      | 2007   |          | 89   |       | 0.00       | 17,800      |
| BMT                                                                | Basement-Unfi    | B   | 1,352 | 26.01      | 2007   |          | 89   |       | 0.00       | 29,200      |
| SHED                                                               | Shed             | L   | 128   | 18.00      | 2003   |          | 68   |       | 0.00       | 1,600       |
| UST                                                                | Utility Storage- | B   | 30    | 17.11      | 2007   |          | 89   |       | 0.00       | 500         |
| FPLG                                                               | Gas Fireplace-   | B   | 1     | 2500.00    | 2007   |          | 89   |       | 0.00       | 2,200       |

| BUILDING SUB-AREA SUMMARY SECTION |                        |             |            |          |           |                |
|-----------------------------------|------------------------|-------------|------------|----------|-----------|----------------|
| Code                              | Description            | Living Area | Floor Area | Eff Area | Unit Cost | Undeprec Value |
| BAS                               | First Floor            | 1,846       | 1,846      | 1,846    | 332.64    | 614,055        |
| BMT                               | Basement Area          | 0           | 1,352      | 0        | 0.00      | 0              |
| FPC                               | Open Porch Conc. Floor | 0           | 96         | 0        | 0.00      | 0              |
| GAR                               | Attached Garage        | 0           | 560        | 0        | 0.00      | 0              |
| UAT                               | Attic, Unfinished      | 0           | 560        | 56       | 33.26     | 18,628         |
| UST                               | Utility Enclosure      | 0           | 30         | 0        | 0.00      | 0              |
| WDK                               | Wood Deck              | 0           | 596        | 0        | 0.00      | 0              |
| Ttl Gross Liv / Lease Area        |                        | 1,846       | 5,040      | 1,902    |           | 632,683        |

