

CURRENT OWNER			TOPO	UTILITIES	STRT / ROAD	LOCATION	CURRENT ASSESSMENT				801 FY2024 BARNSTABLE, MA VISION		
CODJS LLC 5122 IRVING AVE S	1	Level	2	Public Water	1	Paved	1	Water View	Description	Code		Assessed	Assessed
	4	Gas							RESIDNTL	1010		296,800	296,800
	6	Septic							RES LAND	1010		294,800	294,800
MPLS MN 55419							SUPPLEMENTAL DATA				Total	591,600	591,600
Alt Prcl ID Split Zonin BID Parcel ResExpt Q #DL 1 #DL 2 GIS ID F_983721_2719204			Plan Ref. 211/151 Land Ct# #SR Life Estate PP STATU Assoc Pid#										

RECORD OF OWNERSHIP			BK-VOL/PAGE	SALE DATE	Q/U	V/I	SALE PRIC	VC	PREVIOUS ASSESSMENTS (HISTORY)								
CODJS LLC SHEA, DAVID A 3RD & JUDYA	24756	0129	08-17-2010	U	I	1	1A		Year	Code	Assessed	Year	Code	Assessed	Year	Code	Assessed
	3429	0149	01-15-1982	Q	I	80,000	U	2023	1010	251,100	2022	1010	205,900	2021	1010	171,900	
										1010	291,600		1010	186,800		1010	198,500
																1010	15,200
									Total		542,700	Total		392,700	Total		385,600

EXEMPTIONS				OTHER ASSESSMENTS				This signature acknowledges a visit by a Data Collector or Assessor										
Year	Code	Description	Amount	Code	Description	Number	Amount	Comm Int										
			Total				0.00											
ASSESSING NEIGHBORHOOD								APPRAISED VALUE SUMMARY										
Nbhd	Nbhd Name		B		Tracing		Batch		Appraised Bldg. Value (Card)						263,500			
0107							BARNs		Appraised Xf (B) Value (Bldg)						15,100			
								Appraised Ob (B) Value (Bldg)						18,200				
								Appraised Land Value (Bldg)						294,800				
								Special Land Value						0				
								Total Appraised Parcel Value						591,600				
								Valuation Method						C				
								Total Appraised Parcel Value						591,600				

BUILDING PERMIT RECORD									VISIT / CHANGE HISTORY					
Permit Id	Issue Date	Type	Description	Amount	Insp Date	% Comp	Date Comp	Comments	Date	Id	Type	Is	Cd	Purpost/Result
19-3398	10-11-2019	835	Sid/Wind/Roof/	13,728	06-30-2020	100	06-30-2020	DOORS (2)	06-15-2023	WT	02		03	Cycl Insp Comp
13565	03-01-1996	RE	Remodel	3,000	08-17-1997	100	01-01-1997	French do	01-04-2022	BM	22		22	Change of Address
B37807	05-01-1995	AD	Addition	5,000	01-15-1996	100		BA ALTER.	05-07-2020	DM			FR	Field Review
									02-01-2017	JR	03		20	Sale Review
									09-20-2016	SR	02		03	Cycl Insp Comp

LAND LINE VALUATION SECTION																	
B	Use Code	Description	Zone	LA	Land Units	Unit Price	Size Adj	AC Disc	Site Index	Cond.	Nbhd.	Nbhd. Adj	Notes	Location Adjustmen	Adj Unit P	Land Value	
1	1010	Single Fam M-0	RF-1	1	0.820	AC	176,344.00	1.19913	1.0000	5	1.00	0108	1.700		1.0000	359,477.2	294,800
Total Card Land Units					0.82	AC	Parcel Total Land Area					0.82	Total Land Value			294,800	

CONSTRUCTION DETAIL			CONSTRUCTION DETAIL (CONTINUED)		
Element	Cd	Description	Element	Cd	Description
Style	03	Colonial			
Model	01	Residential			
Grade:	C	Average			
Stories	2.2				
Exterior Wall 1	14	Wood Shingle			
Exterior Wall 2					
RooF Structure	03	Gable/Hip			
RooF Cover	03	Asph/F Gls/Cmp			
Interior Wall 1	08	Typical			
Interior Wall 2					
Interior Floor 1	09	Pine/Soft Wood			
Interior Floor 2					
Heat Fuel	03	Gas			
Heat Type	05	Hot Water			
AC Type	01	None			
Bedrooms	02	2 Bedrooms			
Full Baths	2				
Half Baths	0				
Extra Fixtures					
Total Rooms	6	6 Rooms			
Bath Style					
Kitchen Style					
Occupancy					
Usrflid 105					
Accessory Apt					
Foundation Alt	11	Stone Ftgs			
Rms Prts					
Bath Split	20	2 Full-0 Half			

CONDO DATA				
Parcel Id		C	Owne	0.0
Adjust Type	Code	Description	Factor%	
Condo Flr				
Condo Unit				

COST / MARKET VALUATION	
Building Value New	381,840
Year Built	1820
Effective Year Built	1979
Depreciation Code	A
Remodel Rating	
Year Remodeled	
Depreciation %	31
Functional Obsol	0
External Obsol	0
Trend Factor	1
Condition	
Condition %	
Percent Good	69
RCNLD	263,500
Dep % Ovr	
Dep Ovr Comment	
Misc Imp Ovr	
Misc Imp Ovr Comment	
Cost to Cure Ovr	
Cost to Cure Ovr Comment	

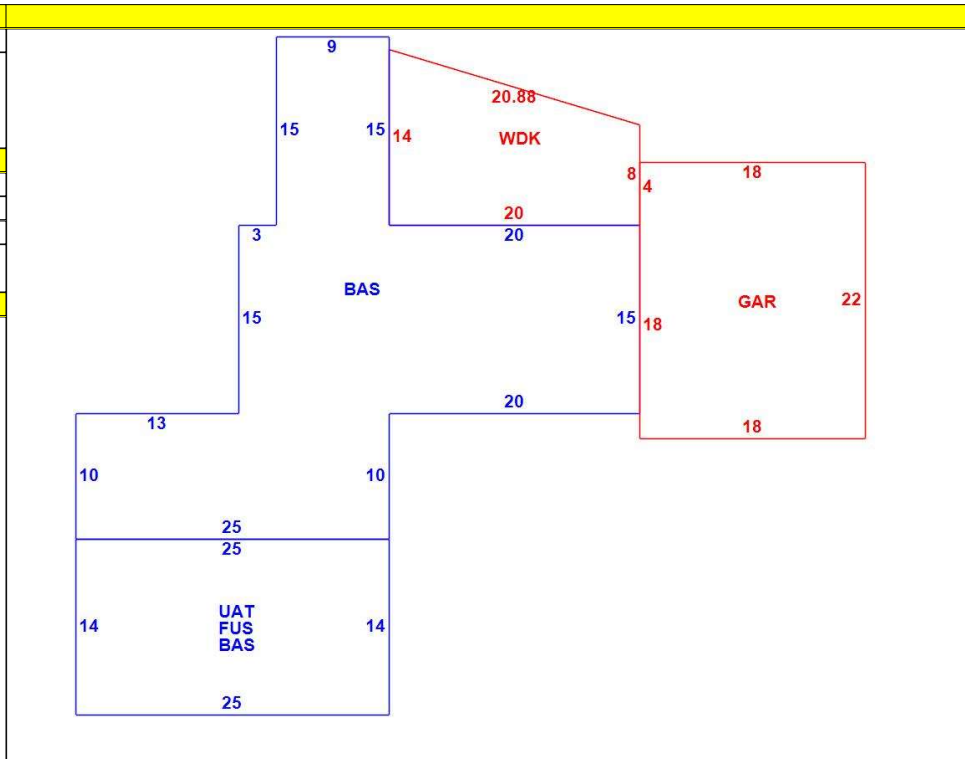

OB - OUTBUILDING & YARD ITEMS(L) / XF - BUILDING EXTRA FEATURES(B)										
Code	Description	L/B	Units	Unit Price	Yr Blt	Cond. Cd	% Gd	Grade	Grade Adj.	Appr. Value
FPL2	Fireplace 1.5 s	B	1	6000.00	1979		69		0.00	4,100
BRN3	Barn w loft	L	480	39.66	1984		65	00	1.00	12,400
WDC	Wood Deck w/	L	220	18.00	2019		100		0.00	4,500
GAR	Attached Gara	B	396	40.00	1979		69		0.00	11,000
WDC	Wood Decking	L	60	20.00	1990		42		0.00	1,300

BUILDING SUB-AREA SUMMARY SECTION						
Code	Description	Living Area	Floor Area	Eff Area	Unit Cost	Undeprec Value
BAS	First Floor	1,215	1,215	1,215	238.65	289,960
FUS	Upper Story	350	350	350	238.65	83,528
GAR	Attached Garage	0	396	0	0.00	0
UAT	Attic, Unfinished	0	350	35	23.87	8,353
WDC	Wood Deck	0	220	0	0.00	0
Ttl Gross Liv / Lease Area		1,565	2,531	1,600		381,841

