

| CURRENT OWNER   |  | TOPO             | UTILITIES      | STRT / ROAD | LOCATION | CURRENT ASSESSMENT |      |          |          | 801<br>FY2024<br>BARNSTABLE, MA<br><br><b>VISION</b> |           |
|---|--|------------------|----------------|-------------|----------|--------------------|------|----------|----------|--|-----------|
| JONES, WARREN T & JEANNE R<br><br>76 DEACON CT<br><br>BARNSTABLE MA 02630 |  | 1 Level          | 2 Public Water | 1 Paved     |          | Description        | Code | Assessed | Assessed |  |           |
|   |  |                  | 4 Gas          |             |          | RESIDNTL           | 1010 | 551,100  | 551,100  |  |           |
|   |  |                  | 6 Septic       |             |          | RES LAND           | 1010 | 555,100  | 555,100  |  |           |
| <b>SUPPLEMENTAL DATA</b>  |  |                  |                |             |          | Total              |      |          |          | 1,106,200  | 1,106,200 |
| Alt Prcl ID   |  | Split Zonin      |                | Plan Ref.   |          |                    |      |          |          |  |           |
| #DL 1   |  | ResExpt Q        |                | Land Ct#    |          | 17994-K (SH 2)     |      |          |          |  |           |
| #DL 2   |  | YES:             |                | #SR         |          |                    |      |          |          |  |           |
| GIS ID  |  | F_985293_2719616 |                | Life Estate |          |                    |      |          |          |  |           |
|   |  |                  |                | PP STATU    |          |                    |      |          |          |  |           |
|   |  |                  |                | Assoc Pid#  |          |                    |      |          |          |  |           |

| RECORD OF OWNERSHIP            |         | BK-VOL/PAGE | SALE DATE  | Q/U | V/I | SALE PRIC | VC | PREVIOUS ASSESSMENTS (HISTORY) |      |          |       |      |          |
|--------------------------------|---------|-------------|------------|-----|-----|-----------|----|--------------------------------|------|----------|-------|------|----------|
| JONES, WARREN T & JEANNE R     | C162036 | 0           | 06-29-2001 | Q   | I   | 405,000   | 00 | Year                           | Code | Assessed | Year  | Code | Assessed |
| CROWLEY, MONIQUE M             | #D78780 | 0           | 12-20-1999 | U   | I   | 0         | 1  | 2023                           | 1010 | 475,500  | 2022  | 1010 | 416,400  |
| CROWLEY, WILLIAM J & MONIQUE M | C112788 | 0           | 11-15-1987 | Q   | I   | 255,000   | U  |                                | 1010 | 391,300  | 2021  | 1010 | 334,000  |
|                                |         |             |            |     |     |           |    | Total                          |      | 866,800  | Total |      | 750,400  |
|                                |         |             |            |     |     |           |    | Total                          |      |          | Total |      | 643,600  |

| EXEMPTIONS |      |                       |        | OTHER ASSESSMENTS |             |        |        | APPRAISED VALUE SUMMARY |   |  |  |  |
|------------|------|-----------------------|--------|-------------------|-------------|--------|--------|-------------------------|---|--|--|--|
| Year       | Code | Description           | Amount | Code              | Description | Number | Amount | Comm Int                | This signature acknowledges a visit by a Data Collector or Assessor |  |  |  |
| 2010       | 5C   | RESIDENTIAL EXEMPTION | 0.00   |                   |             |        |        |                         | Appraised Bldg. Value (Card) 475,400                                |  |  |  |
|            |      |                       | Total  |                   |             |        |        |                         | Appraised Xf (B) Value (Bldg) 66,000                                |  |  |  |
|            |      |                       |        |                   |             |        |        |                         | Appraised Ob (B) Value (Bldg) 9,700                                 |  |  |  |

| ASSESSING NEIGHBORHOOD |           | NOTES |         |
|------------------------|-----------|-------|---------|
| Nbhd                   | Nbhd Name | B     | Tracing |
| 0110                   |           |       | BARNS   |

| BUILDING PERMIT RECORD |            | VISIT / CHANGE HISTORY |                |         |            |        |            |                         |                              |    |      |    |           |                            |
|------------------------|------------|------------------------|----------------|---------|------------|--------|------------|-------------------------|------------------------------|----|------|----|-----------|----------------------------|
| Permit Id              | Issue Date | Type                   | Description    | Amount  | Insp Date  | % Comp | Date Comp  | Comments                | Date                         | Id | Type | Is | Cd        | Purpost/Result             |
| 201501131              | 03-12-2015 | PV                     | Solar PV Syste | 30,000  | 09-28-2015 | 100    | 06-30-2016 | INSTALL SOLAR PANELS ON | 05-11-2020                   | DM |      |    | FR        | Field Review               |
| 74105                  | 01-09-2004 | NW                     | New Windows    | 1,000   | 04-04-2005 | 100    | 01-01-2005 |                         | 02-29-2016                   | SR | 01   |    | 02        | Bldg Permit Completed      |
| 70104                  | 07-15-2003 | AD                     | Addition       | 100,000 | 04-04-2005 | 100    | 01-01-2005 |                         | 04-04-2005                   | MF | 02   |    | 02        | Bldg Permit Completed      |
|                        |            |                        |                |         |            |        |            |                         | 02-13-2004                   | MF | 02   |    | 13        | CALL BACK                  |
|                        |            |                        |                |         |            |        |            |                         | 08-25-2000                   | PT | 01   |    | 00        | Meas/Listed-Interior Acces |
|                        |            |                        |                |         |            |        |            |                         | 08-15-1994                   | ME | 02   |    | 01        | Meas/Est                   |
|                        |            |                        |                |         |            |        |            |                         | Total Appraised Parcel Value |    |      |    | 1,106,200 |                            |

| LAND LINE VALUATION SECTION |          |                |      |    |            |               |                        |         |            |       |       |           |                  |                    |            |            |
|-----------------------------|----------|----------------|------|----|------------|---------------|------------------------|---------|------------|-------|-------|-----------|------------------|--------------------|------------|------------|
| B                           | Use Code | Description    | Zone | LA | Land Units | Unit Price    | Size Adj               | AC Disc | Site Index | Cond. | Nbhd. | Nbhd. Adj | Notes            | Location Adjustmen | Adj Unit P | Land Value |
| 1                           | 1010     | Single Fam M-0 | RF-1 | 1  | 1.000      | AC 176,344.00 | 1.00000                | 1.0000  | 5          | 1.00  | 0110  | 3.100     |                  | 1.0000             | 546,666.4  | 546,700    |
| 1                           | 1010     | Single Fam M-0 | RF-1 | 1  | 0.190      | AC 14,250.00  | 1.00000                | 1.0000  | 0          | 1.00  | 0110  | 3.100     |                  | 1.0000             | 44,175     | 8,400      |
| Total Card Land Units       |          |                |      |    | 1.19       | AC            | Parcel Total Land Area |         |            |       |       | 1.19      | Total Land Value |                    |            | 555,100    |

| CONSTRUCTION DETAIL |    |                | CONSTRUCTION DETAIL (CONTINUED) |    |             |
|---------------------|----|----------------|---------------------------------|----|-------------|
| Element             | Cd | Description    | Element                         | Cd | Description |
| Style               | 01 | Ranch          |                                 |    |             |
| Model               | 01 | Residential    |                                 |    |             |
| Grade:              | C  | Average        |                                 |    |             |
| Stories             | 1  | 1 Story        |                                 |    |             |
| Exterior Wall 1     | 14 | Wood Shingle   |                                 |    |             |
| Exterior Wall 2     |    |                |                                 |    |             |
| Roof Structure      | 03 | Gable/Hip      |                                 |    |             |
| Roof Cover          | 03 | Asph/F Gls/Cmp |                                 |    |             |
| Interior Wall 1     | 05 | Drywall        |                                 |    |             |
| Interior Wall 2     |    |                |                                 |    |             |
| Interior Floor 1    | 14 | Carpet         |                                 |    |             |
| Interior Floor 2    | 12 | Hardwood       |                                 |    |             |
| Heat Fuel           | 02 | Oil            |                                 |    |             |
| Heat Type           | 04 | Hot Air        |                                 |    |             |
| AC Type             | 03 | Central        |                                 |    |             |
| Bedrooms            | 03 | 3 Bedrooms     |                                 |    |             |
| Full Baths          | 2  |                |                                 |    |             |
| Half Baths          | 0  |                |                                 |    |             |
| Extra Fixtures      |    |                |                                 |    |             |
| Total Rooms         | 7  | 7 Rooms        |                                 |    |             |
| Bath Style          |    |                |                                 |    |             |
| Kitchen Style       |    |                |                                 |    |             |
| Occupancy           |    |                |                                 |    |             |
| Usrflid 105         |    |                |                                 |    |             |
| Accessory Apt       |    |                |                                 |    |             |
| Foundation Alt      | 01 | Poured Conc.   |                                 |    |             |
| Rms Prts            |    |                |                                 |    |             |
| Bath Split          | 20 | 2 Full-0 Half  |                                 |    |             |

| CONDO DATA  |      |             |          |
|-------------|------|-------------|----------|
| Parcel Id   |      | C           | Owne 0.0 |
| Adjust Type | Code | Description | Factor%  |
| Condo Flr   |      |             |          |
| Condo Unit  |      |             |          |

| COST / MARKET VALUATION  |         |
|--------------------------|---------|
| Building Value New       | 572,751 |
| Year Built               | 1982    |
| Effective Year Built     | 1997    |
| Depreciation Code        | A       |
| Remodel Rating           |         |
| Year Remodeled           |         |
| Depreciation %           | 17      |
| Functional Obsol         | 0       |
| External Obsol           | 0       |
| Trend Factor             | 1       |
| Condition                |         |
| Condition %              |         |
| Percent Good             | 83      |
| RCNLD                    | 475,400 |
| Dep % Ovr                |         |
| Dep Ovr Comment          |         |
| Misc Imp Ovr             |         |
| Misc Imp Ovr Comment     |         |
| Cost to Cure Ovr         |         |
| Cost to Cure Ovr Comment |         |

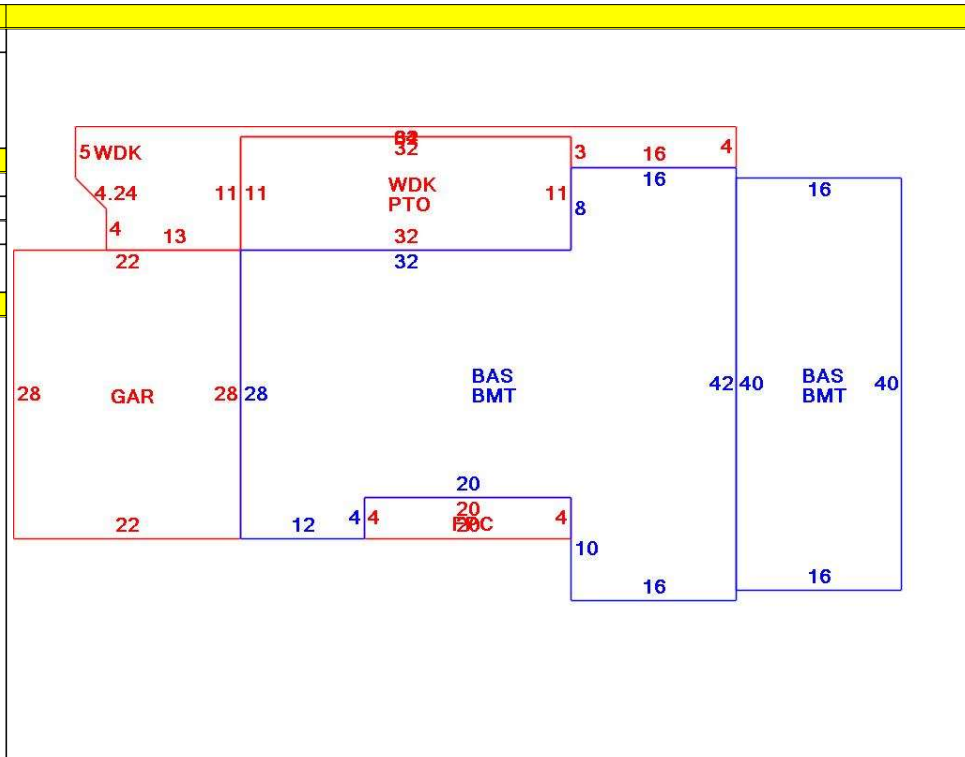

| OB - OUTBUILDING & YARD ITEMS(L) / XF - BUILDING EXTRA FEATURES(B) |                 |     |       |            |        |          |      |       |            |             |
|--|-----------------|-----|-------|------------|--------|----------|------|-------|------------|-------------|
| Code   | Description     | L/B | Units | Unit Price | Yr Blt | Cond. Cd | % Gd | Grade | Grade Adj. | Appr. Value |
| FPL1   | Fireplace 1 sto | B   | 1     | 5000.00    | 1999   |          | 83   |       | 0.00       | 4,200       |
| FPO  | Ext FP Openin   | B   | 1     | 2000.00    | 1999   |          | 83   |       | 0.00       | 1,700       |
| WDC  | Wood Decking    | L   | 624   | 20.00      | 2004   |          | 70   |       | 0.00       | 8,100       |
| FOPC   | Open Prch-roo   | B   | 80    | 55.00      | 1999   |          | 83   |       | 0.00       | 3,300       |
| GAR  | Attached Gara   | B   | 616   | 40.00      | 1999   |          | 83   |       | 0.00       | 17,800      |
| BMT  | Basement-Unfi   | B   | 2,128 | 26.01      | 1999   |          | 83   |       | 0.00       | 39,000      |
| PAT1   | Patio- Average  | L   | 352   | 5.89       | 1996   |          | 77   |       | 0.00       | 1,600       |
| SOL2   | Solar PV Pane   | B   | 45    | 725.00     | 1999   |          | 0    |       | 0.00       | 0           |

| BUILDING SUB-AREA SUMMARY SECTION |                        |             |            |          |           |                |
|-----------------------------------|------------------------|-------------|------------|----------|-----------|----------------|
| Code                              | Description            | Living Area | Floor Area | Eff Area | Unit Cost | Undeprec Value |
| BAS                               | First Floor            | 2,128       | 2,128      | 2,128    | 269.15    | 572,751        |
| BMT                               | Basement Area          | 0           | 2,128      | 0        | 0.00      | 0              |
| FPC                               | Open Porch Conc. Floor | 0           | 80         | 0        | 0.00      | 0              |
| GAR                               | Attached Garage        | 0           | 616        | 0        | 0.00      | 0              |
| PTO                               | Patio                  | 0           | 352        | 0        | 0.00      | 0              |
| WDK                               | Wood Deck              | 0           | 624        | 0        | 0.00      | 0              |
| Ttl Gross Liv / Lease Area        |                        | 2,128       | 5,928      | 2,128    |           | 572,751        |

