

| CURRENT OWNER | | | TOPO | UTILITIES | STRT / ROAD | LOCATION | CURRENT ASSESSMENT | | | | |
|------------------------------|--|--|------|-----------|-------------|--------------|---------------------------|------|-----------|-----------|---------------------------------|
| COSTA, ALBERTO & CHRISTINE L | | | | | | 1 Excel View | Description | Code | Assessed | Assessed | 801 FY2024 BARNSTABLE, MA |
| 15 WHISPERING LANE | | | | | | | RESIDNTL | 1010 | 806,400 | 806,400 | |
| | | | | | | | RES LAND | 1010 | 1,759,900 | 1,759,900 | |
| HOLLISTON MA 01746 | | | | | | | Total 2,566,300 2,566,300 | | | | |

| SUPPLEMENTAL DATA | |
|-------------------------|------------------|
| Alt Prcl ID | Plan Ref. |
| Split Zonin | Land Ct# 17933-H |
| BID Parcel | #SR |
| ResExpt Q | Life Estate |
| #DL 1 LOT 196 | PP STATU |
| #DL 2 | |
| GIS ID F_984755_2721376 | Assoc Pid# |

VISION

| RECORD OF OWNERSHIP | | BK-VOL/PAGE | SALE DATE | Q/U | V/I | SALE PRIC | VC | PREVIOUS ASSESSMENTS (HISTORY) | | | | | | | | |
|------------------------------|---------|-------------|------------|-----|-----|-----------|----|--------------------------------|------|-----------|-------|------|-----------|-------|------|-----------|
| COSTA, ALBERTO & CHRISTINE L | C195617 | 0 | 11-09-2011 | Q | I | 1,572,500 | 00 | Year | Code | Assessed | Year | Code | Assessed | Year | Code | Assessed |
| PIGOTT, PRUDENCE | C187163 | 0 | 10-17-2008 | U | I | 910,000 | 1 | 2023 | 1010 | 623,700 | 2022 | 1010 | 573,000 | 2021 | 1010 | 488,100 |
| FLETCHER, JEROME H TR | C151224 | 0 | 12-11-1998 | U | I | 1 | 1A | | 1010 | 2,266,600 | | 1010 | 1,160,500 | | 1010 | 1,160,500 |
| PEARSON, DOROTHY M | 84P2049 | 0 | 04-18-1986 | U | I | 0 | 1 | | | | | | | | 1010 | 5,800 |
| PEARSON, MAXWELL J & DOROTHY | C59543 | 0 | 08-06-1973 | U | | 0 | | Total | | 2,890,300 | Total | | 1,733,500 | Total | | 1,654,400 |

| EXEMPTIONS | | | OTHER ASSESSMENTS | | | | | |
|------------|------|-------------|-------------------|------|-------------|--------|--------|----------|
| Year | Code | Description | Amount | Code | Description | Number | Amount | Comm Int |
| | | | | | | | | |
| Total | | | 0.00 | | | | | |

This signature acknowledges a visit by a Data Collector or Assessor

| ASSESSING NEIGHBORHOOD | | | |
|------------------------|-----------|---|---------|
| Nbhd | Nbhd Name | B | Tracing |
| 0118 | | | BARNS |

| APPRAISED VALUE SUMMARY | |
|-------------------------------|-----------|
| Appraised Bldg. Value (Card) | 751,200 |
| Appraised Xf (B) Value (Bldg) | 43,800 |
| Appraised Ob (B) Value (Bldg) | 11,400 |
| Appraised Land Value (Bldg) | 1,759,900 |
| Special Land Value | 0 |
| Total Appraised Parcel Value | 2,566,300 |
| Valuation Method | C |
| Total Appraised Parcel Value | 2,566,300 |

| NOTES | | | | | | | | |
|-------|--|--|--|--|--|--|--|--|
| | | | | | | | | |

| BUILDING PERMIT RECORD | | | | | | | | | VISIT / CHANGE HISTORY | | | | | |
|------------------------|------------|------|----------------|---------|------------|--------|------------|-----------------------------|------------------------|----|------|----|----|-----------------------|
| Permit Id | Issue Date | Type | Description | Amount | Insp Date | % Comp | Date Comp | Comments | Date | Id | Type | Is | Cd | Purpost/Result |
| EXPR-21-3 | 03-26-2021 | 835 | Sid/Wind/Roof/ | 135,000 | 06-30-2022 | 100 | 06-30-2022 | Replace windows with Anders | 02-06-2023 | DB | 02 | | 03 | Cycl Insp Comp |
| 200904566 | 10-15-2009 | DW | Dwelling | 369,000 | 06-19-2010 | 100 | 06-30-2010 | 3 BDRM 2.5BTH W ATT GAR | 05-05-2020 | DM | | | FR | Field Review |
| 200904564 | 09-25-2009 | DE | Demolish | 9,000 | 06-19-2010 | 100 | 06-30-2010 | EXIST DW | 08-26-2016 | SR | 02 | | 03 | Cycl Insp Comp |
| | | | | | | | | | 02-01-2012 | JR | 03 | | 20 | Sale Review |
| | | | | | | | | | 11-21-2011 | NF | 02 | | 20 | Sale Review |
| | | | | | | | | | 07-12-2010 | NF | 03 | | 02 | Bldg Permit Completed |
| | | | | | | | | | 07-09-2009 | NF | 03 | | 16 | In Office Review |

| LAND LINE VALUATION SECTION | | | | | | | | | | | | | | | | | |
|-----------------------------|----------|----------------|------|----|------------|------------|------------------------|---------|------------|-------|-------|-----------|------------------|-------------------------|------------|------------|-----------|
| B | Use Code | Description | Zone | LA | Land Units | Unit Price | Size Adj | AC Disc | Site Index | Cond. | Nbhd. | Nbhd. Adj | Notes | Location Adjustmen | Adj Unit P | Land Value | |
| 1 | 1010 | Single Fam M-0 | RB | 1 | 0.230 | AC | 176,344.00 | 3.61599 | 1.0000 | 5 | 1.00 | 0119 | 12.000 | WF-SEE CTF 195617-PRIVA | 1.0000 | 7,651,901 | 1,759,900 |
| Total Card Land Units | | | | | 0.23 | AC | Parcel Total Land Area | | | | | 0.23 | Total Land Value | | | 1,759,900 | |

| CONSTRUCTION DETAIL | | | CONSTRUCTION DETAIL (CONTINUED) | | |
|---------------------|----|----------------|--------------------------------------|----|-------------|
| Element | Cd | Description | Element | Cd | Description |
| Style | 07 | Modern/Contemp | | | |
| Model | 01 | Residential | | | |
| Grade: | A | Luxury | | | |
| Stories | 2 | 2 Stories | | | |
| Exterior Wall 1 | 14 | Wood Shingle | | | |
| Exterior Wall 2 | | | | | |
| RooF Structure | 03 | Gable/Hip | | | |
| RooF Cover | 03 | Asph/F Gls/Cmp | | | |
| Interior Wall 1 | 05 | Drywall | | | |
| Interior Wall 2 | | | | | |
| Interior Floor 1 | 12 | Hardwood | | | |
| Interior Floor 2 | | | | | |
| Heat Fuel | 03 | Gas | | | |
| Heat Type | 04 | Hot Air | | | |
| AC Type | 03 | Central | | | |
| Bedrooms | 03 | 3 Bedrooms | | | |
| Full Baths | 2 | | | | |
| Half Baths | 1 | | | | |
| Extra Fixtures | | | | | |
| Total Rooms | 5 | | | | |
| Bath Style | | | | | |
| Kitchen Style | | | | | |
| Occupancy | | | | | |
| Usrflid 105 | | | | | |
| Accessory Apt | | | | | |
| Foundation Alt | 01 | Poured Conc. | | | |
| Rms Prts | | | | | |
| Bath Split | 21 | 2 Full-1 Half | | | |
| | | | CONDO DATA | | |
| | | | Parcel Id | C | Owne 0.0 |
| | | | Adjust Type Code Description Factor% | | |
| | | | Condo Flr | | |
| | | | Condo Unit | | |
| | | | COST / MARKET VALUATION | | |
| | | | Building Value New | | 807,729 |
| | | | Year Built | | 2009 |
| | | | Effective Year Built | | 2010 |
| | | | Depreciation Code | | A |
| | | | Remodel Rating | | |
| | | | Year Remodeled | | |
| | | | Depreciation % | | 7 |
| | | | Functional Obsol | | 0 |
| | | | External Obsol | | 0 |
| | | | Trend Factor | | 1 |
| | | | Condition | | |
| | | | Condition % | | |
| | | | Percent Good | | 93 |
| | | | RCNLD | | 751,200 |
| | | | Dep % Ovr | | |
| | | | Dep Ovr Comment | | |
| | | | Misc Imp Ovr | | |
| | | | Misc Imp Ovr Comment | | |
| | | | Cost to Cure Ovr | | |
| | | | Cost to Cure Ovr Comment | | |

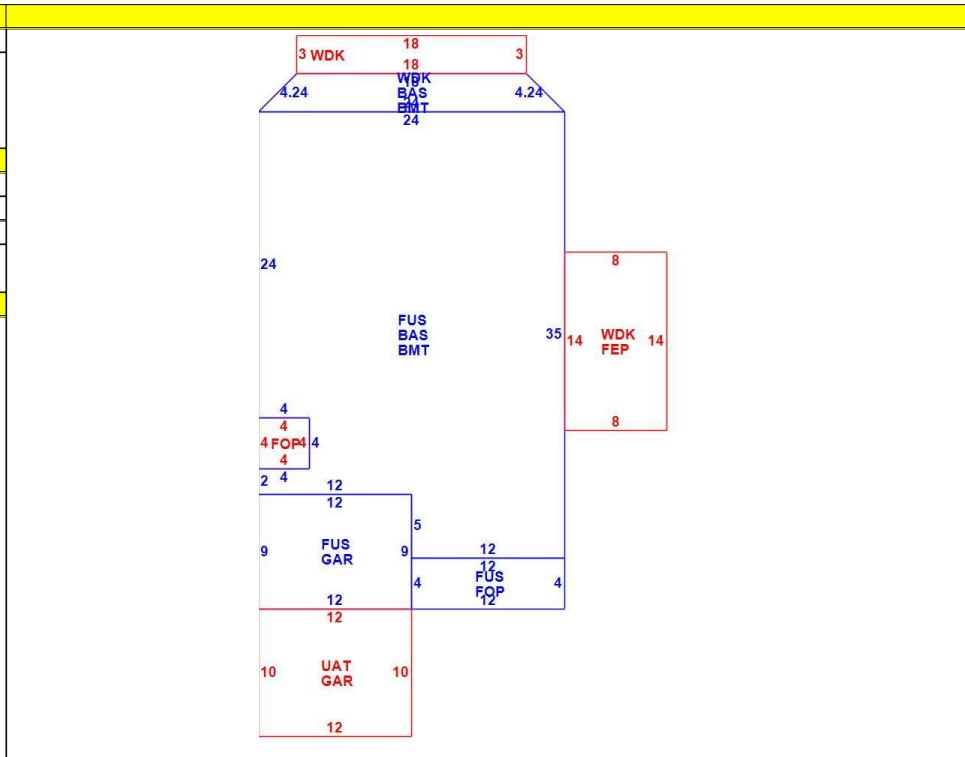

| OB - OUTBUILDING & YARD ITEMS(L) / XF - BUILDING EXTRA FEATURES(B) | | | | | | | | | | |
|--|---------------|-----|-------|------------|--------|----------|------|-------|------------|-------------|
| Code | Description | L/B | Units | Unit Price | Yr Blt | Cond. Cd | % Gd | Grade | Grade Adj. | Appr. Value |
| WDC | Wood Decking | L | 175 | 20.00 | 2010 | | 82 | | 0.00 | 3,600 |
| FOP | Open Porch-ro | B | 64 | 55.00 | 2012 | | 93 | | 0.00 | 3,800 |
| GAR | Attached Gara | B | 228 | 40.00 | 2012 | | 93 | | 0.00 | 10,100 |
| BMT | Basement-Unfi | B | 827 | 26.01 | 2012 | | 93 | | 0.00 | 21,600 |
| WDC | Wood Deck w/ | L | 54 | 18.00 | 2010 | | 82 | | 0.00 | 2,200 |
| FEP | Enclosed porc | B | 112 | 70.00 | 2012 | | 93 | | 0.00 | 8,300 |
| GEN | Emergency Ge | L | 1 | 5550.00 | 2022 | | 100 | | 0.00 | 5,600 |

| BUILDING SUB-AREA SUMMARY SECTION | | | | | | | |
|-----------------------------------|-------------------|-------------|------------|----------|-----------|----------------|--|
| Code | Description | Living Area | Floor Area | Eff Area | Unit Cost | Undeprec Value | |
| BAS | First Floor | 827 | 827 | 827 | 459.20 | 379,757 | |
| BMT | Basement Area | 0 | 827 | 0 | 0.00 | 0 | |
| FEP | Enclosed Porch | 0 | 112 | 0 | 0.00 | 0 | |
| FOP | Open Porch | 0 | 64 | 0 | 0.00 | 0 | |
| FUS | Upper Story | 920 | 920 | 920 | 459.20 | 422,462 | |
| GAR | Attached Garage | 0 | 228 | 0 | 0.00 | 0 | |
| UAT | Attic, Unfinished | 0 | 120 | 12 | 45.92 | 5,510 | |
| WDK | Wood Deck | 0 | 229 | 0 | 0.00 | 0 | |
| Ttl Gross Liv / Lease Area | | 1,747 | 3,327 | 1,759 | | 807,729 | |

